

# **Subject and object marking in Bembe**

David Edy Iorio

B.A. Ruhr-Universität Bochum, Germany (2008)

M.A. Newcastle University (2009)

Thesis submitted in partial fulfilment of the  
requirements for the degree of  
Doctor of Philosophy

at

the University of Newcastle upon Tyne  
School of English Literature,  
Language and Linguistics

February 2015

## **Abstract**

Two notable typological characteristics of the Bantu languages are the phenomena of subject and object marking, the cross-referencing of co-referential arguments via verbal morphology. The cross-linguistic variation with respect to the distributional and interpretational properties of Bantu subject and object markers has led to a dichotomy of their roles between being either agreement morphology or (incorporated) pronouns. Despite an increasing number of explanatory attempts of these phenomena, a unifying formal derivation of this inter- and intra-language variation is yet to be found. This thesis is an attempt towards providing a solution by giving a grammatical description of the under-documented Bantu language Bembe (D54) and presenting a novel analysis that employs an Agree-based approach while still accounting for the pronominal properties of Bembe subject and object markers.

Subject and object markers in Bembe cannot co-occur with the arguments they cross-reference, unless the latter are dislocated. In addition, subject marking only occurs with preverbal subjects (A'-position) but not with postverbal subjects (A-position). I demonstrate that these and a number of other facts are explained under the assumption that both subject and object markers in Bembe are pronominal elements rather than agreement morphology. In particular, I treat subject and object markers as defective clitics ( $\phi$ Ps), which incorporate into their probe whenever their  $\phi$ -feature set is a subset of the  $\phi$ -feature set of the probe. Incorporation is seen as Agree-based phenomenon (Roberts 2010a,b), necessary to satisfy the feature-valuation requirements of heads.

Besides capturing the subject and object marking facts in Bembe, the presented analysis is able to give a principled explanation as to (a) the difference in interpretation of preverbal and postverbal elements, (b) the constraint on locative constructions and default agreement inversions to appear only with unaccusative and copular verbs, (c) the ungrammaticality of subject-object reversals, and (d) the variation in subject marking in object relative clauses.

## **Declaration**

No part of the material contained within this thesis has previously been submitted for a degree at Newcastle University or any other university.

## **Statement of Copyright**

The copyright of this thesis rests with the author. No quotation should be published from it without his prior written consent and information derived from it should be acknowledged.

*Odi et amo. Quare id faciam, fortasse requiris?  
Nescio, sed fieri sentio et excrucior.* (Catullus 85)

## **Acknowledgements**

I am most grateful and indebted to Prof Anders Holmberg and Dr Jenneke van der Wal for their supervision of this research. Their patience in debating research methodology, reading numerous unfinished drafts, discussing half-baked ideas, and providing constructive feedback on virtually every aspect of this thesis has been invaluable throughout my journey. I am especially thankful for their constant attempts of motivating me, often at times of near despair, without which I would probably not have finished. I am also much obliged to the School of English Literature, Language and Linguistics at Newcastle University, which awarded me a doctoral studentship funded from the AHRC Block Grant Partnership (AH/J500306/1), without which this thesis would not have been possible.

I also thank Georges Kisombola and Iddi Mulengwa, through whose help I was able to find my first language informant Eky Esenga. It was the latter who made it possible for me to establish contact with a large part of the Bembe community in the UK and, to gather together with his wife Yvonne Asha Babilye Esenga and Yassin Toyé the necessary language data. I extend my gratitude to Pierre Mmunga Mulengwa (Mas1), Charles Asukulu Mulengwa (Mas2), Jean-Claude Mulanga and Asukulu Ilelwa Etoke for their patience in conducting countless interviews over the phone.

I express my gratitude to the colleagues and fellow researchers I have met over the course of four years and which helped a great deal along the way. Ali Algryani, Malgorzata Krzek and Ana Luiza Araújo Lopes, I wish I could have been more often in Newcastle and Cambridge. I also thank Prof Maggie Tallerman, Dr Joel Wallenberg and Geoffrey Poole. Parts of the research in this thesis have been presented at the Postgraduate Conference in Linguistics at Newcastle University, the Fifth International Conference on Bantu languages in Paris in the spring of 2013 and at Cambridge University in 2014. I extend my gratitude to the audiences for their interest, insightful comments and discussions.

Lastly, I want to thank my family and friends who have always encouraged and supported me. Mamma e papà, grazie di cuore! Tutto questo sarebbe stato impossibile senza di voi.

## Table of Contents

Abstract.....	i
Declaration.....	ii
Statement of Copyright.....	ii
Acknowledgements.....	iv
List of Tables.....	viii
List of Figures.....	viii
List of abbreviations and symbols.....	ix
<b>Chapter 1 - Introduction .....</b>	<b>1</b>
1.1 Aim of the thesis.....	1
1.2 Bembe.....	6
1.2.1 Basic facts about the language and its speakers.....	6
1.2.2 The data.....	9
1.3 Theoretical background.....	11
1.4. Outline of the thesis.....	18
<b>Chapter 2 – A grammatical description of Bembe.....</b>	<b>20</b>
2.1 Phonetics.....	20
2.1.1 Vowels.....	20
2.1.2 Semi-vowels.....	23
2.1.3 Consonants.....	24
2.1.4 Syllable structure.....	27
2.2 Nouns and nominal categories.....	28
2.2.1 Nouns and the noun class system.....	28
2.2.2 Personal pronouns.....	47
2.2.3 Reflexive pronouns.....	49
2.2.4 Possessive pronouns.....	50
2.2.5 Possessive connective construction.....	51
2.2.6 Demonstratives.....	54
2.2.7 Coordinator.....	57
2.2.8 Noun modification.....	60
2.2.9 Numerals.....	68
2.2.10 Quantifiers.....	70
2.2.11 Prepositions.....	77
2.2.12 Interrogative pronouns.....	84
2.2.13 Conjunctions.....	85

2.2.14	Word order in the nominal phrase .....	91
2.3	Verbs and verbal categories .....	94
2.3.1	The structure of the Bembe verb .....	94
2.3.2	Verbal categories .....	95
2.3.2.1	Pre-initial position.....	96
2.3.2.2	Initial position .....	100
2.3.2.3	Post-initial position .....	102
2.3.2.4	TAM position.....	103
2.3.2.5	Pre-radical position .....	105
2.3.2.6	Radical position .....	111
2.3.2.7	Post-radical position.....	112
2.3.2.8	Final position .....	126
2.3.3	The tense/aspect/mood (TAM) system.....	127
2.3.3.1	Affirmative conjugations .....	127
2.3.3.2	Non-affirmative conjugations .....	138
2.3.4	Adverbs.....	148
2.4	The syntax of clauses .....	152
2.4.1	Simple declarative clauses .....	152
2.4.2	Relative clauses .....	154
2.4.3	Cleft sentences .....	161
2.4.4	Conditional clauses.....	166
2.4.5	Interrogative clauses .....	167
<b>Chapter 3</b>	<b>- Object marking in Bembe .....</b>	<b>181</b>
3.1	Introduction.....	181
3.1.1	General properties of Bantu object marking.....	181
3.1.2	Overview of the chapter.....	184
3.2	Agreement markers vs. incorporated pronoun.....	186
3.2.1	Diagnostics to distinguish agreement from incorporation.....	186
3.2.2	Discussion.....	191
3.3	A pronominal analysis of Bembe object markers.....	195
3.3.1	General properties.....	195
3.3.2	Differential object marking.....	198
3.3.3	Evidence in favour of pronominal object-marking in Bembe .....	206
3.3.4	Summary.....	214
3.4	The syntactic status of object markers in Bembe .....	214
3.5	The structural representation of object markers in Bembe .....	218

3.5.1	The verb in Bantu .....	218
3.5.2	Clitic-movement approaches .....	223
3.6	Summary and conclusions .....	258
<b>Chapter 4</b>	<b>– Subject marking in Bembe .....</b>	<b>261</b>
4.1	Introduction.....	261
4.2	The categorial status of subject markers.....	264
4.2.1	Subject markers as ambiguous elements .....	265
4.2.2	Agreement morphology or pronouns? .....	268
4.2.3	The categorial status of the subject marker .....	275
4.3	The structural representation of subject markers.....	277
4.3.1	Relative clauses – Theoretical background .....	278
4.3.2	Bresnan & Mchombo (1987).....	283
4.3.3	Baker (2003, 2008) .....	286
4.3.4	Carstens (2005).....	298
4.3.5	Henderson (2006, 2011a).....	302
4.3.6	A proposal.....	315
4.4	Circumstances alter cases .....	338
4.5	Summary and conclusions .....	348
<b>Chapter 5</b>	<b>- Conclusions.....</b>	<b>352</b>
5.1	Subject/object marking and word order.....	352
5.2	Questions for further research.....	357
	References.....	361



## List of Tables

Table 1: BEMBE VOWEL INVENTORY.....	20
Table 2: BEMBE CONSONANT INVENTORY.....	24
Table 3: BEMBE SYLLABIC STRUCTURE.....	28
Table 4: NOUN CLASSES IN BEMBE.....	30
Table 5: NOUN-CLASS PAIRINGS.....	36
Table 6: PERSONAL PRONOUNS.....	47
Table 7: PERSONAL PRONOUNS (classes 3-19).....	48
Table 8: POSSESSIVE PREFIXES.....	51
Table 9: POSSESSIVE ROOTS.....	51
Table 10: CONNECTIVE MARKERS (POSSESSIVE MODIFICATION).....	53
Table 11: DEMONSTRATIVES.....	55
Table 12: CONNECTIVE MARKERS (NOMINAL MODIFICATION).....	62
Table 13: CARDINAL NUMBERS.....	70
Table 14: QUANTIFICATIONAL PREFIXES.....	71
Table 15: AGREEING PREFIXES IN THE NOMINAL DOMAIN.....	77
Table 16: EXPRESSION OF SPATIAL CONCEPTS.....	84
Table 17: CONJUNCTIONS.....	91
Table 18: THE STRUCTURE OF THE BEMBE VERB.....	94
Table 19: BEMBE VERBAL SLOTS.....	95
Table 20: RELATIVE MARKERS.....	97
Table 21: BEMBE SUBJECT MARKERS.....	101
Table 22: TAM MARKERS AND CONJUGATIONS.....	104
Table 23: BEMBE OBJECT MARKERS.....	108
Table 24: AGREEING PREFIXES IN THE VERBAL DOMAIN.....	111
Table 25: SYLLABIC FORM OF BEMBE VERB ROOTS.....	112
Table 26: THE BEMBE TENSE & ASPECT SYSTEM.....	148
Table 27: MANNER ADVERBS RESULTING FROM REDUPLICATION.....	149
Table 28: LOCATIVE ADVERBS.....	150
Table 29: ORDERING OF OBJECT ARGUMENTS.....	153
Table 30: SUMMARY OF PLACEMENT FACTS FOR <i>beni</i> ‘who’.....	170
Table 31: SUMMARY OF PLACEMENT FACTS FOR <i>éé</i> ‘what’.....	174
Table 32: BEMBE WH-WORDS AND THEIR SENTENTIAL DISTRIBUTION.....	180
Table 33: PROPERTIES OF BEMBE OBJECT MARKERS.....	217
Table 34: ARGUMENTS IN FAVOUR OF ABSENT <i>UCASE</i> FEATURES IN BEMBE.....	348

## List of Figures

Fig. 1: GEOGRAPHICAL MAP OF BEMBE EXTENSION.....	8
FIG. 2: COGNITIVE SYSTEM OF THE LANGUAGE FACULTY.....	12
Fig. 3: LOCATIVE NOUN FORMATION.....	35
Fig. 4: FORMATION OF CONNECTIVE MARKERS.....	52
Fig. 5: NOMINAL MODIFICATION WITH CONNECTIVES.....	61

## List of abbreviations and symbols

'	high tone	ING	gerund
`	low tone	IO	Indirect object
[ ]	phonetic representation	IP	Inflectional Phrase
/	or	LOC	locative
//	phonological representation	MOD	modal
	pause	<sup>n</sup>	pre-nasalised
>	precede(s)	N	nasal
<>	either precedes or follows	NEG	negation
*	ungrammatical	NegP	Negation Phrase
??	reduced ungrammaticality	NOM	nominative case
#	infelicitous	N.PST	near past
ACC	accusative case	OM	object marker
adv	adverb	PASS	passive
AO	Applied object	PERS	personal pronoun
APPL	applicative	PL	plural
Asp	aspect	POSS	possessive
AspP	Aspect Phrase	POT	potential
C	consonant	PRES	present
CAUS	causative	PST	past tense
cl.	class	REC	reciprocal
COMP	complementiser agreement	RED	reduplication
CONN	connective	REF	reflexive
COP	copula	REL	relative
CP	Complementiser Phrase	REL	relative marker
D	determiner	REV	reversive
DAT	dative case	S	semi-vowel
DEM.dist	distal demonstrative	sb.	somebody
DEM.med	medial demonstrative	S.FUT	successive future
DEM.prox	proximal demonstrative	SG	singular
DO	Direct object	SM	subject marker
DP	Determiner Phrase	STAT	Stative
DUR	durative	s.th.	something
Eng.	English	Sw.	Swahili
EXPL	expletive	T	tense
FOC	focus	T	Tense
FocP	Focus Phrase	TP	Tense Phrase
F.PST	far past	TAM	tense, aspect, mood
FUT	future	TOP	topic
FV	final vowel	V	1. Verb; 2. Vowel
HAB	habitual	VB	verbal base
I	Inflection	VP/vP	Verb Phrase
IMP	imperative	X	Adjunct/oblique
INF	infinitive	Ø	zero morpheme

## CHAPTER 1 - INTRODUCTION

### 1.1 Aim of the thesis

Everybody would probably agree with the statement that the accurate description of a language does not merely serve linguaphile interests but is also an indispensable means for testing and advancing linguistic theory. The immense number of languages one finds in the Bantu language continuum – estimates vary from 440 to 680 (Nurse & Philippson 2003: 2) – and the variation that exist between them despite their similarities offer a fertile testing ground for linguistic theory. However, a large number of the Bantu languages remain under- or undocumented. The state-of-affairs with respect to the impact Bantu, and African languages in general, has had so far in the theoretical branch of linguistics, and in particular syntactic theory, is even more lamentable. A quarter of a century ago, Bresnan (1990: 35) already noted that “research has not had the same revolutionary impact upon syntax that Africanist research has had on phonology, where a fundamental restructuring of phonological theory was brought about.” More recent statements echo the same concerns. Bearth (2003: 121) points out that “[m]ost published descriptions of Bantu languages concentrate on lexical and morphological structure. Studies explicitly dealing with syntactic phenomena are rare and are unevenly distributed over the area”, and with respect to word order, he notes that the “[v]ariability of verb-external constituent order is a widespread although insufficiently studied phenomenon of Bantu syntax.” (Bearth 2003: 128). In their introduction to *The Bantu-Romance Connection*, De Cat & Demuth (2008: xi) criticise that “the study of Bantu languages, especially from a more theoretical perspective, has received much less attention” [than Romance linguistic structures; DI]. Henderson (2011b: 15) concedes that the number of researchers working within Bantu is steadily growing but his assessment, namely that in most cases the analysed phenomena “are taken to be peripheral to the core understanding of syntax”, shows that much work remains to be done.

This thesis is a direct response to the call for more theoretically informed research expressed in this brief assessment on the state of descriptive and syntactic research on Bantu languages in the form of a grammatical description of the under-documented Bantu-language Bembe and a syntactic account of verb marking and its theoretical implications. At the core of this analysis lie the phenomena of subject and object

marking, and, in particular, the proposal of a novel analysis that employs an Agree-based approach while still accounting for the pronominal properties of subject and object markers.

One of the most noticeable typological characteristics of Bantu languages is the cross-referencing of co-referential arguments via subject and object markers on the verb. Typically, preverbal subjects trigger obligatory subject agreement on the verb in a SVO word order, which is taken to be the unmarked word order in Bantu languages. This is exemplified by the Bembe example in (1).

- (1) *Bawambaka* *ba-som-ile* *bitabo.* S V O  
 2boy 2SM-read-PST 7book  
 “The boys read a book.”

Furthermore, Bantu languages also show a great deal of flexibility in word order, and a part of the appeal exhibited by Bantu languages stems from their at times radical difference to constructions in more well-studied Indo-European languages. Oft-cited examples include what is commonly referred to as subject-object reversals and locative inversions, as in the examples in (2), respectively.

- (2) a. *Igitabo* *ki-som-a* *umuhuungu.* O V S  
 7book 7-read-ASP 1boy  
 “THE BOY is reading the book.” (Kinyarwanda; Morimoto 2002 :163)
- b. *Mò-ngàndá* *mw-á-hítí* *òvá-ndù.* LOC V S  
 18-9house 18-PST-enter 2-people  
 “Into the house entered (the) guests.” (Herero; Marten 2006: 98)

In subject-object reversals (2a), a patient object DP appears in preverbal position and determines subject marking on the verb, while a logical subject DP appears postverbally and is presentationally focused. In locative inversions (2b), a locative DP induces subject marking on the verb, while the logical subject DP appears in postverbal position. While these constructions are pervasive throughout the Bantu languages (Marten & van der Wal, Forthcoming), not every Bantu language displays all of these constructions. In fact, what also makes the study of Bantu languages interesting is the fact that the language family, although showing many similarities, is characterised by a

great deal of micro-variation in subject and object-marking patterns. This becomes particularly important from a comparative perspective when pursuing the question as to whether the syntactic structures underlying the surface similarities between languages are identical or not. This flexibility in word order, and more importantly subject and object marking patterns seriously challenge central aspects of current syntactic theory.

While Bembe does not feature subject-object reversals (OVS word orders) locative inversion is allowed. The latter construction is restricted to unaccusative and copular verbs, a restriction which is shared by some but not given in all Bantu languages. Two questions that arise are why subject-object reversals are ungrammatical in Bembe and why locative constructions and default agreement inversions, albeit grammatical, can only appear with unaccusative and copular verbs. Particularly revealing in this respect is the variation that Bembe shows with respect to object relative clauses. Bembe relative clauses in general display agreement with the relativised element. In what I will refer to as Type 1 object relative clauses (3), the verb shows relative agreement with the relativised object DP and subject agreement with a covert subject while a cross-referential subject DP is prohibited.

- (3) *bilewa bya-ba-koch-ilé* ( *\*baana*) [Type 1 object relative]  
 8food 8REL-2SM-buy-PST 2child  
 “the food that they bought”

Type 2 object relative clauses (4), in turn, show agreement with the relativised object only and must display a postverbal subject DP while subject marking is ungrammatical.

- (4) *bilewa bya-koch-ilé baana* [Type 2 object relative]  
 8food 8REL-buy-PST 2child  
 “the food that (some) children bought”

Furthermore, the subject in Type 1 object relatives is necessarily interpreted as discourse-old information, whereas it is interpreted as new information in Type 2 object relatives.

Covert subjects are expressed by a subject marker on the verb while overt subjects must appear postverbally without subject marking. That this variation in object relatives is not restricted to Bembe, is illustrated by the examples in (5) taken from Kilega (D25),

a neighbouring language. Another language that demonstrates this variation is Chiluba (L31), also spoken in the DRC.

- (5) a. *Mukíngú u-mu-ku-áák-il-á nyumba á-ku-bogabog-a.*  
 1old person 1RM-IIPL-PROG-erect-APPL-FV 9house 1AGR-FUT-be.happy-FV  
 “The old person for whom you are building a house will be happy.”
- b. *Bitondo bí-ku-ténd-a úzo mwána ta-bí-lí bi-soga.*  
 8word 8RM-PROG-say-FV 1that 1child NEG-8SA-be 8AGR-good  
 “The words which the child is saying are not good.”

(Kilega; Kinyalolo 1991: 23)

What makes these two object relative constructions interesting from a syntactic point of view is the fact that current syntactic theories struggle to account for the variation vis-à-vis subject marking, as they are unable to explain why subject DPs can remain postverbal, yielding Type 2 object relatives, while pronominal subjects (presumably null given the subject marking on the verb) can raise into a preverbal position, yielding Type 1 object relatives. The reason for this, as I claim, lies in the uniform treatment of subject markers as agreement morphology. Current minimalist proposals reduce the presence of subject marking in Bembe Type 1 relatives to the spell-out of an Agree relation between the functional head T and a standardly assumed null subject *pro*. Under this assumption, however, one is forced either to resort to drastic changes to the process of the feature-valuation operation *Agree* (Baker 2003, 2008; Carstens 2005; Collins 2004; Henderson 2006) and/or to assume arbitrariness in the form of optionality with respect to the underlying structure (Henderson 2011a) in order to explain why verbs in Bembe are only marked by (arguably) a preverbal null subject *pro* but not a postverbal subject DP (Type 1 vs. Type 2 object relatives). This difference in sentential distribution between *pro* and subject DPs in Bembe also contradicts claims about the validity of the E(xtended) P(rojection) P(rinciple) (Chomsky 1981) for Bembe and about its alleged universal nature.

I believe that the variation in Bembe object relative clauses and, crucially, in Bembe subject marking is better explained under a theory that assumes that subject markers are pronominal elements rather than simple agreement morphology. I treat them as featurally defective clitics, more precisely  $\phi$ Ps (in the sense of Roberts 2010a,b; Holmberg 2010).  $\phi$ Ps act as goals and when the feature sets of  $\phi$ Ps are a proper subset of the features of a functional probe, they incorporate into the probe as a result.

Incorporation is thus treated as a corollary of the operation Agree, and precludes the need for a spec,TP position, which explains the A'-properties of preverbal subject DPs in Bembe and derives the variation in object relative clauses. If we additionally assume that an Agree relation between a functional probe and a DP goal is not spelled out and that some version of Kinyalolo's (1991) constraint holds in Bembe, the proposed account enables us to derive the variation in object relative clauses, and a number of different subject-marking patterns and word-order possibilities in Bembe. Crucially, it does so without being forced to introduce drastic changes to the operation *Agree*. A further advantage of this account of subject marking is that it predicts the ungrammaticality of subject-object reversals and the restriction on expletive default-agreement and locative inversions to appear only with unaccusative and copular verbs in Bembe.

Object arguments can also be cross-referenced through inflectional morphemes on the verb, a process referred to as object marking. One important difference between subject and object marking is the fact that while subject markers are obligatory (at least as far as declarative clauses are concerned), object markers are in complementary distribution with the object arguments they cross-reference. The Bembe examples in (6) show that object markers can replace object DPs, as shown in the example in (6b), but cannot co-occur with an in-situ object, as shown in (6c).

- (6) a. *Mwana a-a-yak-a ngyo?a.*  
 1child 1SM-N.PST-kill-FV 9snake  
 "The child has killed a snake."
- b. *Mwana a-a-ya-yak-a.*  
 1child 1SM-N.PST-9OM-kill-FV  
 "The child has killed it."
- c. \**Mwana a-a-ya-yak-a ngyo?a.*  
 1child 1SM-N.PST-9OM-kill-FV 9snake  
 "The child has killed a snake."

In the literature on Bantu object marking, it is commonly assumed that if object markers can double local object DPs, they should be analysed as grammatical agreement morphemes. If, in turn, they cannot double an object argument locally, i.e. when they show complementary distribution with object arguments with respect to the inflectional

domain, as in (6c), they should be analysed as being incorporated pronouns (see, for example, Buell 2005; Adams 2010; van der Spuy 1993; Zeller 2009, 2012 for Zulu; Zerbian 2006 for Northern Sotho; Byarushengo et al. 1976; Duranti & Byarushengo 1977; and Tenenbaum 1977 for Haya; Henderson 2006a,b for a number of languages). However, the variation in object marking across the Bantu language continuum (Marten, Kula & Thwala 2007) and the perceived inability of pronominal incorporation analyses to account for them leads Riedel (2009) to dismiss the agreement/pronoun dichotomy altogether. Instead, she claims that a general analysis of Bantu object marking as an agreement phenomenon is to be preferred.

The results of a number of diagnostics standardly employed in the literature show that in Bembe object DPs are dislocated in the presence of object markers, which leads me to conclude that object markers must be pronominal rather than agreement morphemes. This conclusion is supported by (i) an obligatory intonation break, (ii) interpretational differences in the presence of object markers, (iii) the co-occurrence restrictions between object marking and indefinite, focused, relativised, passivised elements and negative-polarity items, and (iv) the ungrammaticality of certain orderings of object-marked objects and other elements. It follows that object markers, as they display the properties predicted by a pronominal incorporation analysis, must be pronominal in the sense of being theta-role bearing arguments. In analogy to Bembe subject markers, I propose that object markers are defective clitics, more specifically  $\phi$ Ps (Roberts 2010a,b) which are merged in argument position and subsequently incorporate into  $\nu$  after the verb has moved from V to  $\nu$ . While the proposed analysis is an Agree-based approach, it is able to account for the pronominal properties of Bembe object markers.

## **1.2 Bembe**

### **1.2.1 Basic facts about the language and its speakers**

Bembe is a Narrow Bantu language spoken in the Democratic Republic of Congo (DRC) and parts of Tanzania. Alternative names include Beembe, Ebembe, Ibembe or Kibembe. In Maho's (2009) updated version of Guthrie's (1967/1971) geographically influenced classification system, Bembe is classified as D54, and the code assigned to the language by the ISO 639-3 standard is [bmb]. It should not be confused with the distinct languages Bembe [beq] (H11; Maho 2009) spoken in the Republic of the Congo



(Congo-Brazzaville) and Bemba [bem] (M42; Maho 2009) spoken in the southeast Katanga Province of the DRC, Zambia, and Tanzania.

Bembe is primarily spoken in the Fizi territory, which is situated in the South Kivu province of the Democratic Republic of the Congo (DRC). The province extends from the North to the South of the Western coastline of Lake Tanganyika and is further sub-divided into four territorial collectivities: Lulenge, Mutambala, Tanganyika and Ngandja. Formerly, a fifth territorial collectivity called Itombwe formed part of the South Kivu region, but has since been incorporated into the adjacent northwestern Mwenga territory. Despite the annexation, Itombwe territory is still regarded by the Babembe as the cradle of their people *and* language. The latest figure concerning the number of L1 Bembe speakers in the DRC is given as 252,000 by the United Bible Society (as of 1991) (Lewis et al. 2014) although this is only an estimate.

Bembe is also spoken by certain communities in Tanzania, namely in the Kigoma Region, more specifically in the Kigoma Vijinini district, along the shore of Lake Tanganyika and in the town of Kigoma to the north to the Gombe National Park. However, as Ethnologue (2014) points out, the group of Bembe speakers in Tanzania is heterogeneous. One part is made up of Tanzanians citizens, while the other consists of immigrants from the DRC, forced out of their country due to the recent Congolese wars and subsequent conflict(s). There are no figures available with respect to the number of Bembe speakers in Tanzania.

According to Ethnologue (Lewis et al. 2014), which uses the Expanded Graded Intergenerational Disruption Scale (EGIDS) (Lewis and Simons 2010) as a basis to evaluate the overall development versus endangerment of the language, Bembe is classified as being a Level 5 (developing) language, i.e. “the language is in vigorous use, with literature in a standardized form being used by some though this is not yet widespread or sustainable.” This is in accordance with the layman’s judgment of my language consultants with respect to the status of the language.

There exists a Bible translation, which has been published in 1990. Other previous studies on the language, more academic in scope and to which I had access, include a sketch of the grammar in the form of an MA dissertation (Mutombo Huta 1973), another MA dissertation on the verbal system of Bembe (Mulengwa 2010) and an undergraduate dissertation on the derivational morphology in Bembe (Asende Pondamali 1996). However, it seems that all these works describe other varieties or dialects of Bembe than the one described within this thesis. While the similarities leave no doubt that they are varieties of Bembe, systematic phonetic, phonological and lexical

differences strongly suggest that they are different from the one described in this thesis, the one spoken by my informants in the territory of Itombwe. This has also been pointed out independently by various language informants on a number of occasions and upon being confronted with data from mentioned sources. Previous studies of Bembe which I am aware of but which I could not access include some non-published notes on (some variety of) Bembe by Meeussen (1951) and a morphological study of the language by Boungou (19—).

The approximate extension of the area in which Bembe is spoken is shown in Fig. 1.



Fig. 1: GEOGRAPHICAL MAP OF BEMBE EXTENSION

### 1.2.2 The data

The database on which this thesis is based was built up in weekly sessions over the course of two years in London, UK. It mainly consists of elicited data, which was used for grammaticality judgment tests, though it also contains unsolicited examples which the language informants offered spontaneously during data collection session. The data was elicited from native language speakers who are all from the same region of the South Kivu region/Fizi territory in which Bembe is spoken, Itombwe. All of the informants speak Bembe as their first language, and show native-like or high proficiency in their second, third and fourth languages Swahili, French and English.

I have worked with 3 language informants directly in London: Eky Esenga, 53 years old, Yvonne Asha Babilye Esenga, 42 years old, and Yassin Toye, 42 years old. Moreover, language interviews were also conducted via phone or email with four additional informants, three of whom live in Belgium, i.e. Pierre Mmunga Mulengwa (Mas1)<sup>1</sup>, Charles Asukulu Mulengwa (Mas2), and Jean-Claude Mulanga, and one of whom lives in the USA, Asukulu Ilelwa Etoka.

Language elicitation sessions usually took place on a weekly basis, for a duration of 1 ½ - 2 hours. All sessions were held in English. The language informants would sometimes offer unsolicited explanation attempts of grammatical phenomena, in the course of which they resorted to French examples for clarification, as was often the case during data collection on object marking. In other cases, translations of words were given in French, in which case I ensured that the French gloss would be translated appropriately into English, for example with respect to the subcategorisation requirements of verbs.

As regards the transcription of the data, this thesis largely follows the Leipzig Glossing Rules (Bickel, B., B. Comrie & M. Haspelmath 2004). The Bembe examples in this thesis all consist of three lines. The first line is the Bembe example, the second line the morpheme-by-morpheme gloss in English, and the third line a free translation. In some cases, especially when word order is concerned, a fourth line has been added in order to illustrate the literal translation of the example. Ungrammatical examples are marked with an asterisk (\*), while infelicitous examples are marked with #. In such cases, the third line will give a gloss of the intended meaning. Grammatical morphemes (the abbreviations of which are explained in the list of abbreviations) are given in small

---

1 *mas* 'twin'

capitals, while lexical morphemes appear in lower case. This is illustrated by the examples in (7).

- (7) a. *Mmohe/mnyaka wa-a-chw-el-a olya.*  
 3wind/3wind 3SM-PRES-come-APPL-FV 17LOC-DEM.dist  
 (Lit. “Wind comes there.”)  
 “The wind comes from there.”
- b. *\*Ba-a-chw-a baana.*  
 2SM-N.PST-come-FV 2child  
 (Int. “(Some) children have arrived.”)
- c. *\*Beni a-a-chw-a?*  
 1who 1SM-N.PST-come-FV  
 (Int. “Who has arrived?”)

The numbers in the morpheme-by-morpheme gloss in the second line refer to noun classes. In case of verbs, the noun class of subject and object markers is additionally indicated by SM and OM, respectively. For relative markers, REL is added to the noun class. In the case of nominals, only the number of the noun class is indicated, except for locative noun classes 16-18 in which cases LOC is added to the gloss to indicate that they belong to the class of locative markers, which attach to the whole nominal stem and not just the nominal base like class markers. Moreover, verbal morphemes are separated by a dash, nominal morphemes are not separated from the nominal, except for locative class markers. This is illustrated in (8).

- (8) *M-numba mu-le baana.*  
 18LOC-9house 18SM-COP 2child  
 (Lit. “In the house there are children.”)

Bembe displays a number of portmanteau morphemes, i.e. single morphemes that encode two or more grammatical functions in one morpheme. The different grammatical functions of portmanteau morphemes are separated by a dot in the gloss, as shown in (9).

- (9)        *Shi-iky-e*                    *mtu.*  
              NEG.1SG-know-FV    1person  
              (Lit. “I do not know a person.”)  
              “I do not know anyone.”

### 1.3 Theoretical background

The analysis of the topics of the theoretical part of the thesis is couched within the minimalist model of generative grammar introduced in Chomsky (1993, 1995, 2000, 2001, 2004, 2005). The Minimalist Program or simply Minimalism, as it is also referred to, is a research program rather than a theory (Chomsky 2000: 92) that builds on a set of ideas first expressed in the Standard Theory (Chomsky 1957, 1965), the Extended Standard Theory (Chomsky 1973), the Revised Extended Standard Theory (Chomsky 1977) and Government and Binding (henceforth GB; Chomsky 1981, 1986). It is minimalist in the sense that the language faculty “provides no machinery beyond what is needed to satisfy minimal requirements of legibility and that it functions in as simple way as possible” (Chomsky 2000: 112-113). This is expressed in two economy considerations, which play a central role within the MP: the economy of derivation and the economy of representation. Chomsky (1995: 92) mandates that the “derivation contain no superfluous steps, just as representation contain no superfluous symbols”, thereby eliminating any unnecessary movement operation and structures.

Some of the main assumptions made in GB have been revised extensively in the transition to Minimalism, such as those concerning the Interface Levels. While GB maintained that there are four levels of representation with linguistic significance – Deep Structure (DS), Surface Structure (SS), Logical Form (LF) and Phonological Form (PF) (Chomsky 1981) – this is reduced to LF and PF in Minimalism (Chomsky 1993).

These interface levels, which contribute to the semantics and phonology, respectively, are linked with the interpretability of formal features. Lexical items enter the derivation equipped with formal features, which are the driving force behind the computation and responsible for triggering the derivational operations Move and Agree (Chomsky 1995, 2000). The most important ones are the EPP, abstract Case and  $\phi$ -features. The EPP feature (Chomsky 1981) requires the specifier of the head bearing the feature to be filled and enters the derivation without a value, as it does not contribute to the meaning of an item (Chomsky 2005).  $\phi$ -features, which contain the semantic

information of person, number and in some languages gender, in contrast, are interpretable on nominals in the sense that they are visible at the LF interface. The heads of functional categories also bear  $\phi$ -features. These, however, are uninterpretable and unvalued since they do not contribute to the semantic interpretation at the LF interface, and enter the syntax unvalued, being assigned values in the course of the derivation. If an uninterpretable feature reaches LF, the derivation is said to crash. For a derivation to converge, all uninterpretable features that are not accessible at the interface levels have to be deleted given the Principle of Full Interpretation (FI).<sup>2</sup> The valuation and deletion of uninterpretable features are accomplished via the operation Agree.

The cognitive system of the language faculty consists of a computational system (CS), the locus of the derivation where the syntactic structures are constructed, and a lexicon. The relation between the CS (including LF and PF) and lexicon is as illustrated in FIG. 2.

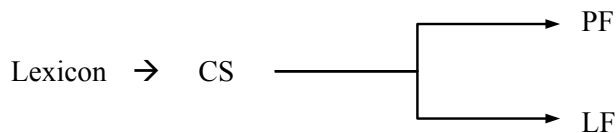

FIG. 2: COGNITIVE SYSTEM OF THE LANGUAGE FACULTY

The starting point in the computational system is the ‘Numeration’. The numeration is “a set of pairs (LI, i), where LI is an item of the lexicon and i its index, understood to be the number of times LI is selected” (Chomsky 1995: 225). Linguistic expressions are structured in the form of the pair (a, b). The first member of the pair, i.e. a, stands for the legitimate objects that are interpretable at PF, while the second member, i.e. b, stands for the legitimate objects that are interpretable at LF.<sup>3</sup>

Once the linguistic items are chosen from the lexicon, two operations apply, i.e. Select and External Merge. The operation Select dictates that every listed item in the

2 Chomsky (1995: 27) explains “[t]he principle FI is assumed as a matter of course in phonology; if a symbol in a representation has no sensorimotor interpretation, the representation does not qualify as a PF representation. This is what we called the ‘interface condition’. The same condition applied to LF also entails that every element of the representation have a (language independent) interpretation.”

3 Chomsky claims “[E]ach language will determine a set of pairs  $(\pi, \lambda)$  ( $\pi$  drawn from PF and  $\lambda$  from LF) as its formal representations of sound and meaning, [...] Parts of the computational system are relevant only to  $\pi$ , not  $\lambda$ : the *PF component*. Other parts are relevant only to  $\lambda$ , not  $\pi$ : the *LF component*. The parts of the computational system that are relevant to both are the *overt syntax* (Chomsky 1995: 169). [emphasis in the original]

enumeration be exhausted for a derivation to converge. The operation External Merge, in contrast, combines the item  $\alpha$  with the item  $\beta$  to build a complex item  $K$ , which is a projection of either  $\alpha$  or  $\beta$ . In Chomsky's own words (1995: 226), Merge is an operation that "takes a pair of syntactic objects ( $SO_i, SO_j$ ) and replaces them by a new combined syntactic object  $SO_{ij}$ ", as illustrated in (10).

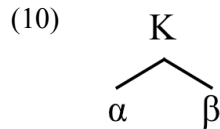

Note that once two items are merged, new elements, e.g. features or indices, cannot be introduced in the course of the derivation. Only the rearrangement of existent lexical properties is allowed. This is captured by the Inclusiveness Condition (Chomsky 1995: 228), as defined in (11).

(11) Inclusiveness Condition:

Any structure formed by the computation is constituted of elements already present in the lexical items selected for  $N$ ; no new objects are added in the course of computation, apart from the rearrangement of lexical properties.

In the diagram in (10), two types of relations are of importance: containment and sisterhood.  $K$  is said to immediately contain  $\alpha$  and  $\beta$ , while  $\alpha$  is said to be in a sisterhood relation to  $\beta$ . The relations of containment and sisterhood expressed in (10) derive the notion of *c-command*, as defined in (12) (cf. Chomsky 2000: 116)

(12)  $\alpha$  *c-commands*  $\beta$  if  $\alpha$  does not contain, nor is contained within,  $\beta$  and the node  $K$  that immediately contains  $\alpha$  immediately contains  $\beta$ .

The definition implies that  $\beta$  also *c-commands*  $\alpha$ . This is because  $\beta$  does not contain  $\alpha$ , and  $\alpha$  and  $\beta$  are immediately contained within  $K$ . This mutual relationship is referred to as *symmetrical c-command*. Symmetrical *c-command* contrasts with *asymmetrical c-command*, illustrated in (13), a relation under which  $\beta$  *c-commands* both the elements  $\delta$  and  $\epsilon$  but in which neither  $\delta$  nor  $\epsilon$  *c-command*  $\beta$ .

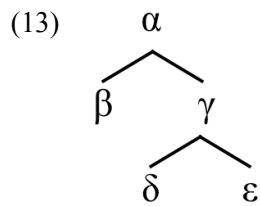

In (13),  $\beta$  and  $\gamma$  are contained within  $\alpha$  and mutually c-command each other. By virtue of c-commanding  $\gamma$ ,  $\beta$  also c-commands  $\varepsilon$  and  $\delta$ . However, the latter two do not c-command  $\beta$  because they are not immediately contained within  $\alpha$ . We will see below how c-command is a crucial factor in the operation Agree. With this in mind, let us see how the derivation would typically take place in the case of an English declarative clause, as shown in (14).

(14) *Vladimir challenged the Western World.*

In the derivation illustrated below in (15), I assume that a version of the VP-internal Subject Hypothesis (Koopman & Sportiche 1991) is correct and that the subject accordingly originates within the VP. A functional light head  $\nu$  is merged with VP, which derives  $\nu'$ , which in turn is merged with the external argument (i.e. the subject *Vladimir*). Subsequently,  $\nu P$  is merged with the functional head T, which is equipped with an EPP feature, requiring the subject to raise from the spec, $\nu P$  position to spec,TP.

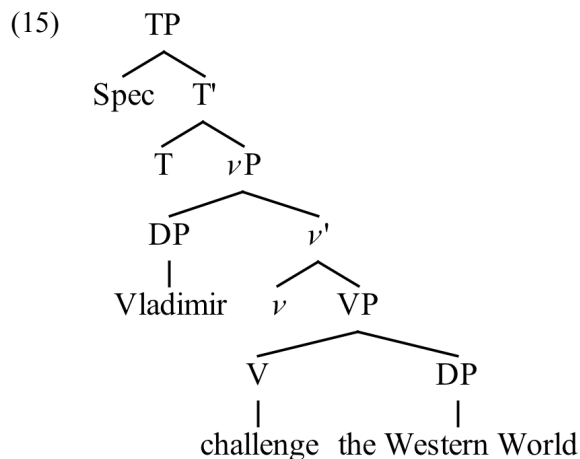

Once the operations Select and Merge have been completed, other further operations are needed to for the derivation to be convergent, one of them being the



deletion of uninterpretable features before LF. In earlier version of Minimalism, uninterpretable features were deleted by means of feature checking, a process by which the uninterpretable features are made “invisible to LF but visible to the computation” (Chomsky 1995: 280), and it was feature checking which triggered the operation Move (also referred to as movement or Internal Merge) to apply. Feature checking took place in a specifier-head configuration between goal and probe. In the most recent version of Minimalism, feature checking has been replaced by the process of feature valuation within the operation Agree. With the advent of the latter, the role of the operation Move has been restricted from being feature-driven to being driven only by the need to satisfy an EPP feature on a functional head.

By arguing that feature checking via feature-driven movement is not consistent with Minimalist economy conditions, Chomsky advocates a long-distance agreement operation that involves matching interpretable with uninterpretable features (Chomsky 1995; ch.4) or valuing matching but unvalued features (Chomsky 2001), able to capture the facts with less theoretical machinery. One prerequisite for the operation Agree is the operation Match. Agree relates two elements with active features, a probe and a matching goal, to each other. The feature that is responsible for rendering a goal active is assumed to be an unvalued uninterpretable Case feature, which will be valued by a matching interpretable Case feature on the probe. The probe also has unvalued  $\phi$ -features which will be valued by the valued interpretable counterparts on the matching goal. In addition, probe and goals have to display a certain configuration for Agree to apply, at which point we return to the notion of c-command: the probe agrees with the closest goal it c-commands (Closest Match Principle). As a result of the operation Agree, all unvalued, uninterpretable features will have been valued and deleted before LF. A probe  $\alpha$  agrees with a goal  $\beta$  under the conditions listed in (16) (cf. Chomsky 2001: 122).

- (16) a.  $\alpha$  has uninterpretable  $\phi$ -features.  
 b.  $\beta$  has matching interpretable  $\phi$ -features.  
 c.  $\beta$  is active by virtue of having an unvalued Case feature.  
 d.  $\alpha$  c-commands  $\beta$ .  
 e. There is no potential goal  $\gamma$  intervening between  $\alpha$  and  $\beta$ .

Features such as the EPP that are not subject to feature valuation under long-distance Agree, are valued by the Last-resort operation Move. Under current

assumptions, Agree is a prerequisite for the operation Move, thus the latter is dependent on the former. I will show in Chapters 3 and 4 how Bantu languages challenge this assumption and approaches that have been devised to address this problem (Baker 2003, 2008; Carstens 2005; Henderson 2006, 2011a). The derivations in (17) and (18) illustrate how the derivation within an Agree-based theory, as described above, proceeds step-by-step. The tree diagram in (17) shows the moment after Select and External Merge in which the elements are equipped with features. Uninterpretable features enter the derivation unvalued while interpretable ones do so valued. Note that for reasons of expository simplicity in (17), I will disregard the fact that unvalued features are valued once they enter the derivation. Strictly speaking, though, the representation in (17) will never be a possible stage in a derivation.

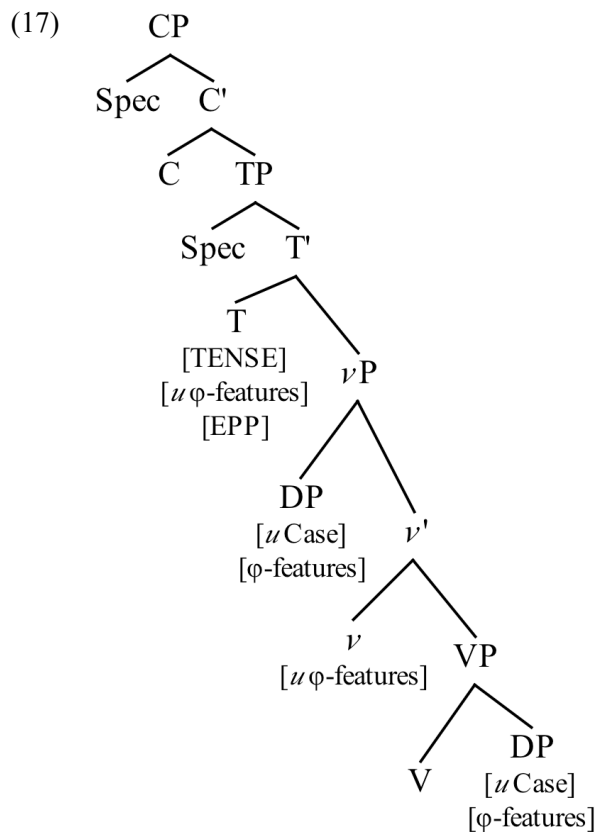

The tree diagram in (18) illustrates the process of valuation and deletion of uninterpretable features under the process Agree. The verb short-moves to the functional head  $\nu$ , which probes the c-commanded domain and finds a goal with matching features in the object  $DP_j$ . The uninterpretable  $\phi$ -features of  $\nu$  and the uninterpretable Case feature of the  $DP_j$  are valued and deleted (indicated by

strikethrough in the diagram). Note that the deletion of  $\phi$ -features refers to the derivation of LF but not that of PF since their value determines their pronunciation. Subsequently, the verb adjoins to the functional head T, the unvalued  $\phi$ -features of which forces it to probe the c-commanded domain for a matching goal. Under the assumption of Closest Match, according to which the closest goal will be selected for an Agree relation, the subject  $DP_i$  in the specifier position of  $\nu P$  will be selected. The established Agree relation values and deletes the uninterpretable features of T. However, T is also equipped with an EPP feature in need of valuation. As the operation Agree is unable to satisfy the EPP requirement, the ‘last resort’ operation Move ultimately applies and the subject is raised from the spec, $\nu P$  position into spec,TP.

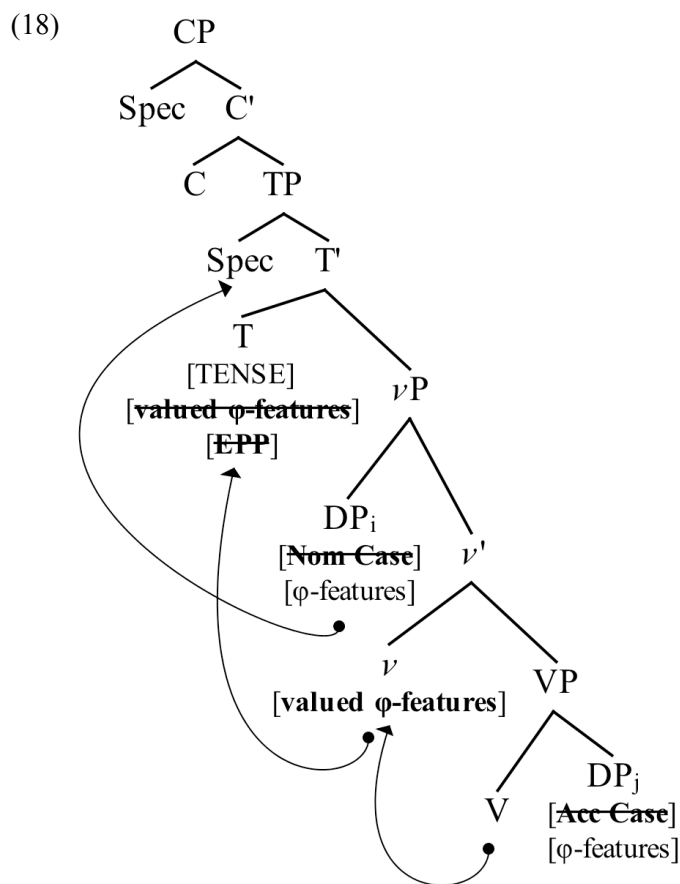

One of the last changes in the transition from the earlier (Chomsky 1993, 1995) to the later (Chomsky 2000, 2001, 2004, 2005) versions of Minimalism I introduce is the introduction of phases. It is argued that a derivation proceeds phase by phase: uninterpretable features are valued and deleted in phases, and the operation Spell-out thus executed cyclically. Once a phase is completed, it is transferred to LF and PF. Phases that have been transferred to the interface levels become inaccessible for further

operations. However, the head and the left edge of the phase can be involved in further operations. This is expressed in the *Phase Impenetrability Condition*, as stated in (19) (cf. Chomsky 2000: 108).

- (19) In Phase  $\alpha$  with head H, the domain of H is not accessible to operations outside  $\alpha$ , only H and its edge are accessible to such operations.

Only CPs and  $\nu$ Ps are assumed to be phases because their heads are equipped with  $\phi$ -features. TPs, in contrast, are not, as they do not have any  $\phi$ -features, although the latter are transferred from C to T in a process referred to as *Feature Inheritance* (Chomsky 2005, 2007, 2008) (but see Carstens 2005; Henderson 2006, 2011a). In Chomsky (2008: 143), “T manifests the basic tense features if and only if it is selected by C (default agreement aside); if not, it is a raising (or ECM) infinitival, lacking  $\phi$ -features and basic tense”. Thus it is the features of C that T values when probing for a goal. The latter can either agree long-distance with a goal under Agree or raise as far as spec,TP. Further movement to spec,CP, however, is prohibited since the goal is deactivated for further Agree relations once it enters an Agree relation with T. Besides the mentioned tense feature on C, C and  $\nu$  also transfer their  $\phi$ -features and an EPP feature to T (re-defined as *Edge feature* in Chomsky 2008), the latter of which triggers movement of the goal to the specifier of the phase head. Chomsky assumes that, in analogy to T and C, V inherits features from  $\nu$  with the result that the goal (i.e. the object) is raised into the outer specifier of  $\nu$ P in order to value and delete uninterpretable features.

#### **1.4. Outline of the thesis**

The remainder of the thesis is structured as follows: Chapter 2 forms the first part of the thesis and presents a grammatical description of Bembe, which covers aspects of the phonology, morphology and syntax, with the focus on the latter two domains. Chapters 3 and 4 form the second part of the thesis, which is theoretical in scope. Chapter 5 concludes the thesis by summarising the findings made in the preceding chapters, discusses open issues and points towards aspects within the Bembe grammar which merit more detailed research.

Chapter 3 examines object marking in more detail and focuses on the sentential object marking patterns exhibited in Bembe. The phenomenon in question is illustrated by examples such as (20). (20a-b) illustrate how objects can either figure as DPs or can

be replaced by corresponding object markers in Bembe. The co-occurrence of object DPs and object markers however is prohibited, as show in (20c).

- (20) a. *Baana ba-a-kol-a bilewa.*  
2child 2SM-N.PST-buy-FV 8food  
“The children have bought (some) food.”
- b. *Baana ba-a-bi-kol-a.*  
2child 2SM-N.PST-8OM-buy-FV  
“The children have bought it.”
- c. \**Baana ba-a-bi-kol-a bilewa.*  
2child 2SM-N.PST-8OM-buy-FV 8food  
(Int. “The children have bought (some) food.”)

Chapter 4 examines the domain of subject marking in more detail and focuses on the verb-marking patterns and different word orders exhibited in Bembe. The phenomenon in question is illustrated by examples such as (21).

- (21) a. *Baana ba-koch-ile bilewa.*  
2child 2SM-buy-PST 8food.  
“The children bought (some) food.”
- b. *Ba-koch-ile bilewa.*  
2SM-buy-PST 8food.  
“They bought (some) food.”

Chapter 5 summarises the findings made in this thesis, discusses open issues in the grammar of Bembe and points towards potentially interesting questions for future research.

## CHAPTER 2 – A GRAMMATICAL DESCRIPTION OF BEMBE

### 2.1 Phonetics

#### 2.1.1 Vowels

Bembe has a 7-vowel system, which consists of three front (i, e, ε), one central (a) and three back (u, o, ɔ) vowels. The complete vowel inventory is shown in Table 1.

Degree of aperture	Front	Central	Back
Closed	i		u
Semi-closed	e		o
Semi-open	ε		ɔ
Open		a	

Table 1: BEMBE VOWEL INVENTORY

The phonemic value of the vowel inventory can be shown through the following list of minimal pairs (22)-(27):

(22) a. [e/i]:

*isecha* ‘to lead’  
*isicha* ‘to grind’

b. [e/ε]:

*éma* ‘monkey’  
*-ema* ‘to strongly refuse’

c. [e/u]

*ielá* ‘to drop’  
*iula* ‘to resuscitate sb.’

d. [e/o]

*éé* ‘what’  
*óó* ‘chicken’

e. [e/ɔ]

*eto* ‘thing’  
*oto* ‘somewhere’

f. [e/a]

*elumbé* ‘altar’  
*elumba* ‘person of fame’  
*itela* ‘to lay an egg’  
*itala* ‘to shine’



c. [a/ɔ]

*ianga* ‘to frighten, guinea fowl’

*iɔnga* ‘to follow’

(26) a. [u/o]

*uu* ‘flea’

*óó* ‘chicken’

b. [u/ɔ]

*ibula* ‘to be numerous’

*ibɔla* ‘to decompose, decay’

(27) [o/ɔ]

*i-tota* ‘to beat/hit sb./s.th.’

*i-tɔta* ‘to get wet’

*i-bola* ‘to pull, drag’

*i-bɔla* ‘to go rotten’

*iomba* ‘to transport by water’

*iɔmba* ‘to sweep, to clean a plate with one’s finger’

There is no contrast between long and short vowels in Bembe. Moreover, unlike other Bantu languages, such as Zulu or Chicheŵa, it seems that Bembe does not have any form of automatic lengthening, such as penultimate lengthening, either.

#### *Liaison*

Liaison is (re)-syllabification that targets vowels on word boundaries. Given the syllable structure (C)V(X) displayed in Bembe, liaison typically happens in a sequence of two words of which the first one ends in a vowel and the second one starts with one.

(28) *na (e)bo* > [nabo]

“of them”

#### *Epenthesis*

The inclusion of an extension into the verb can result in the addition of an epenthetic vowel (presumably to retain the CV syllable structure).



- (29) a. *Ba-a-hikech-a*.  
 2SM-N.PST-teach-FV  
 “They have taught.”
- b. *Ba-a-hikech-iw-a*.  
 2SM-N.PST-teach-PASS-FV  
 “They have been taught.”

### *Tones*

Bembe, like the majority of Bantu languages, is a tone language. It presents an inventory of four tones: two simple tones, a high (´) and a low one (˘), and two complex tones, a rising (ˆ) and a falling one (ˆ). I do not have enough data that could determine whether the latter two complex tones are independent basic tones or combinations of high and low tones. A note on the notation of tones is in order here. Throughout this thesis, low tones are not marked while high tones are always indicated by (´). Only in those cases in which the contrast between a low and a high tone induces a difference in meaning, is the low tone marked (˘). This, for instance, is the case in the list of minimal pairs in (30), which illustrates the phonological status the contrast between high and low tones has in Bembe.

- (30) a. *ichíka* ‘to burn’ vs. *ichika* ‘to bite’  
*ikónnda* ‘to thinnen’ vs. *ikònda* ‘to marry’  
*ilónnda* ‘to be difficult’ vs. *ilònda* ‘to search’  
*ibámmba* ‘to warm/heat up’ vs. *ibámmba* ‘to bet’  
*ihéma* ‘to breathe’ vs. *ihèma* ‘to put on weight’
- b. *óó* ‘chicken’ vs. *òò* ‘grandmother’

### **2.1.2 Semi-vowels**

Bembe features the two semi-vowels [y] and [w], both of which occur as onsets and nuclei of syllables and at the beginning of words, as illustrated in (31).

- (31) a. [y]:
- |                   |                           |
|-------------------|---------------------------|
| <i>ya.ne</i>      | ‘yours’                   |
| <i>bya.m.milu</i> | ‘black’                   |
| <i>ilya</i>       | ‘to eat’                  |
| <i>ilɛ.ya</i>     | ‘to prolong, to lengthen’ |
| <i>bo.yá</i>      | ‘marriage’                |
- b. [w]:
- |               |             |
|---------------|-------------|
| <i>wa.ne</i>  | ‘my’        |
| <i>mwaana</i> | ‘child’     |
| <i>i.ʔwa</i>  | ‘die’       |
| <i>i.wa</i>   | ‘to finish’ |

The semi-vowel /w/ is usually derived from the underlying back vowels [u], [o] and [ɔ], whereas [y] is derived from [i] or [e].

### 2.1.3 Consonants

#### *Consonant inventory*

Bembe presents a relatively small inventory of 20 consonants, as shown in Table 2.

	Labial		Dentals		Palatal		Velar		Laryngeal	
Sonority	+	-	+	-	+	-	+	-	+	-
Plosive	b	p	(d)	t	(dʒ)	tʃ	(g)	k		ʔ
Fricative		f		s		ʃ				h
Nasal	m		n		ɲ		ŋ			
Lateral				l						
Semi-vowel	w				y					

Table 2: BEMBE CONSONANT INVENTORY

As regards the spelling in this thesis, the phonemes /tʃ/, /ʃ/, /ɲ/ and /ŋ/ are represented with the symbols *ch*, *sh*, *ny* and *ng*, respectively.

#### *Nasals*

The three phonemes /d/, /dʒ/ and /g/ are allophones of the three phonemes /t/, /tʃ/ and /k/, respectively. They are always prenasalised (/<sup>n</sup>d/, /<sup>n</sup>dʒ/ and /<sup>n</sup>g/) and do not appear in isolation.

- (32) a. *ndeɔ* ‘banana’          b. *ndzikye* ‘rivers’  
*myenda* ‘clothes’                *ηandzi* ‘cold’  
*ɔlonda* ‘difficulty’                *itendza* ‘to speak’  
  *ndchuele* ‘hair’
- c. *ngyála* ‘fingernails’  
*ngyála* ‘hunger’  
*engwe* ‘leopard’  
*lobonga* ‘house in the centre of village (social), church’

*Nasal harmony*

Bembe features nasal harmony, the process by which the nasality of a nasal spreads to the approximant /l/ which follows it. The process targets the past suffix *-ile-* and the applicative extension *-el-*. As a result, these appear as [ine] and [en], respectively, in such environments, as illustrated in (33) & (34).

- (33) a. *A-koch-ile*          *mleka*.  
1SM-buy-PST          3beans  
“S/he bought beans.”
- b. *A-mon-ine*          *ewe*.  
1SM-see-PST          him  
“S/he saw him”
- c. *Na-chimin-ine*.  
1SG-go.lost-PST  
“I got lost.”
- d. *Ba-som-ine*          *etabo*.  
2SM-read-PST          7book  
“They read a book.”
- (34) a. *Ba-a-kol-el-a*          *baana mleka*.  
2SM-N.PST-buy-APPL-FV          2child 3bean  
“They have bought the children beans.”
- b. *Eky a-a-tɔm-en-a*          *baana bilewa*.  
1Eky 1SM-N.PST-taste-APPL-FV          2child 8food  
“Eky has tasted food for the children.”

- c. *David a-lo-som-en-a baana etabo.*  
 1David 1SM-PST-read-APPL-FV 2child 7book  
 “David has read a book to the child.”

Nasal harmony is triggered regardless of whether the responsible nasal is contained within the radical (35a-b) or whether it is actually introduced by an extension (35c).

- (35) a. *mtu wa-chimin-ine*  
 1man 1REL-go.missing-PST  
 “the man that went missing”
- b. *Mbochi ya-lwan-ine na ngyoɔa.*  
 9goat 9SM-fight-PST with 9snake  
 “The goat fought the snakes.”
- c. *Ba-somb-an-ine.*  
 2SM-hate-REC-PST  
 “They hated each other.”

Note that nasals in nasal clusters do not induce spreading of the nasal to the approximant, as illustrated in (36).

- (36) a. *A-tend-ile.*  
 1SM-speak-PST  
 “S/he spoke.”
- b. *Twa-teng-ile.*  
 1PL-shake/move-PST  
 “We moved.”
- c. *A-a-ong-el-a Iddi numba.*  
 1SM-N.PST-repair-APPL-FV 1Iddi 9house  
 “S/he has repaired a house for Iddi.”
- d. *A-a-kang-el-a Mary mbama*  
 1SM-N.PST-wrap-APPL-FV 1Mary 3lunch.box  
 “S/he has wrapped/packed a lunch box on behalf of/for Mary.”

### *Meinhof's rule*

Meinhof's rule or law is a phonological process by which a voiced consonant in a nasal cluster [ᵐb], [ᵐd], [ᵐj], [ᵐg] changes, depending on the language involved, either into a long (geminate) nasal or a simple nasal in those environments in which it is followed by another nasal cluster.<sup>4</sup> It is a common phonological rule in a number of Bantu languages, although its manifestation varies greatly from language to language. In Bembe, however, Meinhof's rule does not apply. If a voiced plosive, i.e. /b/, /d/ or /g/, is preceded by a nasal consonant and followed by syllable consisting of a nasal cluster with a nasal consonant and a voiced plosive, the voiced plosive will not be subject to Meinhof's rule, as illustrated in (37).

- (37) a. *mbangya* 'traitor'  
          *mbondo* 'Bembe' (older denomination)  
          *mbembe* 'Bembe'
- b. *ndendele* 'to speak on my behalf'

#### **2.1.4 Syllable structure**

Words in Bembe present a syllable structure of the type (C)V(X). Additionally, nasals can be syllables, too. The syllabic structure of Bembe words is illustrated in Table 3.

---

<sup>4</sup> In earlier discussion of the phenomenon, it was considered to be a case of *dissimilation* of pre-nasalised consonants in successive syllables. Subsequently to Meeussen's (1965: 25) observation that Meinhof's rule in the language Ganda yields a geminate nasal rather than a simple one, it was re-analysed as a case of *assimilation* (see also Luganda and Bemba; Herbert 1977). In those languages that do not display geminate nasals, such as Lumasaaba or Kikuyu, Meinhof's rule is envisaged as a process of assimilation and subsequent de-gemination.

Syllable	Example	Translation
V	<i>e.ta.bo</i>	‘book’
VV	<i>óó</i>	‘chicken’
SV	<i>i.wa</i>	‘to finish’
N	<i>m.tu</i>	‘person’
	<i>m.mo<sup>n</sup>g</i>	‘next’
NV	<i>i.mo.<sup>n</sup>wa</i>	‘to be seen’
CV	<i>bi.le.wa</i>	‘food’
CSV	<i>i.ɔwa</i>	‘to die’
CSVV	<i>mwaa.na</i>	‘child’
CVC	<i>i.sol.a</i>	‘to drink’

Table 3: BEMBE SYLLABIC STRUCTURE

## 2.2 Nouns and nominal categories

The aim of this section is to give a morphological description of the elements that can appear in the nominal domain in Bembe. Before presenting the different nominal categories, the properties of nouns, the system of categorizing them into noun classes and a number of nominalisation strategies will be presented.

### 2.2.1 Nouns and the noun class system

In Bembe each nominal belongs to a particular noun class. The noun class a nominal belongs to is discernible from its prefix – which is traditionally said to encode the grammatical features of number and gender (cf. Corbett 1991) – and the concord and agreement patterns. Once a nominal root is paired with the class prefix, the result is a full-fledged noun stem specified for number and gender features, as illustrated in the template in (38).

(38)	Class prefix + Nominal root	Nominal stem
	<i>m-</i> <i>tu</i>	> <i>mtu</i> ‘person’
	<i>to-</i> <i>nyoni</i>	> <i>tonyoni</i> ‘birds’

Table 4 shows the noun class system of Bembe, which comprises 19 classes. Some nouns only consist of a nominal root, and it is common practice to assume that

they have a zero-prefix ( $\emptyset$ ). Where one class shows more than one noun class prefix, these are allomorphs that arise under certain phonological conditions, namely when it precedes a vowel-initial noun stem.

Class	Nominal prefix	Example(s)	Gloss
1	<i>m-</i>	<i>mtu</i>	‘person, man’
	<i>mw-</i>	<i>mwáana</i>	‘child’
1a	$\emptyset$ -	<i>òò</i>	‘grandmother’
2	<i>ba-</i>	<i>batu</i>	‘people’
		<i>baana</i>	‘children’
2a	$\emptyset$ -	<i>òò</i>	‘grandmothers’
3	<i>m-</i>	<i>msea</i>	‘girl’
	<i>mw-</i>	<i>mwenda</i>	‘piece of clothes’
4	<i>mi-</i>	<i>misea</i>	‘girls’
	<i>my-</i>	<i>myenda</i>	‘clothes’
5	<i>(h)i-</i>	<i>hibwe,</i>	‘stone’
		<i>ike, iteté</i>	‘egg’, ‘soil’
6	<i>ma-</i>	<i>make, makolo</i>	‘eggs’, ‘legs, feet’
7	<i>e-</i>	<i>etabo, eala</i>	‘book’, ‘camp’
8	<i>bi-/by-</i>	<i>bitabo</i>	‘books’
9	<i>N-</i>	<i>ngyoʔa</i>	‘snake’
	$\emptyset$ -	<i>óó, engwe</i>	‘chicken’, ‘leopard’
10	<i>N-</i>	<i>ngyoʔa</i>	‘snakes’
		<i>ndzikyē</i>	‘rivers’
	$\emptyset$ -	<i>óó, engwe</i>	‘chicken’, ‘leopards’
11	<i>lɔ-</i>	<i>lɔkolo, lɔkye</i>	‘mountain, ‘river’
	<i>lo-</i>	<i>losea, lobonga</i>	‘femininity’, ‘church’
	<i>lw-</i>	<i>lwala</i>	‘baldness’
12	<i>a-</i>	<i>anyoni, aɔma</i>	‘bird’, ‘short bat’
13	<i>to-/tw-</i>	<i>tonyoni, toɔma</i>	‘birds’, ‘short bats’
14	<i>bɔ-</i>	<i>bɔolo</i>	‘bigness’
	<i>bo-</i>	<i>bosoka</i>	‘goodness’
	<i>bw-</i>	<i>bwaha</i>	‘whiteness’
15	<i>ɔ-</i>	<i>ɔkolo</i>	‘legs, feet’

16	<i>a-</i>	<i>aboeke</i>	‘at the back’
		<i>anumba</i>	‘at home/by the house’
17	<i>o-</i>	<i>o-mesa</i>	‘on/towards the table’
		<i>o-lobonga</i>	‘on/to the church’
18	<i>m-</i>	<i>m-numba</i>	‘in the house’
		<i>m-lobonga</i>	‘in the church’
19	<i>i-</i>	<i>ikyo?a</i>	‘small snake’
	<i>y-</i>	<i>yaana</i>	‘small child’

Table 4: NOUN CLASSES IN BEMBE

Class 1 (*m-*) is reserved exclusively for nouns the referents of which are human. These can either be simple nouns (39a) or de-verbalised agentive ones (39b)

- (39) a. *mtu* ‘person’                      b. *myaki* ‘killer’  
*mwaana* ‘child’                              *msomi* ‘intellectual’  
*mboka* ‘neighbour’                        *mtendzi* ‘speaker’  
*mlomyana* ‘man’                              *mkochi* ‘seller’  
*mlome* ‘husband’

Class 1a ( $\emptyset$ ) consists of denominations for kinship and other relational terms for human referents, as exemplified in (40).

- (40) *òò* ‘grandmother’

Class 2 (*ba-*) contains the plural forms of class 1 nouns (41).

- (41) a. *batu* ‘people’                        b. *bayak-i* ‘killers’  
*baana* ‘children’                              *basom-i* ‘intellectuals’  
*baboka* ‘neighbours’                        *batendzi-i* ‘speakers’  
*balomyana* ‘men’                              *bakoch-i* ‘sellers’  
*balome* ‘husbands’

Class 2a contains the plural forms of kinship and relational terms for human referents. The only attested form is invariable from its singular counterpart.



(42)      òò            ‘grandmothers’

The classes 3 (*m-*) and 4 (*mi-*) contain a class of countable as well as uncountable nouns with no particular semantic coherence. In the case of countable nouns, class 3 (43a) is the singular and class 4 the plural (43b).

(43)	a.	<i>msea</i>	‘girl’	b.	<i>misea</i>	‘girls’
		<i>mmowe</i>	‘wind’		<i>miowe</i>	‘winds’
		<i>msoso</i>	‘spear’		<i>misoso</i>	‘spears’
		<i>mchwe</i>	‘head’		<i>michwe</i>	‘heads’
		<i>mshi</i>	‘blood’		<i>mishi</i>	‘bloods’
		<i>mtema</i>	‘heart’		<i>mitema</i>	‘hearts’
					<i>milema</i>	‘spirits’

Class 5 (*i-/hi-/chi-*) contains countable and uncountable nouns of no particular semantic coherence, (44a), qualitative nouns derived from stative verbs and noun-modifying elements, (44b), and infinitives, (44c).

(44)	a.	<i>ike</i>	‘egg’	b.	<i>ichunda</i>	‘bigness’
		<i>itete</i>	‘soil’		<i>ihoha</i>	‘lightness’
		<i>ichimo</i>	‘spear’			
		<i>hibwe</i>	‘stone’			
		<i>ito</i>	‘ear’			
		<i>chienyo</i>	‘tooth’			
		<i>ikolo</i>	‘sky’			
		<i>ilema</i>	‘spirit’			
	c.	<i>iyaka</i>	‘to kill’			
		<i>itenda</i>	‘to speak’			
		<i>iya</i>	‘to go’			

Class 6 (*ma-*) contains the plural forms of the classes 5, 11, 14 and 15. a high number of mass nouns besides countable nouns referring to abstract concepts.

- (45) *make* ‘eggs’  
*makye* ‘water’  
*mango* ‘weather’  
*mābe* ‘evils’  
*mato* ‘ears’  
*maenyo* ‘teeth’  
*makolo* ‘legs, feet’  
*māla* ‘rocks’  
*mabala* ‘fields’  
*mabola* ‘rains’

Classes 7 (*e-*) contains countable as well as mass nouns of no particular semantic coherence (46a), and singular augmentatives (46b) (see also section 2.1.2.).

- |         |               |          |    |               |                          |
|---------|---------------|----------|----|---------------|--------------------------|
| (46) a. | <i>etabo</i>  | ‘book’   | b. | <i>eana</i>   | ‘big child’ (pejorative) |
|         | <i>ebi</i>    | ‘door’   |    | <i>ebwa</i>   | ‘big dog’                |
|         | <i>esu</i>    | ‘forest’ |    | <i>ekyoʔa</i> | ‘big snake’              |
|         | <i>etanga</i> | ‘pond’   |    | <i>esea</i>   | ‘big girl’               |
|         | <i>esashi</i> | ‘herb’   |    |               |                          |

Class 8 (*bi-*) contains nouns of no particular semantic type (47a) and plural augmentatives (47b) (see also section 2.1.2.). In the case of human referents, the augmentative often induces a pejorative meaning.

- |         |                |           |    |                |                             |
|---------|----------------|-----------|----|----------------|-----------------------------|
| (47) a. | <i>bitabo</i>  | ‘books’   | b. | <i>byana</i>   | ‘big children’ (pejorative) |
|         | <i>bibi</i>    | ‘doors’   |    | <i>bisea</i>   | ‘big girls’ (pejorative)    |
|         | <i>bisu</i>    | ‘forests’ |    | <i>bikyoʔa</i> | ‘big snakes’                |
|         | <i>bitanga</i> | ‘ponds’   |    | <i>bibwa</i>   | ‘big dog’                   |
|         | <i>bisashi</i> | ‘herbs’   |    |                |                             |

Class 9 (*N-/Ø-*) contains countable as well as mass nouns, which do not seem to belong into one particular semantic category (48a), although the high frequency of terms designating animals is noteworthy (48b).

(48) a.	<i>ngyala</i>	‘hunger’	b.	<i>ngyoʔa</i>	‘snake’
	<i>ndeɔ</i>	‘banana’		<i>ngyoku</i>	‘elephant’
	<i>ndchwele</i>	‘hair’		<i>mbochi</i>	‘goat’
	<i>ngyála</i>	‘fingernail’		<i>óó</i>	‘chicken’
	<i>numba</i>	‘house’		<i>nyama</i>	‘animal, meat’
	<i>ndalo</i>	‘field’		<i>nguku</i>	‘hippopotamus’
	<i>mbola</i>	‘rain’			
	<i>sao</i>	‘bag’ (for men)			

Class 10 (N-/Ø-) contains the plural forms of class 9 and 11 nouns.

(49) a.	<i>ndeɔ</i>	‘bananas’	b.	<i>ngyoʔa</i>	‘snakes’
	<i>numba</i>	‘houses’		<i>ngyoku</i>	‘elephants’
	<i>ngyála</i>	‘fingernails’		<i>mbochi</i>	‘goats’
	<i>ndalo</i>	‘fields’		<i>óó</i>	‘chicken’
	<i>ndchwele</i>	‘hair’		<i>nyama</i>	‘animals’
	<i>fongolo</i>	‘keys’		<i>nguku</i>	‘hippopotami’
	<i>sao</i>	‘bag’ (for men)			
	<i>nenge</i>	‘babies, toddlers’			

Class 11 (lɔ-/lo-/lw-) contains common nouns of all semantic type (50a), including nouns denoting human referents, but also abstract nouns derived from nouns and verbs (50b).

(50) a.	<i>lofongolo</i>	‘key’	b.	<i>losea</i>	‘femininity’ (< <i>misea</i> ‘girl’)
	<i>lkye</i>	‘river’		<i>losongo</i>	‘advice’ (< <i>isongola</i> ‘to advise’)
	<i>lobola</i>	‘bee’		<i>lowambaka</i>	‘boyhood’ (< <i>mwambaka</i> ‘boy’)
	<i>lobula</i>	‘hail’		<i>lobonga</i>	‘church’
	<i>lokolo</i>	‘mountain’			
	<i>loso</i>	‘stomach’			
	<i>lochuele</i>	‘hair’			
	<i>lwala</i>	‘rock’			
	<i>lɔlɛnge</i>	‘baby, toddler’			

Class 12 (*a-*) contains nouns without any discernable semantic coherence (51a) and de-verbalised nouns (51b).

- |         |               |             |    |                  |                        |
|---------|---------------|-------------|----|------------------|------------------------|
| (51) a. | <i>anyoni</i> | ‘bird’      | b. | <i>atendechi</i> | ‘(manner of) speaking’ |
|         | <i>abwa</i>   | ‘dog’       |    | <i>ayakechi</i>  | ‘(manner of) killing’  |
|         | <i>acoma</i>  | ‘short bat’ |    | <i>alyechi</i>   | ‘(manner of) eating’   |
|         |               |             |    | <i>akolechi</i>  | ‘(manner of) buying’   |

Class 13 (*to-*) contains the plural forms of class 12 nouns. While the majority of the nouns in the sample designate animals, class 12 does not exclusively contain nominals designating animate (but non-human) referents. Consider the examples in (52).

- |      |                |          |
|------|----------------|----------|
| (52) | <i>tonyoni</i> | ‘birds’  |
|      | <i>tobwa</i>   | ‘dogs’   |
|      | <i>tocoma</i>  | ‘sticks’ |

Class 14 (*bo-*) contains mainly non-countable nouns (53a). It is also used to derive nominals referring to an abstract concept (53b) from stative verbs and noun-modifying elements, and finally to form plural diminutives (53c) (see also section 2.2.1).

- |         |               |                  |    |                  |                     |
|---------|---------------|------------------|----|------------------|---------------------|
| (53) a. | <i>bokyo</i>  | ‘money’          | b. | <i>boolo</i>     | ‘bigness’           |
|         | <i>bokya</i>  | ‘fire plough’    |    | <i>boilu</i>     | ‘blackness’         |
|         |               |                  |    | <i>boluachi</i>  | ‘sickness, illness’ |
|         |               |                  |    | <i>bobe</i>      | ‘badness, evilness’ |
|         |               |                  |    | <i>bolumyana</i> | ‘manhood, penis’    |
| c.      | <i>bobwa</i>  | ‘small dogs’     |    |                  |                     |
|         | <i>boana</i>  | ‘small children’ |    |                  |                     |
|         | <i>bokyoa</i> | ‘small snakes’   |    |                  |                     |

Class 15 (*o-/o-*) contains a high amount of nouns referring to parts of the body (54a). The prefix is also used to derive qualitative nouns from stative verb roots or noun-modifying elements (54b) (see also section 2.2.1) and infinitives (54c)



for assigning nouns to a certain noun class, given that human beings are almost universally grouped into class 1/2 irrespective of their natural gender (feminine or masculine). A second difference lies in the number of genders. While most languages are content with having two or three genders, the noun classes in Bembe are more numerous, and can be divided into regular class pairings, irregular class pairings and single, unpaired classes. These are illustrated in Table 5.

Class	Singular	Plural
1/2	<i>mtu</i> ‘person’	<i>batu</i> ‘people’
1a/2a	<i>òò</i> ‘grandmother’	<i>òò</i> ‘grandmothers’
3/4	<i>msoso</i> ‘spear’	<i>misoso</i> ‘spears’
5/6	<i>ike</i> ‘egg’	<i>make</i> ‘eggs’
7/8	<i>etabo</i> ‘book’	<i>bitabo</i> ‘books’
9/10	<i>ngyàla</i> ‘fingernail’	<i>ngyàla</i> ‘fingernails’
11/10	<i>lɔlɛnge</i> ‘baby, toddler’	<i>nenge</i> ‘babies, toddlers’
11/6	<i>lɔsoʔ</i> ‘stomach, belly’	<i>malɔsoʔ</i> ‘stomachs, bellies’
12/13	<i>anyoni</i> ‘bird’	<i>tonyoni</i> ‘birds’
14/6	<i>bɔbe</i> ‘evil’	<i>mãbe</i> ‘evils’
15/6	<i>ɔkolo</i> ‘leg, foot’	<i>makolo</i> ‘legs, feet’
	<i>ɔboo</i> ‘hand’	<i>maboo</i> ‘hands’

Table 5: NOUN-CLASS PAIRINGS

#### *Verb-to-noun derivation*

Verb-to-noun derivation is a productive nominalisation process in Bembe, which results in an agentive noun, or a common noun that describes either the action of a verb or the manner, way, or place of undertaking an action denoted by a verb. Nouns are derived by pre- and suffixation. A nominal stem is derived from a verbal base by attaching one of the suffixes *-i*, *-e*, *-echi*, *-o* or *-a*, and prefixing a corresponding class marker. The choice of class prefix is determined by the suffix of the nominal stem. Class 11 is used to transform verbs into common nouns which designate the action denoted by the verb. The markers of the classes 3, 4, 12, and 13 are prefixed to nouns that designate the manner or way of “undertaking” an action designated by the verb. Those of the classes 7 and 14 are used to form common nouns which designate the place of the action denoted by the verb.

*Agentive nouns (class 1 or 2 & final vowel -i)*

Agentive nouns are derived from verbs root by attaching the class 1 subject marker *m-* to create singular agentive nouns and class 2 subject marker *ba-* for plural ones (since agents are typically human), and by replacing the final vowel *-a* with an *-i*, as illustrated in (56).

(56)	<i>yak-a</i>	‘to kill’	>	<i>m-yak-i</i>	‘killer’
	<i>som-a</i>	‘to read’	>	<i>m-som-i</i>	‘reader’
	<i>tendz-a</i>	‘to speak’	>	<i>m-tendz-i</i>	‘speaker’
	<i>ly-a</i>	‘to eat’	>	<i>m-ly-i</i>	‘eater’
	<i>amb-a</i>	‘to work’	>	<i>m-amb-i</i>	‘worker’
	<i>sek-a</i>	‘to beg’	>	<i>m-sek-i</i>	‘beggar’
	<i>watelech-a</i>	‘to help’	>	<i>m-watelech-i</i>	‘helper’

- (57) a. *Ali a-ikyo-ly-a manga.*  
 1Ali 1SM-HAB-eat-FV a lot.  
 “Ali eats a lot.”
- b. *Iddi a-le mlyi (wa ngene).*  
 1Iddi 1SM-COP 1eater 1CONN goodness  
 “Iddi is a (good) eater.”
- c. *A-a-sek-a mlomyana bokyo.*  
 1SM-N.PST-beg-FV 1man 14money  
 “He has begged the man for money.”
- d. *Mtu a-le mseki.*  
 1person 1SM-COP 1beggar  
 “The person is a beggar.”

*Manner-of-action nouns (class 12 & -echi)*

In order to derive a noun which describes the manner of undertaking an action denoted by a verb, the nominal stem is derived from a verbal base by attaching the suffix *-echi*, and assigned to class 12 (by attaching the class prefix *a-*), as in (58a).

- (58) a. *i-tend-a* ‘to speak’ > *a-tend-echi* ‘manner of speaking’ [cl.12]  
*i-yak-a* ‘to kill’ > *a-yak-echi* ‘manner of killing’  
*i-ly-a* ‘to eat’ > *a-ly-echi* ‘manner of eating’  
*i-lela* ‘to cry’ > *a-lel-echi* ‘manner of crying’  
*i-lala* ‘to sleep’ > *a-lal-echi* ‘manner of sleeping’

The concord on modifiers and the agreement on verbs is identical to that usually induced by other nouns of the same class, as illustrated with de-verbalised nouns of class 12 in (59).

- (59) a. *Ake* *atend-echi* *ta-a-le* *a* *ngene*.  
12POSS.3SG 12speak-ING NEG-12SM-COP 12CONN goodness  
‘His (way of) speaking is not good.’
- b. *Ake* *anyat-echi* *ta-a-le* *a* *ngene*.  
12POSS.3SG 12walk-ING NEG-12SM-COP 12CONN goodness  
‘His (way of) walking is not good.’
- c. *Ake* *anyoni* *a-le* *a* *mmolo*.  
12POSS.3SG 12bird 12SM-COP 12CONN blackness  
‘His bird is black.’

*Place-of-action nouns* (class 7 or 14 & -elo)

In order to derive a noun which designates the place of an action denoted by a verb, the nominal stem is derived from a verbal base by attaching the class 7 (60a) or 14 (60b) class prefix *e-/ε-* or *bɔ-*, respectively, and the suffix *-elo* to the nominal stem.

- (60) a. *i-tend-a* ‘to speak’ > *e/ε-tend-elo* ‘place of speaking’  
*i-bak-a* ‘to butcher’ > *e/ε-bak-elo* ‘a butcher’s shop/place’  
*i-ly-a* ‘to eat’ > *e/ε-le-elo* ‘place where to eat’
- b. *i-tend-a* ‘to speak’ > *bɔ-tend-elo* ‘place of speaking’  
*i-bak-a* ‘to butcher’ > *bɔ-bak-elo* ‘a butcher’s shop/place’  
*i-ly-a* ‘to eat’ > *bɔ-le-elo* ‘place where to eat, restaurant’



*Common nouns* (class 8 *bi-* & passive extension *-w-*)

Some nouns are derived from verbs by prefixing the class 8 subject marker *bi-* to a verb and adding a passive extension, as illustrated in (61). (62) shows a Bembe proverb.

- (61) *i-sol-a* ‘to drink’ > *bi-sol-w-a* ‘drinks’ (Lit. ‘which is drunk’)  
*i-ly-a* ‘to eat’ > *bi-le(b)-w-a* ‘food’ (Lit. ‘which is eaten’)  
*i-tend-a* ‘to say, speak’ > *bi-tench-w-a* ‘words’ (Lit. ‘which is said’)

- (62) a. *Binwa bile bi-tendch-w-a. Bya-sha-a-tendch-w-a*  
 8word 8SM-COP 8SM-speak-PASS-FV. 8SM-NEG-PRES-speak-PASS-FV  
*ta-bi-le binwa .*  
 NEG-8SM-COP 8word  
 (Lit. “Words are said. What is not said, are not words.”)

*Noun-to-noun derivation*

Noun-to-noun derivation is a productive nominalisation process in Bembe, which results in the creation of locative nouns, diminutives and augmentatives. Further noun-formation processes are compounding and reduplication.

*Locatives*

As mentioned above, locatives are formed by attaching one of the three locative prefixes of the classes 16-18 to a whole nominal stem in pre-initial position, i.e. in a position preceding the nominal class prefix.

- (63) a. *m-n-umba*  
 18LOC-9-house  
 “in the house”  
 b. *\*m-umba*  
 18LOC-house  
 “(Int.: “in the house”)

The class 16 locative prefix *a-* expresses the state of being at a location, class 17 prefix *o-* the state of being on top of or moving towards a location, and class 18 *m-* the state of being contained in an enclosed space or the process of moving into one.

- (64) a. *Mw-ikyo-le* *a-lɔkye*  
 1PL-HAB-be 16LOC-11river  
 “We are (usually) at the river.”
- b. *Ta-to-y-e* *o-mboka*  
 NEG-2PL-go-FV 17LOC-9village  
 “Let us not go to the village!”
- c. *Na-mon-ine Ali* *m-numba.*  
 1SG-see-PST 1Ali 18LOC-9house  
 “I saw Ali in(side) the house.”

In so-called locative inversion it is the locative that appears in preverbal position and controls concord in the nominal phrase and agreement on the verb, as seen in (65). Note also that locative inversion in Bembe is only possible with the copula *i-ba* ‘to be’ (65a-b) and unaccusative verbs (65c-d).

- (65) a. *M-numba* *mu-le* *baana.*<sup>5</sup>  
 18-9house 18SM-COP 2child  
 “In the house are children.”
- b. *M-lobonga* *mu-le* *baana.*  
 18-11church 18SM-COP 2child  
 “In the church there are children.”
- c. *M-numba* *mwa-a-hingel-a* *batu.*  
 18-9numba 18SM-N.PST-enter-FV 2person  
 “Into the house entered (some) people.”
- d. \**O-lobonga* *o-y-a* *Iddi.*  
 17LOC-11church 17SM-go-FV 1Iddi  
 (Int. “Iddi has gone to church.”)

However, that locatives can in fact be logical subjects in conjunction with copular verbs is illustrated in (66). These are not inversion constructions but merely sentences with a locative as the subject. Given that locatives can function as subjects and objects shows

---

<sup>5</sup> Note that the present tense paradigm of the copula *i-ba* ‘to be’ is irregular. It is formed by prefixing a subject marker to the verb form *-le*, e.g. *nile* ‘I am’, *bale* ‘they are’.

that locatives are not PPs but DPs. Altogether, the locative seems to behave more like a nominal than a prepositional phrase (see also Chapter 4, section 4.3.6).

(66) a. *M-numba mu-le bosasa.*  
 18LOC-9house 18LOC-COP dirty

“In the house it is dirty.”

b. *O-lɔkolo o-le peo.*  
 17LOC-11mountain 17SM-COP cold

“On the mountain it is cold.”

An interesting use of the locative marker is given in (67), where it functions as a non-locative modifier, i.e. as a means of expressing genitive relations.

(67) *A-le beni m-benu i-wa-a-ly-a mleka?*  
 1SM-COP 1who 18LOC-PERS.2SG FOC-2REL-N.PST-eat-FV 3bean

(Lit. “It is who in you that has eaten beans?”)

“Who amongst/of you has eaten (the) beans?”

#### *Diminutives*

Diminutives are formed by attaching the class 19 prefix *i-* (*y-* before vowels) to singular noun roots and the class 14 prefix *bɔ-/bo-* (*bw-* before vowels) for plural ones. Some nouns can also be modified periphrastically by the use of *ishina/boshina* ‘small’.

- (68) a. *mw-ana* ‘child’ > *y-ana* ‘small child’  
*ba-ana* ‘children’ > *bw-ana* ‘small children’
- b. *a-bwa* ‘dog’ > *i-bwa, ishina ibwa* ‘small dog’  
*to-bwa* ‘dogs’ > *bo-bwa, boshina tobwa* ‘small dogs’
- c. *ngyoʔa* ‘snake’ > *i-kyoʔa* ‘small snake’  
*ngyoʔa* ‘snakes’ > *bo-kyoʔa* ‘small snakes’
- d. *msea* ‘girl’ > *i-sea* ‘small girl’  
*misea* ‘girls’ > *bo-sea* ‘small girls’

For singular nouns starting with a high front vowel, the use of *ishina* ‘small’ instead of the class 19 prefix *i-* is mandatory (possibly due to some phonotactic



(71) a.	<i>i-ke</i>	‘egg’	>	<i>eshina ike</i>	‘big egg’
				<i>*eke</i>	(Int. ‘big egg’)
	<i>ma-ke</i>	‘eggs’	>	<i>bishina make</i>	‘big eggs’
				<i>*bike</i>	(Int. ‘big eggs’)
b.	<i>hi-bwe</i>	‘stone’	>	<i>eshina hibwe,</i>	‘big stone’
				<i>*ebwe</i>	(Int. ‘big stone’)
	<i>ma-bwe</i>	‘stones’	>	<i>bishina mabwe,</i>	‘big stones’
				<i>*bibwe</i>	(Int. ‘big stones’)
c.	<i>a-bwa</i>	‘dog’	>	<i>eshina abwa, ebwa</i>	‘big dog’
	<i>to-bwa</i>	‘dogs’	>	<i>bishina tobwa, bibwa</i>	‘big dogs’

Just as other noun class prefixes, the prefixes used to form diminutives and augmentatives induce concord on other nominal elements and agreement on verbs. This is also valid for the lexical modifiers *ishina* & *boshina* ‘small’ and *eshina* & *bishina* ‘big’. Consider (72).

- (72) a. Bwetu bwana bo-le na ngyala.  
 14POSS.1PL 14child 14SM-COP with 9hunger  
 (Lit.: “Our small children are with hunger.”)  
 “Our small children are hungry.”
- b. *Lol-a!* Boshina *tobwa* bwa-a-chw-a *longe*.  
 Look-IMP | 14small 13dogs 14SM-N.PST-come-FV again  
 “Look! The small dogs have come again.”

#### *Nominalisation*

Some nouns indicating a quality are derived from a noun-modifying element or a stative verb by combining them with a prefix of the classes 14 *bo-* (73), 15 *ɔ-/o-* (74) or 5 *i-* (75). There exist cases in which the derivational source undergoes a phonological reduction in the formation process prior to prefixation, as in the first example in (73) (*-mmolo* > *-olo*).

- (73) *-mmolo* ‘big’ > *bɔ-olo* ‘bigness’ [cl.14]  
*-ammilu* ‘black’ > *bɔ-ilu* ‘blackness’  
*-luala* ‘sick’ > *bɔ-luachi* ‘sickness’  
*-soaka* ‘beautiful’ > *bo-soaka* ‘beauty, goodness’  
*-ena* ‘poor’ > *bɔ-ena* ‘poverty’
- (74) *-tota* ‘wet’ > *ɔ-tota* ‘wetness’ [cl.15]  
*-niʔa* ‘deep’ > *ɔ-niʔa* ‘depth’  
*-kónɔda* ‘thin’ > *ɔ-kɔnda* ‘thinness’  
*-le(y)a* ‘long, tall’ > *ɔ-le(y)a* ‘length’  
*-inyema* ‘heavy, thick’ > *ɔ-nyema* ‘heavyness, thickness’  
*-itakoloʔa* ‘wide’ > *ɔ-takoloʔa* ‘width’  
*ilónɔda* ‘to be difficult’ > *ɔ-lónɔda* ‘difficulty’  
*-ʔoma* ‘hard, strong’ > *ɔ-ʔoma* ‘hardness’  
*-bea* ‘ugly’ > *ɔ-bea* ‘ugliness’
- (75) *-chunda* ‘big’ > *i-chunda* ‘bigness’ [cl.5]  
*-hoha* ‘light’ > *i-hoha* ‘lightness’

It is often impossible to determine whether a noun indicating a quality is derived from a noun-modifying element or a verbal root, as they are often homophonous. Consider in this context the possible derivational sources of the noun *ɔ-lónɔda* ‘difficulty’ in (76), which could either be the stative verb *ilónɔda* ‘to be difficult’ (76a) or the noun-modifying element *lónɔda* ‘difficult’, which can be used attributively (76b) or predicatively (76c) by means of the so-called connective construction (see section 2.2.8).

- (76) a. *Mtu a-a-lónɔd-a.*  
1person 1SM-PRES-be.difficult-FV  
‘the person is difficult’
- b. *mtu wa lónɔda*  
1person 1CONN difficulty  
‘a difficult person’

c. *Ono mtu a-le wa lónda.*  
 1DEM.prox 1person 1SM-COP 1CONN difficulty  
 ‘this person is difficult’

Examples of how nouns which indicate a quality induce concord on modifiers and agreement on verbs are given in (77).

(77) a. *Bóolo bwa ngyoku bo-le bw-ilush-a bwoba.*  
 14bigness 14of 9elephant 14SM-COP 14SM-bring-FV 14fear  
 (Lit.: ‘The bigness of the elephant is brings fear.’)  
 ‘The big size of the elephant is frightening.’”

b. *Ichunda lya ngyoku le-le li-lush-a bwoba.*  
 5bigness 5of 9elephant 5SM-COP 5-bring-FV 14fear  
 (Lit.: ‘The bigness of the elephant is brings fear.’)  
 ‘The big size of the elephant is frightening.’”

c. *Iniya lya numba le-le lya ngene lumbaka*  
 5smallness 5of 9house 5SM-COP 5CONN goodness because  
*o-na-us-a lobelo.lobelo.*  
 15EXPL-POT-sweep-FV quickly.RED  
 (Lit.: ‘The smallness of the house is good because one can sweep quickly.’)  
 ‘The small size of the house is good because one can sweep quickly.’”

d. *Bosoka bwa maa ta-bo-na-bal-w-a.*  
 14goodness 14of 1my mother NEG-14SM-POT-count-PASS-FV  
 ‘My mother’s goodness/benevolence cannot be measured.’”

A small number of those roots that take the class 5 *i-* prefix can optionally also take the class 15 prefix *ɔ-/o-*, as illustrated in (78).

(78) *-nia* ‘small, narrow’ (> *i/ɔ-nia* ‘smallness’)  
*-fela* ‘short’ (> *i/ɔ-fela* ‘shortness’)

There are also cases of nouns indicating a quality that do not show any change from the derivational source, as in (79).

- (79) a. *soakelwa* ‘happy’ (> *soakelwa* ‘happiness’)  
*bweke* ‘sharp’ (> *bweke* ‘sharpness’)

- b. *mwele o-le bweke*  
 3knife 3SM-COP sharp  
 “the knife which is sharp”

In contrast to nouns indicating a quality, common nouns find their derivational source in verbs rather than noun-modifying concepts. Often a passive form of the verb is prefixed with the class 7 prefix *e-* or class 8 prefix *bi-*, as illustrated in (80a-b). In some cases, the verb also bears a causative extension besides a passive one, as shown in (80c). However, the described noun-formation process is not productive anymore.

- (80) a. *i-lea* ‘to eat’ > *bi-lewa* ‘s.th. that is eaten’ = ‘food’  
 b. *i-bola* ‘to rot’ > *e-bolwa* ‘s.th. that is rotten’ = ‘rotten food’  
 c. *i-botcha* ‘to cause to rot’ > *ebolechwa* ‘s.th. that has been caused to rot’  
 = ‘rotten food’

There exist examples of nouns in Bembe which are diachronically formed on the basis of (i) noun + relative clause, or (ii) noun + noun-modifying element constructions. Consider (81) and (82).

i. *Noun + relative*

- (81) *etanga ya-ni-á* > *Tangania*  
 7pond 7REL-to be deep-FV ‘Lake Tanganyika’  
 “a pond that is deep”

ii. *Noun + noun-modifying element*

- (82) a. *eto ea nyema* > *etonyema*  
 7thing 7CONN heaviness ‘something valuable’  
 “a heavy thing”



- b. *Etonyema e-ikyo-nyemi-w-a na mwene na eyo.*  
 7sth.valuable 7SM-HAB-value-PASS-FV by 1owner of 7it  
 (Lit. “Something valuable is valued by the owner of it.”)  
 “One learns to value something once one has it.”

*Reduplicated nouns*

Another noun formation strategy in Bembe is reduplication. Examples are given in (83).

- (83) *seuseu* ‘hiccup’  
*olaola* ‘hole dug by a mole’ (< *i-ola* ‘to dig’; cl.9)

**2.2.2 Personal pronouns**

Along with possessives, personal pronouns are the only elements in the nominal domain which overtly express the grammatical notion of person, besides noun class and hence number. This is however only valid for personal pronouns inside the noun classes 1/2. They are invariant lexical items, i.e. morphologically simple. Singular and plural forms are available, with two distinct forms for the third person pronouns depending on whether the referent is human or non-human. As Bembe does not have morphological case-marking, forms do not differ with regard to their function in the sentence, that is, whether they resemble subject pronouns (nominative case) or object pronouns (accusative case/dative case). Table 6 illustrates the available pronouns for class 1/2 nouns.

Person	Singular		Plural	
1	<i>ine</i>	‘I’	<i>bεchu</i>	‘we’
2	<i>obe</i>	‘you’	<i>benu</i>	‘you’
3	<i>εwe</i>	‘s/he, it’	<i>εbo</i>	‘they’

Table 6: PERSONAL PRONOUNS

For the remaining classes, there exist class-specific pronouns, which are formed by prefixing *ε-* and suffixing *-o* to a subject marker

Class	Pronoun	Class	Pronoun	Class	Pronoun
3	<i>εhɔ</i>	9	<i>εyɔ</i>	15	<i>εʔɔ</i>
4	<i>εyɔ</i>	10	<i>εchɔ</i>	16	<i>εhɔ</i>
5	<i>εlyɔ</i>	11	<i>εuɔ</i>	17	<i>εʔɔ</i>
6	<i>εmɔ</i>	12	<i>εʔɔ</i>	18	<i>εmɔ</i>
7	<i>εyɔ</i>	13	<i>εtɔ</i>	19	<i>εyɔ</i>
8	<i>εʔbɔ</i>	14	<i>εbɔ</i>		

Table 7: PERSONAL PRONOUNS (classes 3-19)

Personal pronouns are used less frequently than object and subject markers in Bembe, as arguments are usually expressed as subject and object markers in conjunction with verbs. The latter are attached to the verb and allow for sufficient identification of the referent due to their class-specific forms. If personal pronouns are used, it is either with a pure deictic function (e.g. while pointing at the referent), after propositions, or to emphasise the referent. Note that the fact that pronouns are used emphatically does not necessarily make them the focus of the utterance.

In coordinated noun phrases involving a pronoun and a lexical noun, the pronoun always precedes the lexical noun. In case the coordinated noun is not human, a comitative structure is preferred (84c). Although a coordinated structure is also grammatical, it is heavily degraded (84d).

(84) a. *Inε na Iddi twa-k-ile i-kel-a.*

I and 1Iddi 1PL-go-PST 5SM-fish-FV

“Iddi and I, we went fishing.”

b. *εwe na baana ba-k-ile o-mbala / o-esu.*

He and 2child 2SM-go-PST 17LOC-4forest / 17LOC-7forest

“He and the children went to the forest.”

c. *Na-k-ile na abwa.*

1SG-go-PST with 12dog

“I went with the dog.”

d. *??Inε na abwa ba-k-ile Goma.*

I and 12dog 2SM-go-PST Goma

“I and the dog went to Goma.”

### 2.2.3 Reflexive pronouns

There are two, mutually exclusive, reflexivisation strategies in Bembe, a verbal and a pronominal one. The verbal strategy consists of cliticising the reflexive marker *-hi-* to the verb, which must appear immediately to the left of the verb root, i.e. in the pre-radical position that is usually occupied by the object marker (see section 2.3.2.6 for details). The alternative is to use the lexical relative pronoun *imwene* ‘-self’ in object position, which must appear preceded by a personal pronoun, akin to reflexivisation in English, e.g. ‘him + self’ to form what I refer to as lexical reflexive. In contrast to the reflexive marker, lexical reflexives are added for emphatic reasons or to avoid ambiguity. Note that emphasis is not to be understood as, or equaled to, the notion of focus. The complete paradigm of lexical reflexives is illustrated by the examples in (85), while the examples in (86) illustrate the use of lexical reflexives in the sentence.

- (85) a. *Na-a-chic-a*      *ine imwene*.  
1SG-N.PST-hurt-FV I    self  
“I have hurt myself.”
- b. *Wa-a-chic-a*      *obe imwene*.  
2SG-N.PST-hurt-FV you self  
“You have hurt yourself.”
- c. *A-a-chic-a*      *ewe imwene*.  
1SM-N.PST-hurt-FV s/he self  
“S/he has hurt her/himself.”
- d. *Twa-a-chic-a*      *bɛchu babene*.  
1PL-N.PST-hurt-FV we    selves  
“We have hurt ourselves.”
- e. *Mwa-a-chic-a*      *benu babene*.  
2PL-N.PST-hurt-FV you    selves  
“You have hurt yourselves.”
- f. *Ba-a-chic-a*      *ɛbo babene*.  
3SM-N.PST-hurt-FV they selves  
“They have hurt themselves.”



14	<i>bw-</i>
15	<i>w-</i>
19	<i>y-</i>

Table 8: POSSESSIVE PREFIXES

POSS root	Person	Gloss
<i>-ane</i>	1SG	‘my’
<i>-obe</i>	2SG	‘your’
<i>-ake</i>	3SG	‘her/his/its’
<i>-etu</i>	1PL	‘our’
<i>-enu</i>	2PL	‘your’
<i>-abu</i>	3PL	‘their’

Table 9: POSSESSIVE ROOTS

The examples in (88) show that possessive pronouns can also appear in conjunction with deverbal nominals.

- (88) a. *Ake*            *atend-echi*    *ta-a-a-hikan-a*            *na*    *aetu*  
 12.POSS.3SG 12speak-ING NEG-12SM-PRES-sound-FV like 12POSS.1PL  
*(atend-echi).*

12speak-ING

(Lit. “His way of speaking does not sound like ours (speaking).”

“His language does not sound like ours.”

- b. *Ake*            *anyat-echi*    *ta-a-le*            *?a*            *ngene.*  
 12.POSS.3SG 12walking-ING NEG-12SM-COP 12CONN goodness  
 (Lit. “His walking is not of goodness.”)

“His way of walking is not good.”

## 2.2.5 Possessive connective construction

Another strategy of indicating a possessor relationship is by means of the connective. The connective results from the combination of a prefix identical to the subject marker, which agrees in noun class with the possessed NP, and a connective root (also associative marker) *-a*. It resembles in form the ‘NP-of-NP’ construction employed in

English possessor relations. The formation process of connective markers is exemplified in Fig. 4.

Noun class	Prefix		Connective root		Connective marker
7	<i>e-</i>	+	<i>-a</i>	=	<i>(?)ea</i>
11	<i>lo-</i>	+	<i>-a</i>	=	<i>lwa</i>
12	<i>(ʔ)a-</i>	+	<i>-a</i>	=	<i>(ʔ)a</i>

Fig. 4: FORMATION OF CONNECTIVE MARKERS

Agreement is with the possessed and not the possessor.

- (89) a. *bitabo bya mwana*  
 8book 8CONN 1child  
 (Lit. ‘the books of the child’)  
 “the child’s books”
- b. *lobonga lwa batu*  
 11church 11CONN 2man  
 “the church of the people”
- c. *A-le (ɔmo) wa wetu.*  
 1SM-COP (one) 1CONN our  
 (Lit. “S/he is (one) of our.”)  
 “He is one of us.”

Table 10 illustrates the forms of the connective marker throughout the 19 noun classes with examples. A glottal stop is sometimes added to connectives that start with vowels or semi-vowels if they follow a noun that ends in a vowel.

Class	Possessee	Connective marker	Gloss
1	<i>mwana</i>	<i>wa</i>	“the child of”
2	<i>baana</i>	<i>ba</i>	“the children of”
3	<i>mboka</i>	<i>wa</i>	“the village of”
4	<i>misea</i>	<i>ya</i>	“the girls of”
5	<i>iteté</i>	<i>lya</i>	“the soil of”
6	<i>make</i>	<i>ma</i>	“the eggs of”

7	<i>etabo</i>	<i>(?)ea</i>	“the book of”
8	<i>bitabo</i>	<i>bya</i>	“the book of”
9	<i>posu</i>	<i>ya</i>	“the axe of”
10	<i>ngyo?a</i>	<i>cha</i>	“the snake of”
11	<i>lobonga</i>	<i>lwa</i>	“the church of”
12	<i>anyoni</i>	<i>(?)a</i>	“the bird of”
13	<i>tonyoni</i>	<i>twa</i>	“the birds of”
14	<i>boolo</i>	<i>bwa</i>	“the bigness of”
15	<i>okolo</i>	<i>(?)wa</i>	“the leg of”
16	<i>amchango</i>	<i>wa</i>	“at the (wooden) door of”
17	<i>omboka</i>	<i>(?)wa</i>	“to the village of”
	<i>olobonga</i>	<i>lwa</i>	“to the church of”
	<i>olokye</i>	<i>lwa</i>	“to the river of”
18	<i>mchango</i>	<i>wa</i>	“in the door of”
	<i>mnumba</i>	<i>ya</i>	“in the house of”
	<i>msao</i>	<i>ya</i>	“in the bag of”
19	<i>ibwa</i>	<i>ya</i>	“the small dog of”

Table 10: CONNECTIVE MARKERS (POSSESSIVE MODIFICATION)

Note that the agreement behavior of connectives with locative nominals deviates from nominals of the remaining noun classes. Agreement of the connective marker with nominals bearing one of prefixes of the locative classes 16-18 is not driven by the locative class but instead by the noun class of the nominal. Thus the locative classes do not show any form of the connective marker particular to them. This is also shown in (90).

- (90) a. *Mo-y-e o-mboka wa Lega.*  
1PL-go-FV 17LOC-3village 3CONN Lega  
“Let us go to the village of the Lega.”
- b. *Ba-y-e o-lobonga lwa Paul.*  
2SM-go-FV 17LOC-11church 11CONN 1Paul  
“Let them go to Paul’s church.”

- c. *Ba-y-a o-numba ya Sophie.*  
 2SM-go-FV 17LOC-9house 9CONN 1Sophie  
 “They go to Sophie’s house.”

### 2.2.6 Demonstratives

Demonstratives are formed by combining one of the three available demonstrative roots with a class-specific adjectival concord marker. Of the three demonstrative forms, two are used exclusively for spatial relations and one for spatial relations and the referral to previously mentioned referents in the discourse. The usage of the demonstratives depends on the relative distance between the speaker and the referred-to object. Bembe speakers recognise three distances as being grammatically relevant: close to the speaker (proximal), close to the hearer (medial) and further away from both (distal). The root *-no* expresses proximity and is used for objects close to the speaker (English *this/these*) (91a-b), whereas the root *-lya* expresses distance and is used for objects distant to both speaker and addressee (English *that/those*) (91c-d). Medial demonstratives show class-specific forms which do not seem to follow a particular formation process (91e-f). Demonstratives always precede the nouns they modify.

- (91) a. *Ono mtu ta-a-a-sosany-a Philipp.*  
 1DEM.prox 1man NEG-1SM-PRES-resemble-FV 1Philipp  
 (Lit. “This man does not resemble Philipp.”)  
 “This man is different from Philipp.”
- b. *Bano batu ta-ba-a-sosany-a bechu.*  
 2DEM.prox 2man NEG-2SM-PRES-resemble-FV we  
 (Lit. “These people do not resemble we.”)  
 “These people are different from us.”
- c. *balya baana ba-a-mon-á Iddi.*  
 2DEM.dist 2child 2SM-N.PST-see-FV 1Iddi  
 “Those children have seen Iddi.”
- d. *Chilya numba chi-le cha ngene.*  
 10DEM.dist 10house 10SM-COP 10CONN goodness  
 “Those houses are good.”



- e. *Ao*                    *anyoni*    *ta-ʔa-a-sosany-a*                    *óó.*  
 12DEM.med    12birds    NEG-12SM-PRES-resemble-FV    9chicken  
 (Lit. “This bird does not resemble chicken.”)  
 “Yonder bird is different from chicken.”
- f. *Toto*                    *tɔnyoni*    *ta-twa-a-sosany-a*                    *óó.*  
 13DEM.med    13birds    NEG-13SM-PRES-resemble-FV    9chicken  
 (Lit. “These birds do not resemble chicken.”)  
 “Yonder birds are different from chicken.”

The demonstrative forms for each of the noun classes is summarised in Table 11.

Class	Proximal	Medial	Distal
1	<i>hono</i>	<i>hokyo</i>	<i>holya</i>
2	<i>bano</i>	<i>babo</i>	<i>balya</i>
3	<i>hono</i>	<i>hokyo</i>	<i>holya</i>
4	<i>heno</i>	<i>hekyo</i>	<i>helya</i>
5	<i>leno</i>	<i>lelo</i>	<i>lelya</i>
6	<i>mano</i>	<i>mamo</i>	<i>malya</i>
7	<i>ʔeno</i>	<i>ʔeʔyo</i>	<i>ʔelya</i>
8	<i>bino</i>	<i>bibyoy</i>	<i>bilya</i>
9	<i>heno</i>	<i>hekyo</i>	<i>helya</i>
10	<i>chino</i>	<i>chicho</i>	<i>chilya</i>
11	<i>lono</i>	<i>lolo</i>	<i>lolya</i>
12	<i>ano</i>	<i>ao</i>	<i>ʔalya</i>
13	<i>tono</i>	<i>toto</i>	<i>tolya</i>
14	<i>bono</i>	<i>bobo</i>	<i>bolya</i>
15	<i>ʔono</i>	<i>ʔoʔo</i>	<i>ʔolya</i>
16	<i>hano</i>	<i>hao</i>	<i>halya</i>
17	<i>ono</i>	<i>oo</i>	<i>olya</i>
18	<i>mno</i>	<i>mno</i>	<i>mlya</i>
19	<i>hino</i>	<i>hiyo</i>	<i>hilya</i>

Table 11: DEMONSTRATIVES

As regards their function in the sentence, demonstratives may be used as modifiers, always preceding the head noun they refer to (92a-b), or as pronouns, either as subject or object pronouns (92c-d), where they replace personal pronouns. Example (92e) shows that demonstratives may be focused in a cleft construction.

- (92) a. *Banu batu ba-le ba sona.*  
 2DEM.prox 2man 2SM-COP 2CONN badness  
 “These people are bad.”
- b. *Banu batu ba-a-son-á ba-a-achw-a lunge.*  
 2DEM.prox 2man 2REL-PRES-be.bad-FV 2SM-N.PST-come-FV again  
 (Lit. “These people who are bad have come again.”)  
 “These bad people have come again.”
- c. *Bino bi-le bya ngene.*  
 8DEM.prox 8SM-COP 8CONN goodness  
 “This is good.”
- d. *A-lo-som-a ?eno.*  
 1SM-PST-read-FV 7DEM.prox  
 “He read this/it (the book).”
- e. *Ba-le balya i-ba-a-mon-á Iddi ?ono olo?yelo.*  
 2SM-COP 2DEM.dist FOC-2REL-N.PST-see-FV 1Iddi 15DEM.prox  
 15morning.  
 “It is those (people) that have seen Iddi this morning.”

Though not found very frequently, two demonstratives can simultaneously precede and follow a noun, the function of which is to emphasise the referent.

- (93) a. *?ano abwa ano a-le a ngene.*  
 12DEM.prox 12dog 12DEM.prox 12SM-COP 12CONN goodness  
 (Lit. ‘This dog this is good.’)  
 “This dog is good.”

- b. *Chicho mesa chicho chi-le chane.*  
 10DEM.med 10table 10DEM.med 10SM-COP 10POSS.1SG  
 (Lit. ‘Yonder tables yonder are mine.’)  
 “Yonder tables are mine.”
- c. *Balya batu balya ba-mon-ine bechu.*  
 2DEM.dist 2person 2DEM.dist 2SM-see-PST we  
 (Lit. “Those people those saw we.”)  
 “Those people saw us.”

A reduplicated demonstrative of class 8 following the noun results in the creation of an adverb with the meaning ‘also, too’. All three kinds of demonstratives, i.e. proximal, medial and distal, can be used in this construction. Their frequency however varies, with the proximal demonstrative forms being by far the most productive and the distal ones the least, according to my language consultants.

- (94) *Ali bilya-bilya / bibyo-biyo / bino-bino a-soch-ile*  
 1Ali 8DEM.dist-RED / 8DEM.MED-RED / 8DEM-PROX-RED 1SM-drink-PST  
*maonde.*  
 6alcoholic drink  
 (Lit. “Ali that that/yonder yonder/this this drank the alcoholic drinks.”)  
 “Ali also drank the alcoholic drinks.”

### 2.2.7 Coordinator

Bembe has the Bantu-typical lexical coordinator *na*, which serves an array of different functions. It is used to express coordinative, comitative and instrumental relations but is also found as the head of the prepositional by-phrase in passives, and as the preposition used in comparisons. In addition, it is one of the two strategies available to express noun-modifying concepts in conjunction with an inanimate noun.

In this section I will focus on the coordinative, comitative, instrumental and prepositional function of the coordinator *na*, as illustrated in (95a-d). The remaining two functions, as exemplified in (95e-f), are discussed in sections 2.3.2.8 and 2.2.8 respectively.

- (95) a. *Eky na David ba-hech-ile o-lɔkolo.* [coordinative]  
 1Eky and 1David 2SM-climb-PST LOC-11mountain  
 “Eky and David climbed onto the mountain.”
- b. *Ali a-chu-le o-numba na nyakye.* [comitative]  
 1Ali 1SM-come-PST 17LOC-house with his.mother  
 “Ali came home with his mother.”
- c. *Ali a-kangoch-ile mchango na fongolo.* [instrumental]  
 Ali 1SM-open-PST 3door with 10key  
 “Ali opened the door with the keys.”
- d. *Chake ndcheule ta-cha-a-susany-a na tchetu.* [preposition]  
 10his 10hair NEG-10SM-PRES-be.alike-FV like ours  
 (Lit. “His hair is not alike like ours.”)  
 “His hair does not look like ours.”
- e. *A-lo-himb-w-a na wake mmɔɔ.* [passive]  
 1SM-PST-beat-PASS-FV by 1his/her 1brother  
 “S/he was beaten by his/her brother.”
- f. *A-le na ngyala.* [noun-modifying]  
 1SM-COP with 9hunger  
 (Lit. “S/he is with hungry.”)  
 “S/he is hungry.”

Used as conjunction, *na* conjoins two noun phrases, as in (96a), or it conjoins two sentences, as in (96b).

- (96) a. *Eky na David ba-hech-ile o-lɔkolo.*  
 1Eky and 1David 2SM-climb-PST 17-11mountain  
 “Eky and David climbed onto the mountain.”
- b. *John a-chu-le m-numba na a-l-ile kyenge yose.*  
 1John 1SM-come-PST 18LOC-9house and 1SM-eat-PST 9fufu 9all  
 “John came into the house and ate all the fufu.”

*Na* can coordinate two finite or non-finite verbs. Note that in such cases the subject or infinitival marker has to be repeated, as the examples in (97) illustrate.

(97) a. *A-l-ile*            *na*    *a-soch-ile*.  
 1SM-eat-PST            and    1SM-drink-PST  
 (Lit. ‘He ate and he drank.’)  
 ‘He ate and drank.’

b. *A-ond-ile*            *i-ly-a*            *na*    *i-sol-a*            (*i/n*)*nose*.  
 1SM-want-PST    5SM-eat-FV    and    5SM-drink-FV    only  
 (Lit. ‘He only wanted to eat and to drink.’)  
 ‘He only wanted to eat and to drink.’

Multiple instances of the coordinative *na* in one sentence can have different functions. Consider (98), in which the first *na* fulfills the coordinative, and the second one the comitative function.

(98) *Ali*    *na*    *David*    *ba-k-ile*            *o-soo*            *na*    *machimo*.  
 1Ali and 1David 2SM-go-PST    17LOC-market    with    6spear  
 ‘Ali and David went to the market with spears.’

Whenever proper names or common nouns are coordinated, agreement in coordinated nominal structures is resolved by means of resorting to the class 2 subject marker *ba-*.

(99) a. *Mlomyana*    *na*    *msea*    *ba-a-w-a*            *i-y-a*.  
 1man            and    3girl    2SM-N.PST-finish-FV    5SM-go-FV  
 (Lit. ‘The man and the girl have finished to go.’)  
 ‘The man and the girl have left already.’

b. *Ngyo?a*    *na*    *anyoni*    *ba-lwan-ine*.  
 9snake    and    12bird    2SM-fight-PST  
 ‘The snake and the bird fought.’

The examples in (100) show that the comitative function of the connective can be expressed with inanimate nouns.

- (100) a. *Ali a-k-ile o-lobonga na lyake ichimo.*  
 1Ali 1SM-go-PST 17LOC-11church with 5POSS 5spear  
 “Ali went to church with his spear.”
- b. *Ali a-och-ile na mbochi chibélé.*  
 1Ali 1SM-arrive-PST with 10goat 10two  
 “Ali arrived with two goats.”

As the following data illustrate, Bembe does not formally distinguish the instrumental and comitative function of the coordinator. Consider the contrast in (101a-b), in which the two functions are juxtaposed.

- (101) a. *Ali a-l-ile óó na make mabòò.*  
 1Ali 1SM-eat-PST 9chicken with 6POSS.3SG 6hand  
 “Ali ate the chicken with his hands.”
- b. *Ali a-l-ile óó na bikyombo.*  
 1Ali 1SM-eat-PST 9chicken with 8potatoe  
 “Ali ate the chicken with potatoes.”

Nor is there a difference between the coordinative and comitative use of *na* (102a-b).

- (102) a. *ya toola na ya mmilu*  
 9CONN redness and 9CONN blackness  
 “the red and black (one)”
- b. *Na-sambich-ile mleka wa toola na wa mmilu.*  
 1SG-mix-PST 3bean 3CONN redness and 3CONN blackness  
 “I mixed the red beans with the black ones.”

### 2.2.8 Noun modification

There are three ways to express the quality of a noun in Bembe, either by means of (a) a connective construction, (b) a relative construction with stative verbs, or (c) a coordinative construction.

(a) *Connective construction*

In the earlier introduced connective construction a connective marker combines with a noun modifying element, as illustrated in which results in the modification of a preceding noun, rather than indicating a possessor relationship.

NP	<i>wa</i>	<i>ngene</i>	“the good NP”
cl.1	1CONN	goodness	
NP	<i>bya</i>	<i>mmilo</i>	“the black NP”
cl.8	8CONN	blackness	

---

Fig. 5: NOMINAL MODIFICATION WITH CONNECTIVES

- (103) a. *mtu wa ngene*  
1person 1CONN goodness  
(Lit. “person of goodness”)  
“good person”
- b. *bitabo bya mmilo*  
8book 8CONN blackness  
(Lit. “books of blackness”)  
“black books”
- c. *mtu wa bolema*  
1person 1CONN 14stupidity  
(Lit. “person of stupidity”)  
“stupid person”
- d. *E-le nyama ya bwoba.*  
7SM-COP 9animal 9CONN 14fear  
(Lit. “It is an animal of fear.”)  
“It is a fearful animal.”

Connectives can appear independently of the noun they modify, as illustrated in (104).

- (104) a. *ya toola ya-a-chw-a.*  
9CONN redness 9SM-N.PST-come-FV  
(Lit. “of redness has come”)  
“The red one has come.” (understood: *nyama* “animal”)

- b. *ya hina ya-a-hon-a.*  
 9CONN blackness 9SM-N.PST-escape-FV  
 (Lit. “of blackness has escaped”)  
 “The black one has escaped.” (understood: *nyama* “animal”)

Class	Connective	Example	Gloss
1	<i>wa</i>	<i>mtu wa ngene</i>	‘person of goodness’
2	<i>ba</i>	<i>baana ba ngene</i>	‘children of goodness’
3	<i>wa</i>	<i>msea wa soaka</i>	‘girl of prettiness’
4	<i>ya</i>	<i>misea ya soaka</i>	‘girls of prettiness’
5	<i>lya</i>	<i>iteté lya ngene</i>	‘soil of goodness’
6	<i>ma</i>	<i>make ma mmolo</i>	‘eggs of bigness’
7	<i>ea (ya)</i>	<i>etabo ea mmilo</i>	‘book of blackness’
8	<i>bya</i>	<i>bitabo bya ngene</i>	‘books of goodness’
9	<i>ya</i>	<i>numba ya mmolo</i>	‘house of bigness’
10	<i>cha</i>	<i>numba cha mmolo</i>	‘houses of bigness’
11	<i>lwa</i>	<i>lochi lwa mmolo</i>	‘bag (female) of bigness’
12	<i>a</i>	<i>anyoni ?a lwala</i>	‘bird of sickness’
13	<i>twa</i>	<i>tonyoni twa lwala</i>	‘birds of sickness’
14	<i>bwa</i>	<i>bosoka bwa bope</i>	‘goodness of falsity’
15	<i>?wa</i>	<i>okolo ?wa lwala</i>	‘leg of unwellness’
19	<i>ya</i>	<i>yaana ya ngene</i>	‘small child of goodness’

Table 12: CONNECTIVE MARKERS (NOMINAL MODIFICATION)

(b) *Stative verbs*

A second adjectival modification strategy is the use of stative verbs. Stative verbs are verbs that describe a state of being of something rather than an action. In other languages this might be described by an adjective or expressed via some other grammatical device. In Bembe, stative verbs are used in their relativised form to serve as nominal modifier. This is illustrated in (105).

- (105) a. *Mleka wa-a-hol-á wa-a-kak-a*  
 3beans 3REL-N.PST-get.cold-FV 3SM-N.PST-go.bad-FV  
 (Lit. “Beans that have become cold have gone bad.”)  
 “The cold beans have gone bad.”



- b. *abwa a-a-leman-á*  
 12dog 12REL-PRES-be.disabled-FV  
 “dog that is disabled”  
 “disabled dog”
- c. *Ta-ba-ikyo-ly-a bilewa bya-a-kak-á.*  
 NEG-1SM-HAB-eat-FV 8food 8REL-N.PST-go.bad-FV  
 (Lit. “They do not (habitually) eat food that has gone bad.”)  
 “They do not eat spoiled food.”

In those cases in which the form of the stative verb is identical to that of a noun-modifying element (due to coalescence of the vowels of the subject and tense markers), the construction resembles the connective construction mentioned above. Consider the examples in (106).

- (106) a. *Balya batu ba-le ba sona.* (connective marker)  
 2DEM.dist 2person 2SM-COP 2CONN badness  
 “Those people are bad.”
- b. *Balya batu ba-a-son-a.* (stative verb)  
 2DEM.dist 2person 2SM-PRES-be.bad-FV  
 “Those people are bad.”
- c. *Ta-ba-ikyo-sangan-a na batu ba-a-son-á.* (rel. stative verb)  
 NEG.2SM-HAB-meet-FV with 2person 2REL-PRES-be.bad-FV  
 (Lit. “They do not see people that are bad.”)  
 “They (never) meet bad people.”

#### *Coordinative construction*

As already mentioned in section 2.2.7, a third and very productive strategy to form noun-modifying elements is to combine the lexical coordinator *na* with an inanimate noun. The resulting structure is identical to the connective construction, except for the fact that the coordinator *na* combines with an inanimate nominal that bears a class marker, as illustrated in (107).

- (107) a. *abwa a-lé na elonda.*  
 12dog 12SM-COP with 7injury  
 (Lit. “dog which is with injury”)  
 “injured dog”
- b. *baana ba-lé na ngiala*  
 2child 2SM-COP with 9hunger  
 (Lit. “child which is with hunger”)  
 “hungry child”
- c. *A-lé na msona.*  
 1SM-COP with 3resentment  
 “S/he who is resentful”
- d. *Baana ta-ba-lo-wat/so-a mabo makolo m-alé na ninga.*  
 2child NEG-2SM-PST-wash-FV their 6legs 6SM-COP with 9dirt  
 (Lit. “The children did not clean their feet which are with dirt.”)  
 “The children did not clean their dirty feet.”

Note that the *na* + nominal construction does not necessarily result in adjectival modification, as the example in (108) shows.

- (108) *Na-a-?w-a na peɔ.*  
 1SG-PRES-die-FV of ?cold  
 “I am dying of cold.”

### *Comparative*

The comparative is used to compare two things and to indicate the superiority, equality or inferiority of one of them in relation to the other and with respect to a certain quality. The comparative of superiority in Bembe is formed by using a stative verb followed by one of the verbs *iheta* or *ihema* (109a-b) or by using a lexical adjective (109c) followed by the infinitival form of the copula *ole*.

- (109) a. *Gloria a-a-le-a i-het-a Stone.*  
 1Gloria 1SM-PRES-be.tall/long-FV 5SM-surpass-FV 1Stone.  
 (Lit. “Gloria is tall to surpass Stone.”)  
 “Gloria is taller than Stone.”
- b. *Numba y-ake ya-a-chund-a i-hem-a y-ane.*  
 9house 9POSS-3SG 9SM-PRES-be.big-FV 5SM-surpass-FV 9POSS-1SG  
 (Lit. “His house is big to surpass mine.”)  
 “His house is bigger than mine.”
- c. *Nyaki wa Mary a-le mwanue o-le*  
 1mother 1CONN 1Mary 1SM-COP young 15SM-COP  
*chake achi.*  
 10POSS-3SG 10sisters.  
 (Lit. “Mother of Mary is young to be her sisters.”)  
 “Mary’s mother is younger than her sister.”

Note that one cannot leave out the verbs *iheta*, *ihema* or *ole*, as shown in (110).

- (110) a. *Lumbaka lwa éé eno numba ya chunda \*(i-het-a*  
 Because of what 9DEM.prox 9house 9CONN bigness 5SM-surpass-FV  
*chose).*  
 10others  
 (Int. “Why is this house bigger than the others?”)  
 “Why is this house bigger?”
- b. *Numba y-ake ya-a-chund-a \*(i-het-a chose).*  
 9house 9POSS-3SG 9SM-PRES-be.big-FV 5SM-surpass-FV 10others  
 (Int. “His house is bigger.”)

The comparative of equality in Bembe is formed with the help of the verb *ilengana* ‘to be equal’. When a certain quality is given by the context or mentioned in the discourse, it suffices to have the participants as joint subject of the verb (111a). Which quality they share to an equal extent is understood from the discourse. Note that the final vowel is always *-e* and not *-a*.

- (111) *Inε na Stone to-lengan-e*  
 I and 1Stone 1PL-be.equal-FV  
 (Lit. “I and Stone are equal.”)  
 “I am equal as Stone.” (with respect to the quality given by the context)

One can also choose a more specialised verb that expresses the quality to be assessed in the comparison directly, as illustrated in (112a-b). The examples in (112c-d) show that one can apply the comparative of equality to adverbs too. The element linking the two things to be compared, comparable to the preposition ‘like’ in English, is the word *ite*, which cannot be omitted.

- (112) a. *Stone a-a-le-a ite inε.*  
 1Stone 1SM-PERS-be.long-FV like PERS.1SG  
 (Lit. “Stone is long like me”)  
 “Stone is as tall as I.”
- b. *Goma ʔwa-a-le-a ite Bukavu.*  
 Goma 17SM-PERS-be.long-FV like Bukavu  
 (Lit. “Goma is long like Bukavu.”)  
 “Goma is as far as Bukavu.”
- c. *Tw-ikyo-ly-a lobelobelolo ite obe.*  
 2PL-HAB-eat-FV fast.RED like PERS.2PL  
 “We eat as fast as you.”
- d. *Ta-ba-na-te-a bya ngene ite Rose.*  
 NEG-2SM-POT-cook-FV 8CONN goodness like 1Rose  
 (Lit. “They cannot cook of good like Rose.”)  
 “They cannot cook as well as Rose.”

The comparative of inferiority in Bembe is also formed with the help of the verb *ilengana* ‘to be equal’. In order to express the fact that one thing is inferior to another with respect to a certain quality, one negates that one thing is equal to another with respect to a certain quality. Just like the comparative of equality, this is either done in a more general way without specifying the quality in question and which is highly context-dependent, as in (113a), or with a stative verb that expresses the quality to be

assessed in the comparison, as in (113b-c). Again, the element linking the two things to be compared is the word *ite*, which cannot be omitted.

- (113) a. *Gloria na Stone, ta-ba-a-lengy-e.*  
 1Gloria and 1Stone NEG-2SM-PRES-be.equal-FV  
 (Lit. “Gloria and Stone, they are not equal.”)  
 “Gloria is not as tall as Stone.”
- b. *Gloria ta-a-le-a ite Stone.*  
 1Gloria NEG-1SM-PRES-be.long-FV like 1Stone  
 (Lit. “Gloria is not long like Stone”)  
 “Gloria is not as tall as Stone.”
- c. *Henu numba ta-ya-a-chund-a ite yane.*  
 9DEM.prox 9house NEG-9SM-PRES-be.big-FV like 9POSS.2SG  
 “This house is not as big as yours.”

The comparatives of superiority, equality and inferiority are equally applicable to adverbs. This is shown in (114).

- (114) a. *John a-ikyo-tebet-a lobelolobelo i-het-a obe.*  
 1John 1SM-HAB-run-FV fast.RED 5SM-surpass-FV PERS.2SG  
 (Lit. “John (habitually) runs fast to surpass you.”)  
 “John (habitually) runs faster than you.”
- b. *John a-a-tebet-a ite obe.*  
 1John 1SM-PRES-run-FV like PERS.2SG  
 (Lit. “John runs like you.”)  
 “John runs as (fast as) you.”
- c. *John a-ikyo-tebet-a lobelolobelo ite obe.*  
 1John 1SM-HAB-run-FV fast.RED like PERS.2SG  
 (Lit. “John runs fast like you.”)  
 “John (usually) runs as fast as you.”
- d. *John ta-a-ikyo-tebet-a lobelolobelo ite obe.*  
 1John NEG-1SM-HAB-run-FV fast.RED like PERS.2SG  
 (Lit. “John does not know to run fast like you.”)  
 “John does not (usually) run as fast as you.”

### *Superlative*

The superlative is used to compare more than two things and to indicate the highest degree of quality exhibited by one of these things, as described by the adjective or adverb in question. There is no single form for the superlative in Bembe. Instead, it is formed by contrasting one member of a particular set of things or persons against all other members of that set using the comparative of superiority. Consider the examples in (115).

- (115) a. *Ano*            *ate*    *a-a-om-a*                    *i-het-a*            *twose*.  
12DEM.prox    12tree 12SM-PRES-be.hard-FV    5SM-surpass-FV 12all  
(Lit. “This tree is hard to surpass all.”)  
“This tree is the oldest.”
- b. *Bono*            *bo?i*    *bo-le*    *leshe*    *i-het-a*            *bonge*.  
14DEM.prox    14honey 14SM-COP    sweet    5SM-surpass-FV 14others  
(Lit. “This honey is sweet to surpass others.”)  
“This honey is the sweetest.”
- c. *numba*    *ya*            *eolo*            *m-mboka*    *i-het-a*            *chose*.  
9house    9CONN    7bigness    18-9village    5SM-surpass-FV 10all  
(Lit. ‘house of big in village to surpass all others’)  
“the biggest house in the village”
- d. *baana*    *bale*            *na*            *ngiala*            *i-hem-a*            *bose*.  
2child    2SM-COP    with    9hunger    5SM-surpass-FV 2all  
(Lit. “child with hunger to surpass all”)  
‘the hungriest child’

### **2.2.9 Numerals**

#### *Cardinal numbers*

Cardinal numbers are formed with the help of the connective markers. Only the cardinal numbers 1-5 in (116) can be prefixed when combined with other numbers, as shown in Table 13. However, if used alone, they do not take a prefix but must be used in a connective construction, as shown in (117).

- (116) *-mo* ‘one’  
*-bélé* ‘two’  
*-sato* ‘three’  
*-nachi* ‘four’  
*-táno* ‘five’

- (117) a. *batu ba sato*  
 2person 2CONN three  
 “three people”  
 b. *tochuba twa ʔiomi*  
 13cup 13CONN ten  
 “ten cups”

The remaining cardinal numbers, of which a selection is shown in Table 13, are invariable and always appear with a connective marker when modifying a nominal.

<i>n-toba</i> 9-six	‘six’	<i>mw-endzi</i> 3-seven	‘seven’
<i>e-nane</i> 7-eight	‘eight’	<i>ʔi-enda</i> 5-nine	‘nine’
<i>ʔi-omi</i> 5-ten	‘ten’	<i>ʔi-omi na e-mo</i> 5-ten with 7-one	‘eleven’
<i>ʔi-omi na bi-bele</i> 5-ten with 8-two	‘twelve’	<i>ʔi-omi na bi-sato</i> 5-ten with 8-three	‘thirteen’
<i>ʔi-omi na bi-nachi</i> 5-ten with 8-four	‘fourteen’	<i>ʔi-omi na bi-tano</i> 5-ten with 8-five	‘fifteen’
<i>ʔi-omi na n-doba</i> 5-ten with 9-six	‘sixteen’	<i>ʔi-omi na mw-endzi</i> 5-ten with 3-seven	‘seventeen’
<i>ʔi-omi na e-nane</i> 5-ten with 7-eight	‘eighteen’	<i>ʔi-omi na ʔi-enda</i> 5-ten with 5-nine	‘nineteen’
<i>ma-omi ma-bele</i> 6-ten 6-two	‘twenty’	<i>ma-omi ma-sato</i> 6-ten 6-three	‘thirty’
<i>ma-omi ma-nachi</i> 6-ten 6-four	‘forty’	<i>ma-omi ma-tano</i> 6-ten 6-five	‘fifty’

<i>ma-omi n-doba</i> 6-ten 9-six	‘sixty’	<i>ma-omi mw-endzi</i> 6-ten 3-seven	‘seventy’
<i>ma-omi e-nane</i> 6-ten 7-eight	‘eighty’	<i>ma-omi ?i-enda</i> 6-ten 5-nine	‘ninety’
<i>i-kana</i> 5-hundred	‘hundred’	<i>ma-kana ma-bele</i> 6-hundred 6-two	‘two hundred’

Table 13: CARDINAL NUMBERS

### *Ordinal numbers*

Ordinal numbers are formed by means of the connective construction in conjunction with a cardinal number. This is identical to the way noun modification qua connective markers is achieved. Ordinal number constructions thus display two connective markers as opposed to one in cardinal number constructions.

- (118) a. *mwana wa wa nachi*  
 1child 1CONN 1CONN four  
 (Lit.: “child of of four”)  
 “fourth child”

- b. *A-a-sol-a achuba ?a ?iomi ?a mmena.*  
 1SM-N.PST-drink-FV 12cup 12CONN ten 12CONN 3alcoholic.drink  
 (Lit. “Has drunk cup of ten of mmena.”)  
 “He has just drunk the tenth cup of mmena.”

### 2.2.10 Quantifiers

Quantifiers in Bembe come in two forms. They are either invariable or formed by combining a quantifier root with a class-specific prefix, the latter of which agrees in class with the noun it quantifies. There are no quantificational prefixes for the locative classes. The available quantificational prefixes are listed in Table 14.



Class	Prefix
1	<i>o-</i> / <i>w-</i>
2	<i>b-</i>
3	<i>wa-</i>
4	<i>ya-</i>
5	<i>lya-</i>
6	<i>ma-</i>
7	<i>ea-</i>
8	<i>bya-</i>
9	<i>ya-</i>
10	<i>cha-</i>
11	<i>lo-</i>
12	$\emptyset$ -
13	<i>to-</i>
14	<i>bo-</i>
15	<i>w-</i>
19	<i>y-</i>

Table 14: QUANTIFICATIONAL PREFIXES

*-ose* ‘every/all/whole’

The universal quantifier ‘every’ is formed by combining the quantificational root *-ose* and one of the prefixes listed in Table 14, based on the noun class of the nominal to be quantified.

- (119) a. *mtu*      *wose*  
           1person 1every  
           “every person”
- b. *añoni*    *∅ose*  
           12bird 12every  
           “every bird”

An alternative interpretation of *-ose* in combination with singular nominals is that of ‘whole’, under the condition that the referent to be quantified is discernable from the

discourse or the context allows for sufficient identification. Consider the contrast in (120).

- (120) *Sophie a-a-ly-a óó yose.*  
 1Sophie 1SM-N.PST-eat-FV 9chicken 9whole  
 a) “Sophie has eaten the whole chicken.” [of one available chicken]  
 b) “Sophie has eaten every chicken.” [of two or more available chicken]

When used with a plural nominal, *-ose* acquires the meaning of ‘all’, as in (121).

- (121) a. *ngyoʔa chose*  
 10snake 10every  
 “all snakes”  
 b. *baana bose*  
 2child 2every  
 “all children”

*-mo* ‘some’

Existential quantification is expressed by the quantifier root *-mo* ‘some (of)’, which combines with one of the 16 available class prefixes, the class of which is determined on the basis of the noun to be quantified. The resulting quantifier can be used with countable as well as uncountable or mass nouns, as illustrated in (122).

- (122) a. *omo mtu*  
 1some 1person  
 “some person”  
 b. *bamo batu*  
 2some 2person  
 “some people”  
 c. *mamo makye*  
 6some 6water  
 “some water”

- d. *hamo hato*  
 1some 16place  
 ‘some place’
- e. *mamo mata*  
 6some 6milk  
 “some milk”

*manga* / CONN+*manga* ‘many/much’

Large quantities of an entity are expressed with the quantifiers *manga* ‘many, several, much’ and *manga* + connective. *Manga* is used for countable nouns, as in (123a-b), while the connective construction is used for non-countable/mass nouns, as in (123c-d).

- (123) a. *batu manga*  
 2person many  
 “many people”
- b. *makambo manga*  
 6problems many  
 “many problems”
- c. *mshi wa manga*  
 3blood 3CONN many  
 “much blood”
- d. *bobekalo bwa manga*  
 14happiness 14CONN many  
 “much happiness”

An alternative strategy for expressing large quantities of entities is to use the relativised form of the stative verb *ibula* with the meaning ‘to be much/many’ instead of the quantifier with prefixed connective.

- (124) a. *makye ma-a-bul-á*  
 6water 6REL-PRES-be.much-FV  
 (Lit. “water that is much”)  
 “much water”

- b. *mbolá cha-a-bul-á*  
 10bee 10REL-PRES-be.many-FV  
 (Lit. “bees that are many”)  
 “many bees”
- c. *lobula lwa-a-bul-á*  
 11hail 11REL-PRES-be.much-FV  
 (Lit. “hail that is much”)  
 “much hail”

*aniha* ‘few/little’

Small quantities of an entity are expressed with a connective construction involving the quantifier *aniha*. As opposed to quantification of large quantities, no distinction is made on the basis of the nominal to be quantified being countable or non-countable. This is illustrated in (125).

- (125) a. *machu ma aniha*  
 6clouds 6CONN few  
 (Lit. “clouds of few”)  
 “few clouds”
- b. *nyama cha aniha*  
 10animals 10CONN few  
 (Lit. “animals of few”)  
 “few animals”
- c. *makye ma aniha*  
 6water 6CONN few  
 (Lit. “water of few”)  
 “little water”
- d. *mseke wa aniha*  
 3sand 3CONN few  
 (Lit. “sand of little”)  
 “little sand”

However, note that when a connective is combined with a countable nominal of a singular class, it acquires the meaning of ‘thin, skinny, tiny, small’.<sup>6</sup> This is shown in (126).

- (126) a. *ichu lya niha*  
 5cloud 5CONN few  
 (Lit. “cloud of few”)  
 “small/tiny cloud”
- b. *nyama ya niha*  
 9animal 9CONN few  
 (Lit. “animal of few”)  
 “thin animal”
- c. *mwambaka wa niha*  
 1boy 1CONN few  
 (Lit. “boy of few”)  
 “thin/skinny boy”

An alternative to the connective strategy is to use the negated form of the relativised verb *ibula*, which originally means ‘to be many’. Again, countable *and* non-countable nouns can be used with this construction.

- (127) a. *machu ma-a-sa-bul-á*  
 6cloud 6REL-NEG-PRES-be.a.lot-FV  
 (Lit. “clouds that are not a lot/many”)  
 “few clouds”
- b. *bawambaka ba-sa-a-bul-á*  
 2boy 2REL-NEG-PRES-be.a.lot-FV  
 (Lit. “boys that are not a lot/many”)  
 “few boys”

---

<sup>6</sup> An exception to this are non-countable nouns pertaining to the singular class 3 (such as in (125d)), in which case *aniha* does not acquire the meaning of ‘few’ but retains the meaning of ‘little’.

- c. *makye ma-sa-a-bul-á*  
 6water 6REL-NEG-PRES-be.a.lot-FV  
 (Lit. “water that is not a lot/much”)  
 “little water”
- d. *mseke wa-sa-a-bul-á*  
 3sand 3REL-NEG-PRES-be.a.lot-FV  
 (Lit. “sand that is not a lot/much”)  
 “little sand”

Yet another alternative is to use a copular construction. Thus, (127b) (repeated here as (128a)) can also be expressed as in (128b).

- (128) a. *bawambaka ba-sa-a-bul-á*  
 2boy 2REL-NEG-PRES-be.a.lot-fv  
 (Lit. “boys that are not a lot/many”)  
 “few boys”
- b. *bawambaka ba-shi-l-é manga*  
 2boy 2REL-NEG-COP-FV many  
 (Lit. “boys that are not a lot/many”)  
 “few boys”

Note that *manga* can also be used as degree adverbs/intensifier ‘very’, as illustrated in (129) (see also section 3.4.6.).

- (129) a. *A-a-feel-a manga.*  
 1SM-PRES-be.short-FV very  
 (Lit. “S/he is short very.”)  
 “S/he is very short.”
- b. *A-a-lɛ-a manga.*  
 1SM-PRES-be.tall-FV very  
 (Lit. “She is tall very.”)  
 “S/he is very tall.”

The attested nominal, verbal, possessive, pronominal, demonstrative and quantificational prefixes discussed in this section are summarised in Table 15.

Class	Noun	Possessive	Demonstrative	Connective	Quantificational
1	<i>m-/mw-</i>	<i>w-</i>	<i>ho-</i>	<i>wa-</i>	<i>o- / w-</i>
1a	∅-	?	?	?	?
2	<i>ba-</i>	<i>b-</i>	<i>ba-</i>	<i>ba-</i>	<i>b-</i>
2a	∅-/ <i>ba-</i>	?	?	?	?
3	<i>m-/mw-</i>	<i>w-</i>	<i>ho-</i>	<i>wa-</i>	<i>wa-</i>
4	<i>mi-/my-</i>	<i>y-</i>	<i>he-</i>	<i>ya-</i>	<i>ya-</i>
5	<i>hi-/i-</i>	<i>ly-</i>	<i>le-</i>	<i>la-</i>	<i>lya-</i>
6	<i>ma-</i>	<i>m-</i>	<i>ma-</i>	<i>ma-</i>	<i>ma-</i>
7	<i>e-</i>	<i>e-</i>	<i>ʔe-</i>	<i>ea-/ya-</i>	<i>ea-</i>
8	<i>bi-/by-</i>	<i>by-</i>	<i>bi-</i>	<i>bya-</i>	<i>bya-</i>
9	<i>N-/∅-</i>	<i>y-</i>	<i>ya-</i>	<i>ya-</i>	<i>ya-</i>
10	<i>N-/∅-</i>	<i>tʃ-</i>	<i>chi-</i>	<i>cha-</i>	<i>cha-</i>
11	<i>lɔ-/lo-/lw-</i>	<i>lw-</i>	<i>lo-</i>	<i>lwa-</i>	<i>lo-</i>
12	<i>a-</i>	<i>a-</i>	<i>a-</i>	<i>a-/ʔa-</i>	∅-
13	<i>to-/tw-</i>	<i>tw-</i>	<i>to-</i>	<i>twa-</i>	<i>to-</i>
14	<i>bɔ-/bo-/bw-</i>	<i>bw-</i>	<i>bo-</i>	<i>bwa-</i>	<i>bo-</i>
15	<i>ɔ-</i>	<i>w-</i>	<i>ʔo-</i>	<i>ʔw-</i>	<i>w-</i>
16	<i>a-</i>	-	<i>ha-</i>	-	-
17	<i>o-</i>	-	<i>ʔo-</i>	-	-
18	<i>m-</i>	-	<i>m-</i>	-	-
19	<i>i-/y-</i>	<i>y-</i>	<i>hi-</i>	<i>(h)ya-</i>	<i>y-</i>

Table 15: AGREEING PREFIXES IN THE NOMINAL DOMAIN

### 2.2.11 Prepositions

The number of ‘real’ prepositions in Bembe is restricted to three, i.e. *bila* ‘without’, *na* ‘with, by, like’ and *asamb(ela)* ‘between’. This may in part be due to the alternative strategies the language offers to its speakers to express spatial concepts. As we have already seen, speakers of Bembe can either choose the synthetic strategy of combining a noun stem with a locative marker, as in *m-numba* ‘in the house’, or they make use of the analytic strategies of either (a) combining a locational noun with a connective marker, as in *mbele ya mtu* ‘in front of a person’, or (b) combining a locational noun with the

preposition *na*, as in *anuma na mchango* ‘behind the door’. The use of the prepositions and the alternative strategies are discussed below.

*bila* ‘without’

There exists no preposition with the meaning ‘without’ in Bembe. Instead, my language informants claim that the Swahili loanword *bila* ‘without’ is used, as in (130a). Alternatively, the absence of something or someone is simply expressed with the help of negated verbs or copular constructions, as in (130b-c) respectively.

- (130) a. *Na-k-ile o-lol-a óó bila Iddi.*  
 1SG-go-PST 15SM-visit-FV grandma without 1Iddi  
 “I went to visit grandma without Iddi.”
- b. *Na-k-ile o-lol-a óó o-shi-b-ilé na Iddi.*  
 1SG-go-PST 15SM-visit-FV 1grandma IREL-NEG-COP-PST with 1Iddi  
 (Lit. “I went to visit grandma who was not with Iddi.”)  
 “I went to visit grandma without Iddi.”
- c. *Na-ond-a bilewa bya-s-a-long-w-á.*  
 1SG-want-FV 8food 8REL-NEG-PRES-salt-PASS-FV  
 (Lit. “I want food that is not been salted.”)  
 “I want my food without (any) salt.”

*na* ‘with, by, like’

The word *na* has multiple meanings, depending on its use (see also sections 2.2.7 and 2.2.8). In instrumental constructions it has the meaning ‘with’, as in (131a), just as it does in comitative constructions (131b). When used in passivisation contexts, it has the meaning ‘by’ and identifies the demoted agent of the passive, as in (131c). Furthermore, it is used in conjunction with the verb of comparison *isusanya* ‘to be like’, which it always follows (131d).

- (131) a. *na mwele* (instrumental)  
 with 3knife  
 “with a/the knife”



- b. *na abwa* (comitative)  
 with 12dog  
 “with a/the dog”
- c. *i-mon-w-a na mtu* (by-phrase)  
 5SM-see-PASS-FV by 1person  
 “to be seen by someone”
- d. *Chake ndcheule ta-cha-susany-a na tchetu.* (comparative)  
 10his 10hair NEG-10SM-be.alike-FV like 10ours  
 (Lit. “His hair is not alike with ours.”)  
 “His hair does not look like ours.”

*m-* ‘in, into’

There exists no preposition in Bembe in order to express the meaning of being inside or moving into a(n) (enclosed) space. Instead, the class-18 locative marker *m-* is exclusively used for this purpose. This is illustrated in the examples in (132).

- (132) a. *A-le m-Bukavu.*  
 1SM-COP 18LOC-Bukavu  
 “S/he is in Bukavu.”
- b. *Be-a mwele m-saho!*  
 Put-FV 3knife 18LOC-9bag  
 “Put the knife into the bag!”

*amboka* ‘out(side) of’

The word for describing the state of being outside or outside of an enclosed area is *amboka*. It is the grammaticalised form of the combination of a locative class marker *a-* and the nominal *mboka* ‘village’, literally meaning ‘at the village’. In Bembe, not being at one’s home is equaled to being somewhere else in the village *amboka*, and hence ‘outside’. When used as a preposition, *amboka* is always followed by a class 16 connective marker (133a-b). It can also be used as an adverbial of location (133c).

- (133) a. *a-mboka a numba*  
 16LOC-9village 16CONN 9house  
 “outside of the house”

b. *To-b-ile a-mboka a lobonga.*

1PL-COP-PST 16LOC-9village 16CONN 11church

(“We were outside of church.”)

“We were outside of the church.”

c. *Bilewa bi-le a-mboka.*

8food 8SM-COP 16LOC-9village

“The food is outside.”

*aboeke/oboeke, anuma* ‘behind’

*Aboeke/oboeke* and *anuma* express the state of being behind an entity or a person. If used as a preposition, it is always followed by *na*, as in (134a). It can also be used an adverbial of location, as in (134b), however, without *na*.

(134) a. *Mtu a-a-himan-a anuma na mchango.*

1person 1SM-PERS-stand-FV behind with 3door

(Lit. “Person stands behind with door.”)

“The person is standing behind the door.”

b. *A-a-y-a a/o-boeke.*

1SM-N.PST-go-FV 16/17LOC-behind

(Lit. “S/he has gone to/on behind.”)<sup>7</sup>

“S/he has gone to the toilet.”

*mbele* ‘in front of’

The state of being in front of an entity or a person is expressed with the preposition *mbele* and a class 9 connection marker *ya-*. Examples are given in (135).

(135) a. *A-le mbele ya numba*

1SM-COP 9front 9CONN 9house.

“She is in front of the house.”

b. *Ta-o-himan-e mbele ya mtu*

NEG-2SG-stand-FV 9front 9CONN 1person

“You do not stand in front of a person.”

---

<sup>7</sup> The use of *-boeke* ‘behind’ to designate the toilet originates in the fact that the Babembe originally had their toilets behind their houses.

*ose, mmanda* ‘under/below’

The state of being under an entity or a person is expressed with the preposition *mmanda* in connection with the preposition *na*.

- (136) a. *Na-m-mon-ine mmanda na ate.*  
1SG-1OM-see-PST under of 12tree  
“I saw him under a tree earlier.”
- b. *Lond-a mmanda na bisashi.*  
search-FV under of 8leaf  
“Search under the leaves!”

*abanda na* ‘on(to)/above’

The state of being on or over, or moving onto something/someone is expressed by the prepositional phrase *abanda na* or the class 17 locative marker *o-*, as shown in (137).

- (137) a. *Lond-a abanda na numba.*  
search-FV on of 9house  
“Search on the house!”
- b. *Eky na David ba-hech-ile o-lɔkolo.*  
1Eky and 1David 2SM-climb-PST 17LOC-11mountain  
“Eky and David climbed on(to) the mountain.”

*asamb(el)a* ‘between’

In order to express the state of being (in)between two entities or persons, the preposition *asamba* (or its variant *asambela*) is used.

- (138) a. *asamb(el)a makolo*  
between 6leg  
‘between the legs’
- b. *asamb(el)a bisambo*  
between 8friend  
‘between friends’

‘to, towards’ (Eng.)

There exists no preposition in Bembe that indicates that something or someone is moving to(wards) a certain place. Instead, solely the class 17 locative marker *o-* is prefixed to common nouns for this purpose. However, locative prefix *o-* cannot be attached to proper place names. This is shown in (139).

- (139) a. *To-y-e o-numba!*  
2PL-go-FV 17LOC-9house  
“Let us go to the house!”
- b. *To-y-e (\*o-)Goma!*  
2PL-go-FV 17LOC-Goma  
“Let us go to Goma!”

‘from’ (Eng.)

In order to indicate that something or someone is moving from a certain place, Bembe speakers combine the verb *ichwa* ‘to come’ with the applicative marker *-el-*, which results in *ichwela* ‘to come from’. This is illustrated in (140).

- (140) a. *Mmohe/mnyaka wa-a-chw-el-a olya.*  
3wind 3SM-come-APPL-FV 17LOC-DEM.dist  
“The wind comes from there.”
- b. *Ba-a-chw-el-a Bukavu.*  
2SM-PRES-come-APPL-FV Bukavu  
“They come from Bukavu.” (though not in the sense of living there)

‘at’ (Eng.)

Bembe does not feature a preposition with the meaning of being in the immediate vicinity of a place. As (141) shows, this function is instead assumed exclusively by the class 16 locative prefix *a-*.

- (141) a. *Gloria a-le a-mtachi/-tanganya.*  
1Gloria 1SM-COP 16LOC-3shore/9lake  
“Gloria is at the shore/lake.”

- b. *Mwiwa wane a-a-himan-a a-mchango*  
 1nephew 1POSS.1SG 1SM-PRES-stand-FV 16LOC-3door  
 “My nephew stands at the door.”

*obanda na* ‘about’

The preposition with the meaning ‘about’ – in the sense of ‘being concerned with’ – can be rendered in Bembe with *obanda na* (142).

- (142) a. *Etabo e-le obanda na msea.*  
 7book 7SM-COP about with 3girl  
 “The book is about a girl.”
- b. *Na-a-ond-a ni-many-e obanda na bita.*  
 1SG-PRES-want-FV 1SG-learn.about-FV about with war  
 “I want to know more about the war.”

*aonga/mmonga na* ‘next to’

The concept of being in or moving into a position immediately next to somebody or something is expressed in Bembe either by the prepositional phrase *aonga na* or *mmonga na*.

- (143) a. *Iddi a-le aonga na numba.*  
 1Iddi 1SM-COP next to 9house  
 “Iddi is next to the house.”
- b. *Ba-ikyo-hiyan-a mmonga na lokye.*  
 2SM-HAB-live-FV next to 11river  
 “They live next to a river.”

The preposition *mmonga* also conveys the meaning of being in the immediate vicinity of a place, as the gloss of the example (144) illustrates.

- (144) *Ba-ikyo-hiyan-a mmonga na lokye.*  
 2SM-HAB-live-FV next to 11river  
 “They live close to the river.” (lit. ‘near’)

The different strategies used to express spatial concepts in Bembe are listed in Table 16.

Strategy	Example	Gloss
1) Preposition	<i>bila ewe</i>	‘without him’
	<i>asamb(el)a bisambo</i>	‘between friends’
	<i>na kyenge</i>	‘with fufu’
	<i>na ewe</i>	‘by him’
	<i>na mmɔlɔ</i>	‘like a brother’
2) Locative prefix	<i>m-numba</i>	‘in the house’
3) Locational + CONN	<i>amboka a numba</i>	‘out(side) of the house’
	<i>mbele ya mtu</i>	‘in front of a person’
4) Locational + <i>na</i>	<i>ose/mmanda na</i>	‘under/below’
	<i>abanda na</i>	‘on/above’
	<i>boeke/anuma na</i>	‘behind’
	<i>obanda na</i>	‘about’
	<i>aonga/mmonga na</i>	‘next to, beside, close to’

Table 16: EXPRESSION OF SPATIAL CONCEPTS

### 2.2.12 Interrogative pronouns

Like in many other Bantu languages, in Bembe there is a constraint on having no focused elements in preverbal position. Since Wh-phrases are said to be inherently focused, or rather non-referential, which makes them non-topical, this restriction naturally extends to Wh-phrases. The only element that is allowed to appear in preverbal position is the Wh-question word *lumbaka lwa éé* ‘why’. I limit myself to presenting a list of the most frequent interrogative pronouns in Bembe below, and postpone the discussion of the distributional facts of Wh-words to section 2.4.8.

- (145) *beni* ‘who’  
*éé* ‘what’  
*ole(hé)* ‘where’  
*bile(hé)* ‘how’  
 NP + *beni* ‘which’  
 SM+ *-nga* ‘how many’  
*lumbaka lwa éé* ‘why’  
*lole(hé)/manga beni* ‘when’

### 2.2.13 Conjunctions

Besides the earlier discussed *na* ‘and’ (see section 2.2.7), there is a range of other lexical items which are used for con-/disjoining clauses, a selection of which is presented below.

*lumbaka* ‘because’

The equivalent to the conjunction ‘because’ in Bembe is *lumbaka*. It is usually placed between two clauses (146a-b) but can also appear in sentence-initial position, as in (146c).

- (146) a. *Na-a-lokw-a lumbaka Mary a-a-y-a.*  
 1SG-PRES-be.sad-FV because 1Mary 1SM-PRES-go-FV  
 “I am saddened because Mary has gone.”
- b. *Ta-a-na-himan-a lumbaka a-a-lwal-a / a-le*  
 NEG-1SM-POT-stand.up-FV because 1SM-PRES-to.be.sick-FV / 1SM-COP  
*mlwachi.*  
 1sick  
 “He cannot stand up because he is sick.”
- c. *Lumbaka Chris a-a-y-a, i-twa-lep-a manga.*  
 because 1Chris 1SM-N.PST-go-FV, FUTII-1PL-pay-FV many/much  
 “Because Chris has gone, we will pay a lot.”

*nge* / *-na-* ‘if’

The lexical complementiser *nge* ‘if’, used to introduce a conditional clause, appears in conjunction with the bound morpheme *-na-*, which is affixed to the verb (see section 2.4.4). *Nge* is usually placed between two clauses but can also appear in sentence-initial position. The following examples illustrate the usage of the lexical complementiser *nge* and the bound morpheme *-na-*.

- (147) a. *Mleka u-na-b-ile wa ngene nge Iddi*  
3beans 3SM-POT-COP-PST 3CONN goodness if 1Iddi  
*a-na-ho-te-ile.*  
1SM-POT-3OM-cook-PST  
“The beans would have been good if Iddi had cooked them.”
- b. *Nge Iddi a-na-te-ile mleka, u-na-b-ile wa*  
If 1Iddi 1SM-POT-cook-PST 3beans 3SM-POT-COP-PST 3CONN  
*ngene.*  
goodness  
“If Iddi had cooked the beans, they would have been good.”
- c. *Iddi a-na-te-ile mleka, u-na-b-ile wa ngene.*  
1Iddi 1SM-POT-cook-PST 3beans 3SM-POT-COP-PST 3CONN goodness  
“If Iddi had cooked the beans, they would have been good.”

The lexical complementiser *nge* is also used in case of two or more alternatives, comparable to the usage of *whether* in English, as illustrated in (148).

- (148) a. *Shi-iky-e nge i-ba-chw-a.*  
1SG-know-FV if FUTII-2SM-come-FV  
“I do not know whether they will come (or not).”
- b. *Bya-a-changan-a nge a-a-y-a Goma ao Bokavu.*  
8SM-PRES-depend-FV if 1SM-PRES-go-FV Goma or Bukavu  
“It depends on whether he goes to Goma or Bukavu.”



*ao/ama/hange* ‘or’

There are two different forms equivalent to the English coordinating disjunction ‘or’, *ao*, *ama* (both come from Swahili) and *hange*. Of these three, the former two are used more frequently, arguably because *hange* also means ‘maybe’ (cf. section 2.3.4).

- (149) a. *Hange o-na-y-a*                      *ao/ama o-na-shikal-a*.  
Either 2SG-POT-go-FV or 2SG-POT-stay-FV  
“You can stay or you can leave.”
- b. *Newcastle, ?w-ikyo-lo-a*                      *hange/ao/ama ?w-iky-otal-a*  
Newcastle 15EXPL-HAB-rain-FV or 15EXPL-HAB-shine-FV  
EXPL-HAB-shine-FV  
“Newcastle, it either rains or shines”

*shiéta* ‘but’

The adversative conjunction ‘but’ is expressed with the lexical conjunction *shiéta*.

- (150) a. *O-na-shikal-a*                      *shiéta ta-o-olw-a*                      *o-tend-a*  
2SG-POT-stay-FV but NEG-2SG.OM-must-FV 15SM-speak-FV  
“You can stay but you must not talk.”
- b. *Ngvo?a ya-chik-ile*                      *Iddi shiéta ta-ya-m-yak-ile*.  
9snake 9SM-bite-PST 1Iddi but NEG-9SM-1OM-kill-PST  
“The snake bit Iddi but (it) did not kill him.”

*mbele* ‘before’

The temporal conjunction ‘before’ is expressed by *mbele*.

- (151) a. *Mbele a-tend-e*                      *yose elya a-shi-b-ile*                      *a-a-w-a*  
before 1SM-say-FV 7all 7thing 1SM-S.FUT-COP-PST 1SM-N.PST-finish-FV  
*o-y-a*.  
15SM-go-FV  
(Lit. “Before said all thing, she was finished to go.”)  
“Before he could say anything, she had (already) left.”

- b. *Mbele ya ʔi-ingel-a m-numba, soʔ-a mobe*  
 Before 9CONN 5SM-enter-FV 18LOC-9house clean-FV 6POSS.2SG  
*makolo.*<sup>8</sup>  
 6foot  
 (Lit.: “Before of to enter into the house, clean/wash your feet!”)  
 “Before you enter the house, clean your feet!”
- c. *Soʔ-a mobe makolo mbele ya ʔi-ingel-a*  
 clean-IMP 6POSS.2SG 6foot before 9CONN 5SM-enter-FV  
*m-numba.*  
 18LOC-9house  
 (Lit.: “Clean/wash your feet before of to enter into the house!”)  
 “Clean your feet before you enter the house!”

*anuma + na* ‘after’

The subordinating temporal conjunction ‘after’ is expressed primarily by the combination of the words *anuma* ‘behind’ and *na* ‘with’. The verb introducing *anuma na* appears always in its infinitive form (152a-b). A succession of events can alternatively be expressed by the contrasting use of different tenses, i.e. far past vs. near past. This is exemplified in the examples (152c-d).

- (152) a. *Anuma na ɛwe i-hingel-a m-yomba, batu bose*  
 Behind with s/he 5SM-enter-FV 18LOC-9room 2person 2all  
*ba-a-naholech-a.*  
 2SM-PRES-silence-FV  
 (Lit. “Behind with she to enter into the room, people all silenced.”)  
 “After she entered the room, everybody silenced.”
- b. *Anuma na ɛwe i-lya, ba-na-y-a Goma.*  
 Behind with s/he 5SM-eat-FV 2SM-POT-go-FV Goma  
 (Lit. “Behind with s/he to eat, could go Goma.”)  
 “After s/he has eaten, they will go to Goma.”

---

8 One may object to the classification of *mbele* as a subordinating conjunction and rather treat it as a preposition given that it appears with a connective marker and in front of what could be taken to be a deverbal nominal. However, note that deverbal nouns are derived as shown in (58), i.e. by prefixing the class 12 marker *a-* and suffixing *-echi* to a verb root. The verbs in (151b-c), however, are merely infinitives, and I hence treat *mbele* as a subordinating conjunction.

- c. *A-et-ile a-hingen-e m-yomba, batu bose*  
 1SM-do-PST 1SM-enter-FV 18LOC-9room 2person 2all  
*ba-a-naholech-a.*  
 2SM-PRES-silence-FV  
 (Lit. “He did enter into the room, people all silenced.”)  
 “After s/he entered the room, everybody silenced.”
- d. *Ba-b-ile ba-na-ly-a, ba-na-y-a Goma.*  
 2SM-do-PST 2SM-F.PST-eat-FV 2SM-POT-go-FV Goma  
 (Lit. “They did eat, they would go Goma.”)  
 “After they ate breakfast, they went to Goma.”

*bikyanga* ‘while’

The temporal conjunction ‘while’ is expressed by *bikyanga* (lit. ‘time’).

- (153) *Ba-holo o-m-chw-el-a bikyanga bi-a-b-ilé*  
 2SM-come 15SM-1OM-come-APPL-FV 8time 8REL-1SM-COP-PST  
*mo-ly-a.*  
 PROG-eat-FV  
 (Lit. “They came to come for him time (he) was eating.”)  
 “They came for him while he was eating.”

*Lo-/Lw- + -chw* ‘when’

The subordinating temporal conjunction ‘when’ is expressed with the verb *-ichwa* ‘to come’, which is invariably prefixed with the prefix (*lo-* (*lw-*)).

- (154) a. *Lw-a-ch-u-le o-mboka/m-numba, batu*  
 When-1SM-come-PST 16LOC-9village /18LOC-9house 2person  
*bose ba-b-ile ba-a-w-a o-y-a.*  
 2all 2SM-COP-PST 2SM-N.PST-finish-FV 15SM-go-FV  
 (Lit. “When s/he came to the village/house, all people were finished to go.”)  
 “When s/he came home, everybody had already left.”

- b. *Lo-shi-kyol-e lokyé, bikyanga bi-ob-a bya-a-w-a*  
 When-S.FUT-rise-FV 1river 8time 8SM-will-FV 8SM-N.PST-finish-FV  
*o-hetan-a.*  
 15SM-pass-FV  
 (Lit. “When rises river, time will have finished to pass.”)  
 “When the river rises, it will already be too late.”

*-naand* ‘although’

A concessive clause is a subordinate clause which refers to a state-of-affairs different from the one described in the matrix clause. To introduce a concessive clause in Bembe, the conjunction *-naand* is used, to which a subject marker and the final vowel *-e* or the past tense marker *-ile* must be affixed, as in (155). Despite the subject marker and verbal suffixes, it is not clear to me whether *-naand* is a verbal root.

- (155) a. *Ba-naand-e o-b-a ta-ba-ikyo-to-a lobelo,*  
 2SM-although-FV 15SM-COP-FV NEG-2SM-HAB-return.home-FV early  
*ta-ba-nabash-a i-kol-a numba.*  
 NEG-2SM-afford-FV 5SM-buy-FV 9house  
 (Lit. “Although to be (they) do (usually) not return home early, (they) to buy house.”)  
 “Although they never come home early, they cannot afford to buy a house.”
- b. *A-naand-ile o-b-a a sona, a-mon-ile mseá.*  
 1SM-although-PST 15SM-COP-FV 1CONN ugliness 1SM-see-PST 3girl  
 “Although he was ugly, he found (lit.: saw) a girl.”
- c. *O-naand-e o-b-a mkakya, a-lo-m-tendz-a.*  
 3SM-although-FV 15SM-COP-FV 3contempt 1SM-PST-1OM-speak-FV  
 “Despite being contemptuous, she spoke to him.”
- d. *O-naand-e o-b-a mkakya, a-lo-hol-el-a*  
 3SM-although-FV 15SM-COP-FV 3contempt 1SM-PST-come-APPL-FV  
*i-m-tendz-a.*<sup>9</sup>  
 5SM-1OM-talk-FV  
 (Lit. “Although to be contempt, came to talk.”)  
 “Despite being contemptuous, she was able to talk to him.”

9 *i-hol-el-a* ‘to be able to’ (applicative) < *i-hol-a* ‘to come’ (transitive).

The discussed conjunctions are summarised in Table 17.

Conjunction	Gloss	
<i>na</i>	‘and’	(coordinate clause)
<i>ao, hange</i>	‘or’	(coordinate clause)
<i>shiéta</i>	‘but’	(adversative clause)
<i>nge</i>	‘if’	(conditional clause)
<i>lumbaka</i>	‘because’	(reason clause)
<i>mbele</i>	‘before’	(temporal clause)
<i>anuma na</i>	‘after’	(temporal clause)
<i>bikyanga</i>	‘while’	(temporal clause)
<i>naande</i>	‘although’	(concessive clause)

Table 17: CONJUNCTIONS

#### 2.2.14 Word order in the nominal phrase

This section illustrates the order of the elements in the Bembe nominal phrase.

Demonstrative > Nominal

- (156) *ono mlome*  
 1DEM.prox 1husband  
 “this husband”

Possessive <> Nominal

- (157) a. *wane mlome*  
 1POSS.1SG 1husband  
 “my husband”
- b. *mlome wane*  
 1husband 1POSS.1SG  
 “my husband”

Nominal > Noun-modifying element

- (158) *batu ba ngene*  
2person 2CONN goodness  
“good people”

Nominal > Noun-modifying element (Numeral)

- (159) *batu ba sato*  
2person 2CONN three  
“three people”

Nominal > Noun-modifying element < > Noun-modifying element (Numeral)

- (160) a. *batu ba sato ba ngene*  
2person 2CONN three 2CONN goodness  
“three good people”  
b. *batu ba ngene ba sato*  
2person 2CONN goodness 2CONN three  
“three good people”

Demonstrative > Possessive < > Nominal

- (161) a. *ono wane < > mlome*  
1DEM.prox 1my 1husband  
“this my husband”  
b. *ono mlome < > wane*  
1DEM.prox 1husband 1my  
“this my husband”

Demonstrative > Nominal > Noun-modifying element < > Noun-modifying element  
(Numeral)

- (162) a. *balya batu ba sato ba ngene*  
2DEM.DIST 2person 2CONN three 2CONN goodness  
“these three good people”  
b. *balya batu ba ngene ba sato*  
2DEM.DIST 2person 2CONN goodness 2CONN three  
“these three good people”

Demonstrative > Possessive <> Nominal > Noun-modifying element <> Noun-modifying element (Numeral)

(163) a. *Bano bane baana ba sato ba ngene*  
 2DEM.prox 2POSS.1SG 2child 2CONN three 2CONN goodness  
*ta-ba-b-ile heho.*  
 NEG-2SM-COP-PST there  
 (Lit. “These my children of three of goodness were not there.”)  
 “These my three children were not there”

b. *bano baana bane ba sato ta-ba-b-ile heho*  
 2DEM.prox 2child 2POSS.1SG 2CONN three NEG-2SM-COP-PST there  
 (Lit. “These my children of three of goodness were not there.”)  
 “These my three children were not there.”

Based on the above data, the order of elements in the Bembe nominal phrase is as illustrated in (164).

(164) Demonstrative > Possessive <> Nominal > Noun-modifying element <>  
 Noun-modifying element (Numeral)

## 2.3 Verbs and verbal categories

### 2.3.1 The structure of the Bembe verb

The verb stem in Bembe is made up of a verbal base (VB), which itself consists of a verbal root and possible extensions, and a final vowel (FV). Depending on the language in question, the final vowel is claimed to serve an array of different functions (cf. Nurse 2008: 260). While there exist a number of views on the purpose and function of the final vowel, the general consensus is that it is needed for phonotactic reasons, namely to ensure the well-formedness of syllable structures according to the Bembe-typical CV syllable.

The verb stem combined with an object marker (OM) is referred to as macro-stem, evidence for which is “generally phonological in nature” (Marlo 2008: 2) and the existence of which is primarily motivated by being implicated in tonal processes (Bickmore 2000; Clements & Goldsmith 1984; Hyman & Ngunga 1994; Kisseberth 1984; Kisseberth & Odden 2003; Mutaka 1994; Myers 1987, 1988; Odden 1987, 1988 amongst others).

Preceding the macro-stem, there are a number of verbal slots reserved for prefixes that encode negation, subject arguments and tense/aspect/mood (TAM). The structure of the Bembe verb comes close to the formal verb template for Proto-Bantu set out in Meeussen (1967: 108), on which much of the analysis and terminology is based. The verbal structure is illustrated in Table 18.

Pre-pre-initial	Pre-initial	Initial	Post-initial	TAM	Macrostem			
					OM	Stem		
						VB		FV
						Root	Ext	

Table 18: THE STRUCTURE OF THE BEMBE VERB

The inflected Bembe verb shows ten distinct verbal slots, as shown in Table 19, of which only those categories occupying the initial, radical and final position are obligatory (165a). However, there are examples in the data set which show that up to ten verbal slots can be occupied simulatenously, as illustrated in the example (165b).



- (165) a. *Ba-kol-ile.*  
 2SM-buy-PST  
 “They bought.” (in the sense of “They did the buying”.)
- b. *bilewa i-bi-ba-sha-lo-m-kol-el-ak-a*  
 8food FOC-8REL-2SM-NEG-PST-1OM-buy-APPL-DUR-FV  
 “the food which they have never bought on his behalf”

The ordering of the verbal slots is illustrated in Table 19. (Note that Tables 18 and 19 overlap in that the pre-radical to final slots in Table 19 correspond to the slots shown under macrostem in Table 18).

Pre-pre-initial	Pre-initial	Initial	Post-initial	TAM	Pre-radical	Radical	Post-radical	Pre-final	Final
-----------------	-------------	---------	--------------	-----	-------------	---------	--------------	-----------	-------

Table 19: BEMBE VERBAL SLOTS

### 2.3.2 Verbal categories

#### *Focus marker*

A prefix *i-*, which is invariant in form, appears preverbally in cleft constructions. That it must occupy a position different from the pre-initial slot, can be seen from its simultaneous appearance with the relative marker in (166). The function of a cleft construction is to emphasise the new-information or narrow-focus reading of a certain element by extracting it, which leads me to analyse the *i-* marker as some sort of focus marker.<sup>10</sup> Alternatively, it could be analysed as the pronominal head of the relative clause (provided the relative marker is analysed as grammatical agreement morpheme).

- (166) a. *E-le etabo i-ya-som-ilé baana.*  
 7SM-COP 7book FOC-7REL-read-PST 2child  
 “It is a book that the children read (not a newspaper).”
- b. *A-le Eky i-wa-a-chw-á m-lobonga.*  
 1SM-COP 1Eky FOC-1REL-N.PST-come-FV 18-11church  
 “It is Eky who has come into the church (not Rose).”

<sup>10</sup> The prefix *i-* in Bembe cleft constructions is reminiscent of the prefix *i-* which is also attested in Kĩĩtharaka (E54) spoken in Kenya, and which Abels & Muriungi (2008) treat as focus marker.

- c. *Ba-b-ile baana i-ba-koch-ile bitabo.*  
 2SM-COP-PST 2child FOC-2REL-buy-FV 8book  
 “It was the children who bought books (not the adults).”

However, I do not rule out the possibility that the *i-* marker could be the (grammaticalised) pronominal head of the relative clause. More data is needed on this issue. Note that the focus marker can also appear on other elements in the sentence. The function the focus marker serves in the following examples is less than clear at this point.

- (167) a. *Eno i-computa i ya ngene.*  
 9DEM.prox FOC-9computer ? 9CONN goodness  
 “This is the computer that is good.”
- b. *Banu i-baana ba-a-kol-á bilewa.*  
 2DEM.prox ?-2child 2SM-N.PST-buy-FV 8food.  
 “These are the children that have bought (some) food.”
- c. *Banu ba-le baana i-ba-a-kol-á.*  
 2DEM.prox 2SM-COP 2child ?-2REL-N.PST-buy-FV  
 “These are the children that have bought (some) food.”

### 2.3.2.1 Pre-initial position

#### *Relative marker*

Relative clauses take a relative marker corresponding in class with that of the head noun. They always precede the subject marker in object relative clauses with a non-overt subject (Type 1 object relatives; see section 2.4.2, ex. (284)). In object relatives with overt subjects (Type 2 relatives) and subject relative clauses, the relative marker is the only argument marker that surfaces.

Class	Relative marker
1SG	<i>o-/wa-</i>
2SG	<i>o-/wa-</i>
1	<i>o-/wa-</i>
1PL	<i>to-/twa-</i>

2PL	<i>mu-/mwa-</i>
2	<i>ba-</i>
3	<i>o-/wa-</i>
4	<i>he-</i>
5	<i>le-</i>
6	<i>ma-</i>
7	<i>(?)e-</i>
8	<i>bi-</i>
9	<i>ya-</i>
10	<i>cha-/chi-</i>
11	<i>lo-</i>
12	<i>ʔa-</i>
13	<i>to-</i>
14	<i>bo-</i>
15	<i>ʔo-/ʔw-</i>
16	<i>ha-</i>
17	<i>o-/ʔw-</i>
18	<i>m-/mw-</i>
19	<i>hi-/i-</i>

Table 20: RELATIVE MARKERS

- (168) a. *mtu wa-yak-ilé ngyoʔa*  
 1person 1REL-kill-PST 9snake  
 “the person who killed the snake”
- b. *bitabo bya-a-som-á lubelolubelo Iddi*  
 8book 8REL-N.PST-read-FV slow.RED 1Iddi  
 “the books that Iddi has read slowly”
- c. *bitabo bya-ba-a-som-á lubelolubelo*  
 8book 8REL-2SM-N.PST-read-FV slow.RED  
 “the books that they have read slowly”

*Negation marker (Neg1)*

There are two morphemes associated with negation in Bembe, the use of which depends on whether the negated verb is used in a subordinate or a non-subordinate sentence. In

non-subordinate contexts, negation is expressed in the form of the negation marker *ta-*, which occupies a position immediately preceding the subject marker, as in (169). Subordinate negation is expressed in the post-initial position and will be discussed in the corresponding section below.

- (169) a. *Ta-ba-a-yak-a*            *ngyoʔa*.  
 NEG-2SM-N.PST-kill-FV 9snake  
 “They have not killed the snake.”
- b. *Ta-ba-a-hi-chic-a*.  
 NEG-2SM-N.PST-REF-hurt-FV  
 “They have not hurt themselves.”
- c. *Ta-a-na-ile*.  
 NEG-1SM-POT-PST  
 “S/he could not.”

The situation is slightly different for 1<sup>st</sup> person singular subjects, which show the portmanteau allomorphs *sha-/shi-* in negated structures, while the remaining persons keep the usual negation marker *ta-* and mark grammatical person separately, as shown in (170).

- (170) a. *Shi-iky-e*            *mtu*.  
 NEG.1SG-know-FV 1person  
 “I do not know anyone.”
- b. *Ta-o-iky-e*            *mtu*.  
 NEG-2SG-know-FV 1person  
 “You do not know anyone.”
- c. *Ta-a-iky-e*            *mtu*.  
 NEG-1SM-know-FV 1person  
 “S/he does not know anyone.”
- d. *Ta-to-iky-e*            *mtu*.  
 NEG-1PL-know-FV 1person  
 “We do not know anyone.”

- e. *Ta-mo-iky-e mtu.*  
 NEG-2PL-know-FV 1person  
 “You do not know anyone.”
- f. *Ta-ba-iky-e mtu.*  
 NEG-2SM-know-FV 1person  
 “They do not know anyone.”

The negative portmanteau morpheme *sha-* seems to be subject to allomorphy as a result of vowel harmony. In case it precedes a high front vowel, it is realised as *shi-*, while being realised as *sha-* elsewhere.

- (171) a. *Shi-shi-kemb-e.*  
 NEG.1SG-S.FUT-sing-FV  
 “I will not sing.”
- b. *Shi-ikyo-kemb-a.*  
 NEG.1SG-HAB-sing-FV  
 “I (usually) do not sing.”
- c. *Sha-koch-ile bilewa.*  
 NEG.1SG-buy-PST 8food  
 “I did not buy (any) food.”
- d. *Sha-a-məm-a.*  
 NEG.1SG-N.PST-shrink-FV  
 “I have not shrunk.”
- e. *Sha-a-bàmb-a.*  
 NEG.1SG-N.PST-bet-FV  
 “I have not bet.”

The same rules apply to copular negation: the negation marker always precedes the subject marker and shows the allomorphy described above. This is illustrated in (172).

- (172) a. *Ni-le.* > *Shi-le.*  
 1SG-COP NEG.1SG-COP  
 “I am.” “I am not.”

- b. *A-le.* > *Ta-le.*  
 1SM-COP NEG-1SM-COP  
 “S/he is.” “S/he is not.”
- c. *Ba-b-ile.* > *Ta-ba-b-ile*  
 2SM-COP-PST NEG-2SM-COP-PST  
 “They were not.”

### 2.3.2.2 Initial position

The initial verb position can be occupied either by a subject marker, an infinitival or an expletive marker.

#### *Subject marker*

Subjects in Bembe are marked on the verb via a subject prefix. All inflected verb forms obligatorily bear a subject marker (or prefix), with the exception of infinitive and imperative verb forms. Bembe has 19 noun classes of which only the classes 1 and 2 are inflected for number and grammatical person, while the remaining ones are inflected for number only.

Class	Person	Subject marker
	1SG	<i>na-/ni-</i>
	2SG	<i>o-/wa-</i>
1	3SG	<i>a-</i>
	1PL	<i>to-/tw-</i>
	2PL	<i>mu-/mwa-</i>
2	3PL	<i>ba-</i>
3		<i>o-/wa-</i>
4		<i>ya-</i>
5		<i>lya-</i>
6		<i>ma-</i>
7		<i>ea-/ya-</i>
8		<i>bya-</i>
9		<i>ya-</i>
10		<i>cha-</i>
11		<i>lwa-</i>

12		<i>a-</i>
13		<i>twa-</i>
14		<i>bwa-</i>
15		<i>ʔo-/ʔwa-</i>
16		<i>a-</i>
17		<i>ʔo-/ʔwa-</i>
18		<i>mwa-</i>
19		<i>hi-</i>

Table 21: BEMBE SUBJECT MARKERS

Subject markers are subject to the rules of vowel contraction. If a subject marker ending in or only consisting of a vowel precedes either a tense morpheme with the same (initial) vowel or a verb stem that starts with the same vowel, the vowel of the subject marker contracts with the following vowel, as shown with the use of brackets in (173). However, since the focus of this chapter lies on the Bembe morphology, I will not signal vowel contractions.

- (173) a. *N(a)-a-ba-mon-a.*  
 1SG-N.PST-2OM-see-FV  
 “I have seen them.”
- b. *Anyoni (a)-a-chw-a.*  
 12bird 12SM-N.PST.come-FV  
 “The bird has come.”

*Expletive & infinitival markers*

Expletive (cl.15 *o-/ʔwa-* & cl.8 *bya-*) and infinitival markers (cl.5 *i-*) also find their place in the initial slot, as illustrated in (174) and (175), respectively.

- (174) a. *ʔwa-a-chw-a baana.*  
 15EXPL-N.PST-come-FV 2child  
 (Lit. “Have come the children.”)  
 “THE CHILDREN have come.”

- b. *ʔwa-a-chw-a*                      *beni?*  
 15EXPL-N.PST-come-FV 1who  
 (Lit. “Has come who?”)  
 “Who has come?”
- c. *By-a-hik-a*                      *baana ba-koch-ile bilewa.*  
 8SM-PRES-seem-FV 2child 2SM-buy-PST 8food  
 “It seems (that) the children bought food.”
- d. *Q-le*                      *bilewa bi-le mo-te-w-a.*  
 15EXPL-COP 8food 8SM-COP PROG-cook-PASS-FV  
 “There is food being cooked.”

- (175) a. *i-tend-a*  
 5SM-speak-FV  
 “to speak”
- b. *i-kol-a*  
 5SM-buy-FV  
 “to buy”

### 2.3.2.3 Post-initial position

#### *Negation marker (Neg2)*

A second negation marker *sha-* (and its allophone *shi-*) occupies the post-initial position, and surfaces in negated relative sentences (176), negated clefts (177), and with negated infinitives (178). The negative marker always follows relative, focus and infinitival markers, as illustrated in (178), respectively.

- (176) a. *mtu wa-sha-yak-ilé ngyoʔa*  
 1person 1REL-NEG-kill-PST 9snake  
 “the person who did not kill a snake”
- b. *mtu o-shi-ikyo-chimb-á.*  
 1man 1REL-NEG-HAB-lie-FV  
 “the man who does not (habitually) lie.”



- (177) a. *ʔe-le ʔetabo i-e-ba-sha-a-som-á.*  
 7SM-COP 7book FOC-7REL-2SM-NEG-N.PST-read-FV  
 “It is a book that they have not read (not a newspaper).”
- b. *Lo-b-ile lolo loho i-lwa-sha-koch-il-w-é.*  
 11SM-COP-PST 11DEM.med 11skin FOC-11REL-NEG-buy-PST-PASS-FV  
 “It was that skin that was not bought.”
- (178) a. *i-shi-tend-a*  
 5SM-NEG-speak-FV  
 “to not speak”
- b. *i-sha-kol-a*  
 5SM-NEG-buy-FV  
 “to not buy”

That the subordinate negation marker cannot possibly occupy the pre-initial position like the non-subordinate negation marker but is rather placed in post-initial position is explicitly demonstrated by Type 1 relative clauses such as in (179), which show unequivocally that *sha-* follows the subject marker in its initial position.

- (179) *bilewa bi-ba-sha-koch-ilé*  
 8food 8REL-2SM-NEG-buy-PST  
 “the food that they did not buy”

#### 2.3.2.4 TAM position

The T(ense)-A(spect)-M(ood) position is the locus of the TAM morphemes (cf. Nurse 2008: 14). Table 22 gives a schematic overview of the latter and their combinations with other verbal markers in Bembe, while the system of tense and aspect will be discussed more in detail in section 2.3.3.

Label	Formula
<u>PRESENT</u>	
General present	SM- <i>a</i> -(OM)-VB- <i>a</i>
Progressive present	a. SM- <i>mo</i> -VB-(OM)- <i>a</i>
	b. SM-COP <i>mo</i> -(OM)-VB- <i>a</i>

Habitual present	SM- <i>ikyo</i> -(OM)-VB- <i>a</i>
Persistive present	SM- <i>e</i> -COP <i>mo</i> -(OM)-VB- <i>a</i>
Prospective present	SM- <i>oso</i> -(OM)-VB- <i>a</i>
Optative present	EXPL- <i>na-shi-ile</i> INF-VB- <i>a</i>
Potential present	SM- <i>na</i> -VB- <i>a</i>
<u>PAST</u>	
General past	a. SM- Ø -(OM)-VB- <i>ile</i> b. SM- <i>lo</i> -(OM)-VB- <i>a</i>
Near past	SM- <i>a</i> -(OM)-VB- <i>a</i>
Far past	SM-COP- <i>ile</i> SM- <i>na</i> -VB- <i>a</i>
Perfective past	SM-COP- <i>ile</i> SM-VB- <i>a</i>
Progressive past	SM-COP- <i>ile</i> <i>mo</i> -VB- <i>a</i>
Habitual past	SM-COP- <i>ile</i> <i>mo</i> -VB- <i>a</i>
Persistive past	SM-COP- <i>ile</i> SM- <i>e</i> -COP <i>mo</i> -VB- <i>a</i>
Prospective past	SM-COP- <i>ile</i> SM- <i>oso</i> INF-VB- <i>a</i>
Optative past	SM- <i>na-shi</i> -VB- <i>ile</i>
Potential past	SM- <i>na</i> -VB- <i>ile</i>
<u>FUTURE</u>	
Near future (I)	SM- <i>ò/ó</i> -VB- <i>a</i>
Successive future	SM- <i>shi</i> -VB- <i>e</i>
Far future (II)	<i>i</i> -SM-VB- <i>a</i>
Perfective future	<i>i</i> -SM-COP- <i>a</i> SM-VB- <i>a</i> INF-VB- <i>a</i>
<u>OTHER</u>	
Imperative	Ø-VB- <i>a</i>
Hortative I	SM-VB- <i>e</i>
Hortative II	SM- <i>tang-a</i> INF-VB- <i>a</i>

Table 22: TAM MARKERS AND CONJUGATIONS<sup>11</sup>

<sup>11</sup> The position of object markers is indicated by '(OM)' and given only for those conjugations in which they are attested in the data set.

### 2.3.2.5 Pre-radical position

#### Object markers

Bembe cross-references object arguments in the form of object markers on the verb (cf. Riedel 2009; Marten & Kula 2012 among others). They agree in noun class with the arguments they replace and are available for nominals of all noun classes, except for locative nouns in Bembe.

- (180) a. *Baana ba-koch-ile bilewa.*  
2child 2SM-buy-PST 8food  
“The children bought food.”
- b. *Baana ba-bi-koch-ile.*  
2child 2SM-8OM-buy-PST  
“The children bought it.” (*bilewa* ‘the food’)
- c. *John a-a-lengany-a nibo Mary a-hib-ile eswe.*  
1John 1SM-PRES-think-FV that 1Mary 1SM- steal-PST 10fish  
“John thinks that Mary stole fish.”
- d. *John a-a-lengany-a nibo Mary a-chi-hib-ile.*  
1John 1SM-PRES-think-FV that 1Mary 1SM-10OM- steal-PST  
“John thinks that Mary stole it.” (*eswe* ‘fish’)

Both direct and indirect objects of a ditransitive verb can be replaced with a co-referential object marker, as illustrated in (181b-c). However, the examples in (181d) shows that the maximal number of object markers one the verb is limited to one in Bembe.

- (181) a. *Twa-h-ile batu bokyo.*  
1PL-give-PST 2person 14money  
“We gave people (some) money.”
- b. *Twa-bo-h-ile batu.*  
1PL-14OM-give-PST 2person  
“We gave it to people.” (*bokyo* ‘the money’)

- c. *Twa-ba-h-ile*      *bokyo*.  
 1PL-2OM-give-PST 14 money  
 “We gave them money.” (*batu* ‘the people’)
- d. \**Twa-ba-bo-h-ile*.      /      \**Twa-bo-ba-h-ile*  
 1PL-2OM-14OM-give-PST      1PL-14OM-2OM-give-PST  
 (Int. “We gave them it.”) (*batu* ‘the people; *bokyo* ‘the money’)

As is visible in (181c), arguments of the classes 1 and 2, the referents of which are exclusively human, can also be object-marked. For these classes, a distinction in person is made. The examples in (182) illustrate the paradigm of class 1 and 2 object markers.

- (182) a. *Bya-a-nd-choakech-a*.  
 8SM-PRES-OM.1SG-please-FV  
 “It pleases me.”
- b. *Bya-a-o-soakech-a*  
 8SM-PRES-OM.2SG-please-FV  
 “It pleases you.” (sg.)
- c. *Bya-a-m-soakech-a*  
 8SM-PRES-1OM-please-FV  
 “It pleases him/her.”
- d. *Bya-a-to-soakech-a*  
 8SM-PRES-OM.1PL-please-FV  
 “It pleases us.”
- e. *Bya-a-mu-soakech-a*  
 8SM-PRES-OM.2PL-please-FV  
 “It pleases you.” (pl.)
- f. *Bya-a-ba-soakech-a*  
 8SM-PRES-2OM-please-FV  
 “It pleases them.”

Object markers show co-occurrence restrictions with lexical objects, as they cannot appear freely with them or co-referential (emphatic) personal pronouns, as the examples in (183b-c) illustrate.

- (183) a. *John a-a-lengany-a nibo Mary a-tend-ile nibo Bill*  
 1John 1SM-PRES-think-FV that 1Mary 1SM-say-PST that 1Bill  
*a-hib-ile eswe.*  
 1SM-steal-PST 1ofish  
 “John thinks that Mary said that Bill stole fish.”
- b. \**John a-a-lengany-a nibo Mary a-tend-ile nibo Bill*  
 1John 1SM-PRES-think-FV that 1Mary 1SM-say-PST that 1Bill  
*a-chi-hib-ile eswe.*  
 1SM-10OM-steal-PST 1ofish  
 (Lit. “John thinks that Mary said that Bill stole it fish.”)  
 (Int. “John thinks that Mary said that Bill stole it/fish.”)
- c. \**John a-a-lengany-a nibo Mary a-tend-ile nibo Bill*  
 1John 1SM-PRES-think-FV that 1Mary 1SM-say-PST that 1Bill  
*a-chi-hib-ile echo.*  
 1SM-10OM- steal-PST 10PRO  
 (Lit. “John thinks that Mary said that Bill stole it it.”)  
 (Int. “John thinks that Mary said that Bill stole it.”)
- d. *John a-a-lengany-a nibo Mary a-tend-ile nibo Bill*  
 1John 1SM-PRES-think-FV that 1Mary 1SM-say-PST that 1Bill  
*a-chi-hib-ile.*  
 1SM-10OM-steal-PST  
 “John thinks that Mary said that Bill stole it.” (*eswe* ‘fish’)

The only possibility of having an object marker and a cross-referential object DP simultaneously is by separating the two by a clearly audible obligatory intonation break, as indicated by the comma.

- (184) a. *Eswe*, *John a-a-lengany-a nibo Mary a-tend-ile nibo Bill*  
 1ofish 1John 1SM-PRES-think-FV that 1Mary 1SM-say-PST that 1Bill  
*a-chi-hib-ile.*  
 1SM-10OM- steal-PST  
 “The fish, John thinks that Mary said that Bill stole it.”

- b. *John a-a-lengany-a nibo Mary a-tend-ile nibo Bill*  
 1John 1SM-PRES-think-FV that 1Mary 1SM-say-PST that 1Bill  
*a-chi-hib-ile* \*(,) *eswe.*  
 1SM-10OM- steal-PST 10fish  
 “The fish, John thinks that Mary said that Bill stole it.”

Table 23 shows the paradigm of object markers in Bembe.

Class	Person	Object marker
	1SG	<i>nd-/ng-</i>
	2SG	<i>o-/wa-</i>
1	3SG	<i>m-</i>
	1PL	<i>to-</i>
	2PL	<i>mo-</i>
2	3PL	<i>ba-</i>
3		<i>ho-</i>
4		<i>he-</i>
5		<i>le-</i>
6		<i>ma-</i>
7		<i>(h)e-</i>
8		<i>bi-</i>
9		<i>ya-</i>
10		<i>chi-</i>
11		<i>lo-</i>
12		<i>a-</i>
13		<i>to-</i>
14		<i>bo-</i>
15		<i>ʔo-</i>
16		---
17		---
18		---
19		<i>hi-</i>

Table 23: BEMBE OBJECT MARKERS

A detailed discussion of Bembe object marking is presented in Chapter 3.

*Reflexive markers*

Besides the use of lexical reflexives (section 2.2.3), another strategy for reflexivisation in Bembe consists of cliticising the reflexive marker *hi-* to the verb. The reflexive marker must appear immediately to the left of the verb root, i.e. in the pre-radical position that is usually occupied by the object marker. Reflexive markers refer to the agent/experiencer of the verb and appear in the same morphological slot as object markers, i.e. immediately preceding the verbal root.

(185) a. *Ta-ba-na-hi-yak-a.*

NEG-2SM-POT-REF-kill-FV

“They cannot kill themselves.”

b. *Ta-ba-na-ile o-hi-yak-a.*

NEG-2SM-POT-PST 15SM-REF-kill-FV

“They could not kill themselves.”

c. *Omo wetu a-hi-yak-ile.*

1one us 1SM-REF-kill-PST

“One of us has killed himself.”

d. *Mtu wa-hi-yak-ile a-a-chw-a longe.*

1man 1REL-REFL-hurt-PST 1SM-N.PST-come-FV again

“The man who hurt himself has come again.”

A lexical reflexive can also be added to a sentence that already displays a reflexive marker on the verb. Given the similarity to object markers, the co-occurrence restrictions that hold between object markers and lexical objects expectedly also hold between reflexive markers and lexical reflexives: the latter have to be separated from the rest of the clause by an intonation break if they appear simultaneously with a reflexive marker, as indicated by the comma in the examples in (186). The emphasis reading of the agent/experiencer of the action denoted by the verb persists in these cases.

- (186) a. *Omo wetu a-hi-yak-ile* \*(,) *ewe imwene*.  
 1one us 1SM-REF-kill-PST he self  
 (Lit. “One of us has killed himself, himself.”)  
 “One of us has killed himself(!).”
- b. *Mtu wa-hi-yak-ile* \*(,) *ewe imwene, a-a-chw-a* *longe*.  
 1man 1REL-REFL-hurt-PST he self 1SM-N.PST-come-FV again  
 (Lit. “The man who hurt himself, himself, has come again.”)  
 “The man who hurt himself(!) has come again.”

The examples in (187) illustrate the reflexive paradigm for all grammatical persons of the classes 1 and 2.

- (187) a. *Na-a-(hi)-chic-a* (*ine imwene*).  
 1SG-N.PST-REF-hurt-FV I self  
 “I have hurt myself(!).”
- b. *Wa-a-(hi)-chic-a* (*obe imwene*).  
 2SG-N.PST-REF-hurt-FV you self  
 “You have hurt yourself.”
- c. *A-a-(hi)-chic-a* (*ewe imwene*).  
 1SM-N.PST-REF-hurt-FV he self  
 “S/he has hurt her/himself.”
- d. *Twa-a-(hi)-chic-a* (*bechu imwene*).  
 1PL-N.PST-REF-hurt-FV we self  
 “We have hurt ourselves.”
- e. *Mwa-a-(hi)-chic-a* (*benu imwene*).  
 2PL-N.PST-REF-hurt-FV you self  
 “You have hurt yourselves.”
- f. *Ba-a-(hi)-chic-a* (*ebɔ imwene*).  
 2SM-N.PST-REF-hurt-FV they self  
 “They have hurt themselves.”

A summary of the verbal agreeing prefixes in the pre-initial, initial and pre-radical positions, respectively, are shown in Table 24.



Class	Person	Relative marker	Subject marker	Object marker
	1SG	<i>o-/wa-</i>	<i>na-/ni-</i>	<i>nd-/ng-</i>
	2SG	<i>o-/wa-</i>	<i>o-/wa-</i>	<i>o-/wa-</i>
1	3SG	<i>o-/wa-</i>	<i>a-</i>	<i>m-</i>
	1PL	<i>to-/twa-</i>	<i>to-/tw-</i>	<i>to-</i>
	2PL	<i>mu-/mwa-</i>	<i>mu-/mwa-</i>	<i>mo-</i>
2	3PL	<i>ba-</i>	<i>ba-</i>	<i>ba-</i>
3		<i>o-/wa-</i>	<i>o-/wa-</i>	<i>ho-</i>
4		<i>he-</i>	<i>ya-</i>	<i>he-</i>
5		<i>le-</i>	<i>lya-</i>	<i>le-</i>
6		<i>ma-</i>	<i>ma-</i>	<i>ma-</i>
7		<i>(?)e-</i>	<i>ea-/ya-</i>	<i>(h)e-</i>
8		<i>bi-</i>	<i>bya-</i>	<i>bi-</i>
9		<i>y-</i>	<i>ya-</i>	<i>ya-</i>
10		<i>cha-/chi-</i>	<i>cha-</i>	<i>chi-</i>
11		<i>lo-</i>	<i>lwa-</i>	<i>lo-</i>
12		<i>ʔa-</i>	<i>a-</i>	<i>a-</i>
13		<i>to-</i>	<i>twa-</i>	<i>to-</i>
14		<i>bo-</i>	<i>bwa-</i>	<i>bo-</i>
15		<i>ʔo-/ʔw-</i>	<i>ʔo-/ʔwa-</i>	<i>ʔo-</i>
16		<i>ha-</i>	<i>a-</i>	–
17		<i>o-/ʔw-</i>	<i>ʔo-/ʔwa-</i>	–
18		<i>m-/mw-</i>	<i>mu-/mwa-</i>	–
19		<i>hi-/i-</i>	<i>hi-</i>	<i>hi-</i>

Table 24: AGREEING PREFIXES IN THE VERBAL DOMAIN

### 2.3.2.6 Radical position

#### *Verb root*

The canonical syllabic form of the verbal root in Bembe is CVC, although there exist verbal roots which consist of only one or two phonemes. The number of verb roots in the database which are made up of more than three phonemes is limited, and such forms may be the result of extensions which have been lexicalised, such as in *i-soakech-a* ‘to

please sb.’ (CVVCVC) where the *-ch-* may originally have been a causative extension. The syllabic forms of verb roots are listed in Table 25.

Syllable structure	Example	Gloss
C	<i>b</i>	‘to be, have’
S	<i>y</i>	‘to go’
	<i>w</i>	‘to finish’
V	<i>ε</i>	‘to slice’
	<i>o</i>	‘to slide’ (landslide)
	<i>u</i>	‘to revive’
VC	<i>ó<sup>n</sup>d</i>	‘to be soft’
VN	<i>am</i>	‘to dry’
CV	<i>se</i>	‘to laugh’
	<i>be</i>	‘to be ugly’
CS	<i>ly</i>	‘to eat’
	<i>ʔw</i>	‘to die’
CVC	<i>kol</i>	‘to buy’
	<i>yak</i>	‘to kill’
	<i><sup>n</sup>gal</i>	‘to shine’
	<i>bis</i>	‘to hide’
	<i>cha<sup>n</sup>g</i>	‘to follow’
VCV	<i>olo</i>	‘to fall’
CVCS	<i>lok<sup>w</sup></i>	‘to be sad’
CSVC	<i>ʔwat</i>	‘to dress’
	<i>kwel</i>	‘to fall’
CSVN	<i>hwan</i>	‘to fight’
CVCVN	<i>hikan</i>	‘to stand up’
CVNVN	<i>chimin</i>	‘to get lost’
CVVCVC	<i>soakech</i>	‘to please’
CVCVNS	<i>le<sup>n</sup>gany</i>	‘to think’

Table 25: SYLLABIC FORM OF BEMBE VERB ROOTS

### 2.3.2.7 Post-radical position

The post-radical position is the domain of the so-called verb extensions, which fulfil a number of different functions (cf. Nurse 2008: 259). They either increase or decrease

the valence of the verb, (re-)orient the action of the verb, or are used to mark aspect. Thus, most extensions fulfil derivational functions, although some may encode inflectional categories (Hyman 2007). Several extensions may co-occur on a verb, and if they do so, they typically follow a canonical order: causative > applicative > reciprocal > passive (Hyman 2002), although there exists variation. In what follows, I will describe the extensions found in Bembe. Note that I do not claim this list to be exhaustive.

*Passive (-w)*

The passive in Bembe is marked with the verbal extension *-w*, which always occupies the pre-final position on the verb, as illustrated in (188).

- (188) *i-kol-w-a* ‘to be bought’ (< *i-kola* ‘to buy’)  
*i-yak-w-a* ‘to be killed’ (< *i-yaka* ‘to kill’)  
*i-tend-w-a* ‘to be said, spoken’ (< *i-tenda* ‘to say, speak’)

However, note that the combination of the passive morpheme *-w-* with the final past-tense morpheme *-ile*, does not result in the sequence *-w-ile-*. Instead, the two suffixes seem to fuse together resulting in the sequence *il-w-e* – a process known as *imbrication*. This is illustrated in the examples in (189).

- (189) a. *Numba ya-koba-il-w-e.*  
9house 9SM-build-PASS-PST  
‘The house was built.’
- b. *Baetu bahikechwa ba-sang-il-w-e.*  
2POSS.1PL 2student 2SM-meet-PST-PASS-PST  
‘Our students were met.’

In a passive construction, the passivised object is promoted to grammatical subject and preposed into the preverbal position while the logical subject is demoted and expressed in a Bantu-typical optional “by”-clause, introduced by the preposition *na*. Subject marking agrees in noun class with the preposed object and not the logical subject.

- (190) a. *Numba ya-koba-il-w-e* ( *na Iddi*).  
 9house 9SM-build-PST-PASS-PST by 1Iddi  
 “The house was built by Iddi.”
- b. *Ba-senyinyu-w-e* ( *na nguku*).  
 2SM-chase-PASS-PST by 10hippopotamus  
 “They were chased by hippopotami.”

Bembe shows what is referred to as symmetrical passive, i.e. indirect (191b) as well as direct objects (191c) in passive ditransitives can be promoted to grammatical subject and force its corresponding subject marker onto the verb.

- (191) a. *Twa-h-ile baana bitabo*.  
 1PL-give-PST 2child 8book  
 “We gave the children (some) books.”
- b. *Baana ba-h-il-w-e bitabo ( na wetu)*.  
 2child 2SM-give-PST-PASS-PST 8book by us  
 “The children were given (some) books (by us).”
- c. *Bitabo bya-h-il-w-e baana ( na wetu)*.  
 8books 8SM-give-PST-PASS-PST 2child by us  
 “The books were given to the children (by us).”

Both direct and indirect object can be also be passivised in applicative constructions, as (192) illustrates.

- (192) a. *Baana ba-a-h-el-a lobonga mtu bilewa*.  
 2child 2SM-N.PST-give-APPL-FV 11church 1person 8food  
 “The children have given the man food on behalf of the church.”
- b. *Bilewa bya-h-el-w-a lobonga mtu na baana*.  
 8food 8SM-give-APPL-PASS-FV 11church 1person by 2child  
 “The food has been given to the man on behalf of the church by the children.”
- c. *mtu a-h-el-w-a lobonga bilewa na baana*.  
 1man 1SM-give-APPL-PASS-FV 11church 8food by 2child  
 “The man has been given food by the children on behalf of the church.”

Passive verbs can also be formed from an intransitive verb, resulting in a so-called impersonal passive, in which the agent of the action is demoted. The demoted subject can optionally appear in a by-phrase. However, subject marking on the verb is with the class 15 marker *o-/ɔwa-*, which acts as expletive subject.

- (193) *ɔwa-sen-in-w-e* (na baana).  
 15EXPL-run-PST-PASS-PST by 2child  
 “There was running (by the children).”

Interestingly, impersonal passives are also possible with transitive verbs. However, in contrast to impersonal passives with intransitive verbs, the logical subject cannot be expressed in a by-phrase. This is shown in (194).

- (194) a. *ɔwa-a-kol-w-a* mleka manga ( \*na baana).  
 15EXPL-N.PST-buy-PASS-FV 3beans many by 2children  
 “There were many beans being bought.”
- b. *O-le* bilewa bi-le mo-te-w-a ( \*na Iddi)  
 15EXPL-COP 8food 8SM-COP PROG-make-PASS-FV by 1Iddi  
 “There is food being made.”

#### *Stative (-am)*

The extension *-am* indicates the existing state resulting from an action as denoted by the verb. It is similar to the passive extension in that it is of an intransitivising nature but differs in that it does not permit the agent of the action to be expressed (as opposed to the passive where it is expressed in a by-phrase).

- (195) a. *i-bis-am-a* ‘to be hidden’ (< *i-bis-a* ‘to hide’)  
*i-kyek-am-a* ‘to be laid down’ (< *i-kyek-a* ‘to lie down’)
- b. *Na-a-y-a* o-kyek-am-a.  
 1SG-PRES-go-FV 15SM-lay.down-STAT-FV  
 (Lit. “I go to be laid down.”)  
 “I am going to lie down.”

*Reciprocal (-an)*

The reciprocal extension *-an* indicates the reciprocity of the action denoted by the verb. In order to form a reciprocal form of a verb, the verb must at least be transitive.

- (196) a. *i-lol-an-a* ‘to visit/look at each other’ (< *i-lol-a* ‘look/visit’)  
*i-boch-an-a* ‘to call each other’ (< *i-boch-a* ‘to call’)  
*i-bel-an-a* ‘to leave each other’ (< *i-bel-a* ‘to break’)  
*i-somb-an-a* ‘to hate each other’ (< *i-somb-a* ‘to hate’)
- b. *Steve na Jim ba-a-somb-an-a.*  
1Steve and 1Jim 2SM-PRES-hate-REC-FV  
“Steve and Jim hate each other.”

*Applicative (-il/-in, allomorphs -el/-en)*

The applicative form of the verb is composed of the extensions *-il/-in* in Bembe (or *-el/-en-* in case of vowel and vowel & nasal harmony, respectively). The applicative extension is often polysemous in Bantu, with the most-frequently encountered functions being benefactive, malefactive, instrumental, locative, recipient, allative, circumstance or manner. However, Bembe does not display all of these functions. The applicative extension introduces an additional argument to the verb. Since applicativised verbs always sub-categorise for an additional argument, the applicative extensions is said to increase the valence of a verb. In a sense, the applicatives thus take up the function fulfilled in other languages by prepositions, which Bembe in fact uses in a rather limited way (see section 2.2.11).

The applicative extension in Bembe frequently indicates that the action denoted by the verb is performed on behalf of or for sb./s.th, as illustrated with the benefactive use of an applicative verb form in (197). The word order is always such that the newly introduced, applied object precedes any other object of the verb.

- (197) a. *Iddi a-lo-kol-el-a* *Rose bitabo.* (Benefactive)  
1Iddi 1SM-PST-buy-APPL-FV 1Rose 8book  
“Iddi bought books on behalf of/for Rose.”

- b. *Baana ba-a-bis-el-a*                      *Maria bitabo.*  
 2child 2SM-N.PST-hide-APP-FV    1Mary 8book  
 “The children have hidden the books on behalf of/for Mary”

The applicative extension can also be used to add a malefactive participant, meaning that the action denoted by the verb is performed to the detriment of an additional participant. According to my language informants, context is mainly responsible for determining whether an applicative is used in its benefactive or malefactive sense, although they contend that benefactive applicatives are far more frequent than malefactive ones. Note that benefactive/malefactive objects can also be expressed via object markers on the verb, as in (198).

- (198) *Na-a-o-sol-el-a*                      *ekombe ya mata.*                      (Malefactive)  
 1SG-N.PST-OM2SG-drink-APPL-FV 7glass 7of 3milk  
 “I have drunk a glass of milk on behalf of you.” or  
 “I have drunk a glass of milk on you.” (meaning: ‘your glass’)

However, not all verbs allow a malefactive reading of the applied object. Consider the case of the verb *ihiba* ‘to steal’ in (199), in which the malefactive meaning is expressed by default without the insertion of an applicative extension.

- (199) a. *Na-a-o-hib-el-a*                      *bilewa.*  
 1SG-N.PST-OM2SG-steal-APPL-FV 8food  
 “I have stolen food for/on behalf of you.”
- b. *#Na-a-o-hib-el-a*                      *bilewa.*  
 1SG-N.PST-OM2SG-steal-APPL-FV 8food  
 (Int. “I have stolen food from you.”)
- c. *Na-a-(o)-hib-a*                      *bilewa.*  
 1SG-N.PST-OM2SG-steal-FV 8food  
 “I have stolen food (from you).”

Besides the context, it seems reasonable to assume that the very semantics of the verb is responsible for prohibiting a malefactive reading of the applied verb-form of *ihiba* ‘to steal’, since the applied object of the non-applied verb in (199c) will in any case be

interpreted as being the maleficent of the action as denoted by the verb *ihiba* ‘to steal’, something that, in contrast, is not necessarily given in the case of the verb *isola* ‘to drink’, as in (198). Thus, if an applicative is added to the verb *ihiba* ‘to steal’, as in (199a), it is actually to signal that the action of stealing has been carried out to the benefit of somebody.

Some Bantu languages allow the use of applicative extensions in order to form so-called instrumental applicatives. These indicate that the action denoted by the verb is performed with the help of something. However, in the Bembe examples in (200a-b) the applicative extension does not add the meaning of indicating that the action denoted by the verb is performed with the help of something, in this case the stone (i.e. an instrumental applicative) but rather the non-sensical meaning that the door has been broken on behalf of the stone. The examples (200a-b) contrast an applied verb with a non-human benefactive object, which is intended to render an instrumental reading on the benefactive object, with the prepositional instrumental (200c), which is usually employed in Bembe to signal the use of something as an instrument.

- (200) a. \**Ba-lo-bel-el-a*            *hibwe*    *mchango*.                    (Appl. Instrumental)  
           2SM-PST-break-APPL-FV 5stone    3door  
           (Int. “She broke the door with a stone.”)  
           ??“S/he broke the door on behalf of a stone.”
- b. \**A-a-yak-el-el-a*            *baana*    *mwele*    *nyama*.  
           1SM-N.PST-buy-APPL-APPL-FV 2child    3knife    9animal  
           (Int. “S/he has killed the animal for the children with a knife.”)
- c. *Ba-bech-ile*    *mchango*    *na*    *hibwe*.                    (Prepositional Instrumental)  
           2SM-break-PST 3door        with    5stone  
           “S/he broke the chains with a stone.”

An applied verb in Bembe can also signal that the action denoted by the verb is performed somewhere in particular, i.e. it can act as locational applicative, rather than signaling that an action is performed to the benefit or detriment of somebody. Notice that the use of nominals with locations as their reference makes applicative marking on the verb obligatory, as illustrated in (201). Otherwise, the meaning of the sentence would be non-sensical, akin to “The church which I have prayed was big.”



- (201) *Lobonga ló-ni-b-ile mo-hon-\*(en)-a lo-b-ile*  
 11church 11REL-1SG-COP-PST PROG-pray-APPL-FV 11SM-was-PST  
*lwa mmolo.*  
 11CONN bigness  
 (Lit. “The church where/which (I) was praying in was of bigness.”)  
 “The church where/which (I) was praying in was big.”

As opposed to other Bantu languages, e.g. Makhuwa, applicative verbs do not induce a goal/direction reading if used with verbs that already take a locative argument. This is shown in (202).

- (202) a. *Na-a-nyat-a m-ndalo.*  
 1SG-PRES-walk-FV 18LOC-9field  
 “I walk in the field.”  
 b. *\*Na-a-nyat-el-a o-ndalo.*  
 1SG-PRES-walk-APPL-FV 17LOC-9field  
 (Int. “I walk to the field”)

Interestingly, if a sentence contains more than one applied object with different semantic roles, for instance a benefactive and a locative one, more than one applicative morpheme has to appear on the verb. Without a second applicative extension, the example in (203) is otherwise non-sensical.<sup>12</sup> There is, however, not enough data in the data set to determine the upper limit of applicative extensions on one verb.

- (203) a. *lobonga ló-to-b-ile mo-hon-en-en-a baana*  
 11church 11REL-1PL-COP-PST PROG-pray-APPL-APPL-FV 2child  
 “the church in which we were praying for the children”  
 b. *\*lobonga ló-to-b-ile mo-hon-en-a baana*  
 11church 11REL-1PL-COP-PST PROG-pray-APPL-FV 2child  
 (Lit. “the church which we were praying for the children”)   
 (Int. “the church in which we were praying for the children”)

---

<sup>12</sup> While the example with one applicative extension is strictly speaking ungrammatical, my language informants contend that it is understood in the sense expressed by the first example.

When combined with a reversive extension, the applicative morpheme always follows it.

- (204) *A-lo-chi-ol-el-a*                      *batu*      *nyama*.  
 1SM-PST-bury-REV-APPL-FV 2person 10animal  
 “S/he exhumed the animals on behalf of the people.”

Note that it is not possible to use the applicative extension with a verb that simultaneously carries the past-tense marker *-ile* in final position. Instead, the alternative past-tense form with the past-tense marker *lo-* in TAM position has to be employed.

- (205) a. \**Ba-kol-el-ile*                      *Iddi*.  
 2SM-buy-APPL-PST 1IDDI.  
 (Int. “They bought it for Iddi.”)
- b. *Ba-lo-kol-el-a*                      *Iddi*.  
 2SM-PST-buy-APPL-FV 1IDDI.  
 “They bought it for Iddi.”

*Intensive (-elel)*

Another instance of what seems to be an applicative morpheme appearing twice on the verb, is in fact a lexicalized, reduplicated form of the applicative morpheme, namely the intensive extension *-elel* (and its allomorph *-elech*). The intensive extension in Bembe indicates that the action denoted by the verb is performed exhaustively. As the examples in (206) show, however, the extension can also be used to express a more nuanced meaning than the one originally expressed by the verb. While I assume that the intensive derives from the applicative extension – purely based on its shape, presumably by reduplication – it does not introduce additional arguments.

- (206) *i-el-a* ‘to drop’ > *i-el-elech-a* ‘to put into place’  
*i-bel-a* ‘to break’ > *i-be-elech-a* ‘to grind, to analyse’  
*i-toch-a* ‘to ask’ > *i-tot-elech-a* ‘to scrutinize, to ask vigorously’

- (207) a. *Baana ba-a-bis-elel-a bitabo.*  
 2child 2SM-N.PST-hide-INT-FV 8book  
 “The children have hidden the books completely.”
- b. *Mwa-a-sol-elel-a maonde.*  
 2PL-N.PST-drink-INT-FV 6alcoholic.drinks  
 “You have drunk all the drinks.”

*Causative (-i; allomorphs -ch, -shi)*

The causative extension in Bantu indicates that the action denoted by the verb has been caused by somebody/something else than the subject of the originally non-causative verb. Causative extensions thus take up the function of what other languages may express with the help of causative verbs, like *make* in English. In Bembe, causative verb forms are formed by attaching the causative extension *-i* (or its allomorphs *-chi* and *-shi*) to a position between verbal stem and final vowel. Like applicatives, causatives increase the valence of the verb by one, and the newly introduced argument receives the semantic role of agent-causer, i.e. the causer of the action denoted by the verb. The original agent of the non-causative verb is now expressed as the object of the causative verb, as illustrated in (208).

- (208) a. *Iddi a-a-ly-a mleka.*  
 1Iddi 1SM-N.PST-eat-FV 3beans  
 “Iddi has eaten beans.”
- b. *Rose a-a-le-sh-a Iddi mleka.*  
 1Rose 1SM-N.PST-eat-CAUS-FV 1Iddi 3beans  
 (Lit. “Rose has made Iddi eat beans.”)  
 “Rose has fed Iddi beans.”

A list of examples of causative forms of common verbs is given in (209). There exist lexicalized causative verbs, as exemplified in (209a), the semantic meaning of which can still be paraphrased as ‘to cause to do X’. However, although the non-causative meaning of the non-causative verb root is not always discernable, the causative extension is still highly productive, as the list of randomly chosen verbs in (209b) shows.

- (209) a. *i-samb-y-a* ‘to mix, reunite’ (lexicalised)  
*i-ch-i-a* ‘to bury’ (lexicalised)  
‘to be made extinct’
- b. *i-lok-y-a* ‘to make angry’ (< *i-lokw-a* ‘to be angry’)  
*i-o-y-a* ‘to lower’ (< *i-o-a* ‘go down’)\  
*i-kónd-ch-a* ‘make s.b. thin’ (< *i-kónd-a* ‘to thinen’)  
*i-soake-ch-a* ‘to please’ (< *i-soakel-a* ‘to be happy’)  
*i-lónd-ch-a* ‘to cause difficulty’ (< *i-lónd-a* ‘to be difficult’)  
*i-bo-ch-a* ‘cause to rot, ferment’ (< *i-bol-a* ‘to rot’)  
*i-ond-ch-a* ‘to cause to become soft’, (< *i-ónd-a* ‘to be soft’)  
‘to soften’  
*i-chund-ch-a* ‘to cause to become bigger’, (< *i-chund-a* ‘to be big’)  
‘to biggen’  
*i-fe-ch-a* ‘to cause to become short’, (< *i-fel-a* ‘to be short’)  
‘to shorten’

There exists also a periphrastic construction to express that an action as denoted by the verb has been caused to be undertaken by somebody in Bembe. For this purpose, a passivised form of the lexical verb *itoma* ‘to send’ is used in conjunction with a verb that describes the action that has been caused to be undertaken.

- (210) a. *Na-a-tom-w-a*                      *ni-hib-e*                      *bokyo.*  
1SG-N.PST-send-PASS-FV    1SG-steal-FV    14money  
(Lit. “I have been sent I steal money.”)  
“I have been made to steal the money.”
- b. *Na-a-tom-w-a*                      *i-hib-a*                      *bokyo.*  
1SG-N.PST-send-PASS-FV    5SM-steal-FV    14money  
(Lit. “I have been sent to steal money.”)  
“I have been made to steal the money.”

In (210a) the second verb is inflected for person and appears in its subjunctive form, while in (210b) it surfaces in its infinitival form. Note that the final vowel in the first form is *-e*, while it is *-a* in the second. Interestingly, Bembe speakers rate the appropriateness of the two forms according to the context. Imagine a context in which

(210) is uttered by a person which has been apprehended in an area close to where a theft has taken place. If that person uses the form in (210a), he would unmistakably make clear that s/he has committed the act of stealing (irrespective of the question whether the act has been completed or not). If, however, he uses (210b), s/he expresses that the act of stealing has merely been planned but has not (yet) been undertaken.

The combination of a causative and a passive extension in Bembe changes the agentivity of a verb, as the both extensions are responsible for introducing an agentive subject (*Mary*) and demoting the original subject (*they*) to patient, as shown in the contrast between (211a-b).

- (211) a. *Ba-a-ly-a*                      *mleka*.  
           2SM-N.PST-eat-FV    3beans  
           ‘‘They have eaten beans.’’
- b. *Ba-a-le-shi-w-a*                      *mleka*    (*na Mary*).  
           2SM-N.PST-eat-CAUS-PASS-FV    3beans    (by 1Mary)  
           (Lit. ‘‘They have been caused to eat beans (by Mary)’’)  
           ‘‘They have been fed beans by Mary.’’

When combined with an applicative morpheme, the order is always such that the causative morpheme precedes the applicative, as shown in (212).

- (212) *Wa-a-koch-i-el-a*                      *John Mary make?*  
           2SG-N.PST-buy-CAUS-APPL-FV    1John 1Mary 6egg  
           (Lit. ‘‘You have caused to buy John Mary eggs?’’)  
           ‘‘You have caused John to buy eggs on behalf of/for Mary?’’

However, notice that not every instance of combining a causative and an applicative extension is deemed grammatical, as illustrated in (213). It is not clear (to me at least) at this point, what determines the grammaticality or ungrammaticality of their combination.

- (213) \**Ba-a-te-i-el-a*                      *John Mary*.  
           2SM-N.PST-speak-CAUS-APPL-FV    1John 1Mary  
           (Int. ‘‘They have made John to speak on behalf of Mary.’’)

*Reversive (-ɔl)*

The reversive verb form is formed by attaching the marker *-ɔl-* to a verb and indicates the reverse state or result of the action denoted by the verb, as shown in (214).

- (214) a. *Ba-lo-ba-kang-a*.  
2SM-PST-2OM-arrest-FV  
“They arrested them.”
- b. *Ba-lo-ba-kang-ɔl-a*.  
2SM-PST-2OM-arrest-REV-FV  
“They released them.”

When combined with an applicative morpheme, the order is always such that the reversive morpheme precedes the applicative, as shown in (215).

- (215) *A-lo-chi-ɔl-el-a*                      *batu*    *nyama*.  
1SM-PST-bury-REV-APPL-FV    2person    10animal  
“S/he exhumed the animals on behalf of the people.”

- (216) *i-kang-ɔl-a* ‘to detach, release’                      (< *i-kang-a* ‘to attach, arrest’)  
*i-samb-ɔl-a* ‘to disunite’                                      (< *i-samb-y-a* ‘to reunite’)  
*i-teʔk-ɔl-a* ‘to release from a trap’                      (< *i-teʔk-a* ‘to trap’)  
*i-chi-ɔl-a* ‘to exhume’    (< *i-chi-a* ‘to bury’)  
*i-kal-ɔl-a* ‘mix’    (< *i-kal-a* ‘transform, change’)

*Durative (-ak)*

“The durative extension in Bantu usually expresses that an action is extended in time or space, or repeated extensively” (Lodhi 2002). However, the Bembe durative morpheme *-ak-* only appears in conjunction with a negative marker in my data set. In negated structures it conveys that an action as expressed by the verb never has been undertaken or never will be. It attaches to a position preceding the final vowel. This is illustrated in (217).

- (217) a. *Shi-na-a-tend-ak-a*                      *bibio*    *longe*.  
NEG-1SG-N.PST-say-DUR-FV    8DEM.DIST    again  
“I have never said that again.”

- b. *Shi-shi-tend-ak-e*            *bibio*        *longe*.  
 NEG-1SG.FUT-say-DUR-FV    8DEM.DIST    again  
 “I will never say that again.”
- c. *Shi-na-a-mon-ak-a*            *mtu*        *o-shi-ikyo-chimb-á*.  
 NEG-1SG-N.PST-see-DUR-FV    1man    1REL-NEG-HAB-lie-FV  
 “I have never seen any man/anybody who does not lie.”

*Order of verbal extensions*

The following combinations of extensions are attested in the data set:

(STAT-APPL)	<i>i-bís-am-in-a</i>	‘to be hidden [state] on behalf of sb.’
(INT-PASS)	<i>i-bís-elel-w-a</i>	‘to be hidden [action] completely’
(CAUS-PASS)	<i>i-le-shi-w-a</i>	‘to be fed’ (Lit. ‘caused to eat’)
(APPL-PASS)	<i>i-bís-el-w-a</i>	‘to be hidden [action] on behalf of sb.’
(APPL-PASS)	<i>i-yak-el-w-a</i>	‘to be killed on behalf of sb.’
(CAUS-APPL)	<i>i-a-koch-i-el-a</i>	‘to make sb. buy s.th. on behalf of sb.’
(REV-APPL)	<i>i-kang-ɔl-el-a</i>	‘to release s.th. on behalf of sb.’
(REV-APPL-RCP)	<i>i-kang-ɔl-el-an-a</i>	‘to release s.th. on behalf of each other’
(STAT-RCP)	<i>*i-bís-am-an-a</i>	(Int. ‘to be hidden [state] from each other’)
(APPL-RCP)	<i>*i-bís-el-an-a</i>	(Int. ‘to hide s.th. from each other on behalf of sb.’)
(CAUS-APPL-PASS)	<i>*i-yak-ia-el-w-a</i>	(Int. ‘to cause to be killed for sb.’)
(REV-APPL-RCP-CAUS)	<i>*i-kang-ɔl-el-an-i-a</i>	(Int. ‘to make sb. release s.th. on behalf of each other’)

On the bases of the above (non-exhaustive) data, we can deduce that the order of the extensions must be as illustrated in (218).

- (218)    Stative > reversive > causative > applicative > reciprocal/passive

### *Reduplication*

The reduplication of the verbal root indicates a prolonged, locally extended, repetitive or intensified interpretation of the action denoted by the verb.

- (219) *i-changa-chang-a* ‘to follow sb. everywhere’ (< *i-changa* ‘to follow’)  
*i-lala-lal-a* ‘to be lazy’ (< *i-lala* ‘to sleep’)  
*i-nyata-nyat-a* ‘to be outgoing’ (pejorative) (< *i-nyata* ‘to walk’)  
*i-sea-se-a* ‘to laugh constantly’ (< *i-sea* ‘to laugh’)  
*i-ténda-tend-a* ‘to speak excessively’ (< *i-ténda* ‘to speak’)

- (220) a. *Na-a-changachang-a* Mary.  
1SG-PRES-follow.RED-FV 1Mary  
(Lit. “I follow follow Mary.”)  
“I follow Mary everywhere.”
- b. *Bobe baana ba-ikyo-lalalal-a.*  
2SG.POSS 2child 2SM-HAB-sleep.RED-FV  
(Lit. “Your children sleep sleep.”)  
“Your children are lazy.”

#### *2.3.2.8 Final position*

The final verb slot is occupied by a small set of mutually exclusive morphemes, also known as final vowels in other Bantu languages (with the exception of *-ile* which is generally referred to as anterior/past morpheme (Nurse 2008: 38)). In Bembe these are *-a*, *-e*, and *-ile*, which are used to signal the grammatical categories mood and tense. The final vowel *-a* is used for the indicative or imperative mood (221a-b), *-e* expresses the subjunctive mood, for instance in the hortative (221c), and the morpheme *-ile* is used for general-past tense of the indicative mood, as illustrated in (221d). Note that the final vowel *-e* is also used in the formation of the successive-future tense, as shown in (221e), and in negated imperative verb forms (prohibitives) (221f).

- (221) a. *A-a-hingel-a.*  
1SM-N.PST-enter-FV  
“He has entered.”



- b. *Kol-a kyenge!*  
 buy-FV 9fufu  
 “Buy (some) fufu!”
- c. *Mo-y-e o-mboka*  
 1PL-go-FV 17LOC-3village  
 “Let us go to the village.”
- d. *Na-koch-ile kyenge.*  
 1SG-buy-PST 9fufu  
 “I bought (some) fufu.”
- e. *Mwa-shi-tend-e.*  
 2PL-S.FUT-speak-FV  
 “(and then) you (pl.) will speak.”
- f. *Ta-mu-tend-e.*  
 NEG-2PL-speak-FV  
 “Do not speak.” (pl.)

### 2.3.3 The tense/aspect/mood (TAM) system

This section presents the different TAM markers in Bembe and their use. Tense sets up a time framework for the listener, aspect establishes how the situation is distributed within that time framework, and (grammatical) mood expresses the speaker’s attitude towards the content of the proposition (desire, factual statement, command etc.). Bembe expresses tense and aspect in the TAM and final position, and TAM position, respectively. Both can also be expressed by the use of compound constructions. Grammatical Mood, in contrast, is expressed in either the post-post-initial or final position (e.g. indicative, subjunctive etc.). I choose to describe the tense, aspect and mood systems jointly, and the remainder of this subsection contains the conjugations attested in Bembe, which are divided into affirmative and negative conjugations.

#### 2.3.3.1 Affirmative conjugations

##### *General present*

The general present tense is used to refer to the vast present, i.e. generic or frequent situations, and is expressed by the tense marker *a-* in TAM position and the final vowel

-a. It cannot be used for near future reference but may be used, instead of the progressive tense, to express that an action is ongoing.

- (222) a. *Mwa- a- lond- a Iddi.*  
 2PL- PRES- search- FV 1Iddi  
 “You search for Iddi.”
- b. *Ba- a- tend- a Bembe.*  
 2SM- PRES- speak- FV Bembe  
 “They speak Bembe.”

*Present progressive*

The progressive aspect describes an action as denoted by the verb that is ongoing at the time of speaking. One productive strategy in Bembe to express the progressive aspect is to use the progressive marker *mo-* in the usual TAM position (223).

- (223) a. *Ba- mo- kol- a.*  
 2SM PROG buy- FV  
 “They are drinking.”
- b. *Ba- mo- ly- a.*  
 2SM PROG eat FV  
 “They are eating.”

Alternatively, there exists a complex form, involving a tensed and inflected copula and a verb prefixed with the marker *mo-*, as illustrated in (224 (see also section 3.3.5.). It seems that the synthetic form in (223) is a protracted form of the complex one (224), from which the auxiliary has been dropped.<sup>13</sup>

- (224) *Ba- le mo- kol- a.*  
 2SM- COP PROG- buy- FV  
 “They are buying.”

---

13 According to Nurse (2008), “[p]rogressives deriving from locatives are the commonest type across Bantu”. He refers to research by Bastin (1989a, 1989b) who reports on a number of Bantu languages that show constructions which are derived from the sequence *li+mu+ku* (locative verb + locative prefix + verbal noun (infinitive)), which can be rendered as ‘be in/at verb-ing’.

### *Present prospective*

The prospective is used to indicate the imminent beginning of an action denoted by a verb. Heine & Kuteva (2002: 24) refer to it as “be about to verb, on the verge of verbing”. It is formed by combining a subject marker with the prospective morpheme *-oso* and an infinitival verb form.<sup>14,15</sup>

- (225) a. *N- oso o- kol- a.*  
1SG- PROS 15SM- buy- FV  
“I am about to buy.”
- b. *Ba- oso o- y- a.*  
2SM- PROS 15SM- go- FV  
“They are about to go home.”

### *General past*

The general past in Bembe is used to refer to the action of a verb that has terminated at least one day from the point of describing it. Two forms are used interchangeably: either the suffix *-ile* is added to the verb in final position, or the past tense morpheme *-lo-* is inserted in the TAM position. In the latter case, the final vowel is always *-a*. However, note that some extensions, such as the applicative, make the use of the *lo-* marker mandatory and prohibit the *-ile* form of the verb (compare (205)).

- (226) a. *Ba- Ø- koch- ile.*  
2SM- T- buy- PST  
“They bought.”
- b. *Ba- lo- kol- a.*  
2SM- PST- buy FV  
“They bought.”

---

14 It may well be the case that the morpheme *-oso* has a lexical source. However, my informants have not been able to shed any light on this issue.

15 I do not rule out the possibility that the periphrastic construction SM-*oso* + *o*-VB-*a* has grammaticalised or is still in the process of grammaticalising into the synthetic form SM-*oso*-VB-*a*, possibly triggered by contraction of the final vowel *o-* of *-oso* and the infinitive marker *o-*. However, any further comment would be speculation.

### *Near past*

The near past is used to describe events which have taken place on the same day of the utterance that makes reference to the event.

- (227) a. *Ba- a- chw- a.*  
2SM- N.PST- come- FV  
“They have (just/already) come.”

### *Far past*

The far-past verb form is used to describe events which have taken place in a more distant past. It is formed with an auxiliary verb *iba* ‘to be’ in the past tense, and the TAM marker *na-* and the final vowel *-a* on the matrix verb.

- (228) *Ba- b- ile ba- na- ly- a.*  
2SM- COP- PST 2SM- F.PST- eat- FV  
“They had eaten already.”

### *Past Perfective*

In order to express a perfective aspect of the past tense, i.e. that an action in the past has been completed, Bembe speakers make use of the verb *iwa* ‘to finish’ in connection with the inflected auxiliary verb *iba* ‘to be’ and an infinitive form of the verb.

- (229) a. *Ba- b- ile ba- a- w- a.*  
2SM- COP- PST 2SM- T- finish- FV  
(Lit.: “They had finished.”)
- b. *Ba- b- ile ba- a- w- a o- ly- a.*  
2SM- COP- PST 2SM- T- finish- FV 15SM- eat- FV  
(Lit.: “They had finished to eat”)  
“They had eaten (already).”

### *Past progressive*

In order to express the progressive aspect of a verb in the past, the auxiliary of the periphrastic form of the present progressive (cf. (224)) is inflected with the past-tense morpheme, as shown in (230). Note that the past progressive is also used to express actions that are habitually undertaken in the past (cf. (238)).

- (230) a. *Baana ba- b- ile mo- tenda- a.*  
 2child 2SM- COP- PST PROG- speak- FV  
 “The children were speaking.”

*Past prospective*

The past tense of the prospective is formed by adding the auxiliary verb *i-ba* ‘to be’, inflected with the past-tense morpheme, to the present prospective, as shown in (231) (compare also with (225)).

- (231) a. *Ni- b- ile n- oso o- te- a.*  
 1SG- COP- PST 1SG- PROS 15SM- cook-FV  
 “I was about to cook.”
- b. *Ba- b- ile ba- so o- lal- a.*  
 1SG- COP- PST 1SG- PROS 15SM- sleep- FV  
 “They were about to sleep.”
- c. *Ni-b-ile n-osso o-y-a lo-ba-hingech-ile m-ehomba.*  
 1SG-COP-PST 1SG-PROS 15SM-go-FV when-2SM-enter-PST 18LOC-9room  
 “I was about to go when they entered (into) the room.”

*Near future (Future I)*

The near future in Bembe is formed with the near future morpheme *-o-*. The forms for the second (232b) and third person singular (232c) are irregular and show portmanteau morphemes, i.e. low-toned *-ò-* for the second person singular and high-toned *-ó-* for the third person singular.

- (232) a. *N- o- tend- a.*  
 1SG- FUT-I- speak- FV  
 “I will speak.”
- b. *Ò-tend-a.*  
 2SG.FUT-I-speak-FV  
 “You will speak.”

- c. *Ó-tend-a*.  
 1SM-FUTI-speak-FV  
 “S/he will speak.”
- d. *T-o-tend-a*.  
 1PL-FUTI-speak-FV  
 “We will speak.”
- e. *M-o-tend-a*.  
 2PL-FUTI-speak-FV  
 “You will speak.”
- f. *B-o-tend-a*.  
 2SM-FUTI-speak-FV  
 “They will speak.”

There exists a second near future tense which, however, is used only when an action in the future is described as being in succession to an anterior one, in the sense of ‘and then X will do Y’. I refer to this tense as successive future. It cannot be employed in isolation, i.e. not without making reference to an anterior action. In order to form it, the future marker *shi-* is placed after the subject marker in the usual TAM position and the final vowel *-e* is suffixed, as illustrated in (233).

- (233) a. *N-o-tend-a*,            *na- shi- kemb- e*.  
 1SG-FUTI-speak-FV    1SG- S.FUT- sing- FV  
 “I will speak (and then) I will sing.”
- b. *N-o-tend-a*,            *mwa- shi- tend- e*.  
 1SG-FUTI-speak-FV    2PL- S.FUT- speak- FV  
 “I will speak (and then) you (pl.) will speak.”

*Far Future (Future II)*

The distant future tense in Bembe is formed by prefixing a high-toned marker *i-* to the verb, followed by a subject marker, as shown in the paradigm in (234).

- (234) a. *í- na- lep- a.*<sup>16</sup>  
 FUTII- 1SG- pay- FV  
 “I am going to pay.”
- b. *í- wa- lep- a.*  
 FUTII- 2SG- pay- FV  
 “You are going to pay.”
- c. *í- a- lep- a.*  
 FUTII- 1SM- pay- FV  
 “S/he is going to pay.”
- d. *í- twa- lep- a.*  
 FUTII- 1PL- pay- FV  
 “We are going to pay.”
- e. *í- mwa- lep- a.*  
 FUTII- 2PL- pay- FV  
 “You are going to pay.”
- f. *í- ba- lep- a.*  
 FUTII- 2SM- pay- FV  
 “They are going to pay.”

#### *Perfective future*

In order to express that an action will be completed in the future, Bembe speakers employ the conjugated verb *iwa* ‘to finish’ in conjunction with the far future morpheme *í-* on the copular verb and an infinitive form of the verb.

- (235) *í-na-b-a na-a-w-a o-tend-a.*  
 FUTII-1SG-COP-FV 1SG-N.PST-finish-FV 15SM-speak-FV  
 (Lit. “I am going to be I have finished to speak.”)  
 “I will have spoken.”

#### *Habitual*

The habitual refers to “a situation [...] characteristic of an extended period of time, so extended [...] that the situation [...] is viewed [...] as a characteristic feature of a whole

---

16 Alternative form: *n-na-lep-a* “I am going to pay.”

period” (Comrie 1976: 27-28). In Bembe, the habitual is formed with the habitual marker *ikyō-*. The marker is derived from the verb *i-ky-a* ‘to know’, and my informants contend that the final vowel *o* in *-ikyō-* is what used to be the infinitival marker *o-* in periphrastic constructions like (236b), which have fused into the synthetic form, which is used today, as illustrated in (236a).

- (236) a. *Ba- ikyō- tend- a.*  
 2SM- HAB- speak- FV  
 “They (habitually) speak.”
- b. *Ba-iky-a o-tend-a.*  
 2SM-know-FV 15SM-speak-FV  
 “They know to speak.”

Further examples of habitual sentences are shown in (237).

- (237) a. *Baana ba-ikyō-nyemi-w-a na mwene na εbo.*  
 2child 2SM-HAB-value-PASS-FV by 1owner of them  
 (Lit. “Children are valued by the owner of them.”)  
 “One cherishes (the value of) offspring once one has it.” (proverb)
- b. *Wetu bawambaka ta-ba-ikyō-sangan-a misea.*  
 2PL.POSS 2boy NEG-2SM-HAB-meet-FV 4girls  
 “Our boys (usually) do not meet girls.”

In order to express that an action as denoted by the verb was undertaken habitually in the past, Bembe speakers resort to the past tense form of the progressive tense.

- (238) *Ba- b- ile mo- chw- a*  
 2SM- COP- PST PROG- come- FV  
 (Lit. “They were coming.”)  
 “They (habitually) came.”

According to my language informants, speakers of the Bembe varieties spoken in Lulenge and Ngandcha (like for instance by the Basimimbi clan) make use of a dedicated habitual marker *békyak-* in conjunction with a past tense morpheme, as shown



in (239). This habitual marker, however, is not used by speakers of the Itombwe variety, the variety of Bembe described in this thesis.

- (239) *Ba- békyak- ile mo- kol- a.*  
 2SM- HAB- PST PROG- buy- FV  
 (Lit.: “They knew to buy.”)  
 “They used to buy.”

### *Persistive*

The persistive expresses that an action as denoted by the verb has been performed continuously since a certain point in time stretching to the time of the utterance. Whereas other languages have a tendency to express this aspect lexically, it is a grammatical category in Bembe and expressed via the marker *e-*.<sup>17</sup> In both present and past tense forms it is the auxiliary ‘to be’ which bears the tense morphology while the main verb is always marked for progressive aspect, as illustrated in (240) for the present tense and (241) for the past tense.

- (240) a. *To- e- le mo- tend- a.*  
 1PL- PERS-COP PROG- speak- FV  
 “We are still speaking.”
- b. *Ba- e- le mo- koch- a bitongolo.*  
 2SM- PERS-COP PROG- buy- FV 8onion  
 “They are still buying onions.”
- (241) a. *To-b-ile to-e-le mo-tend-a lw-a-ch-u-le*  
 1PL-COP-PST 1PL-PERS-COP PROG-speak-FV when-1SM-come-PST  
 “We were still speaking when he came.”
- b. *Ba-b-ile ba-e-le mo-koch-a bitongolo.*  
 2SM-COP-PST 2SM-PERS-COP PROG-buy-FV 8onion  
 “They were still buying onions.”

---

17 The persistive marker *e-* could be a reflex of Proto-Bantu *\*ki* (cf. Nurse 2008: 145). Shi (D53) employs *ci-* for the same purpose.

### *Imperative*

The imperative expresses a command. It is characterised morphologically by the absence of any subject marking, thus there is no distinction as to whether the command is directed at a single addressee or at a multitude of addressees. Examples are given in (242). Note that in some case, an epenthetic vowel is inserted at the beginning, as shown in (242c).<sup>18</sup>

- (242) a. *Tend-a!*  
speak-FV  
“Speak!”
- b. *Chw-a!*  
come-FV  
“Come!”
- c. *Ely-a!*  
eat-FV  
“Eat!”

### *Hortative*

The hortative expresses a wish or desire on part of the speaker. However, it differs from the optative insofar as it includes an appeal on part of the speaker towards the addressee to make the desire true. That is, the speaker “is encouraging or inciting someone to action” (Bybee et al. 1994: 119, 179). To form the hortative, a subject marker and the final vowel *-e* is suffixed to a verb.

- (243) a. *To-y-e o-mboka*  
2PL-go-FV 17LOC-3village  
“Let us go to the village.”
- b. *Ni-ly-e.*  
1SG-eat-FV  
“Let me eat.”

---

18 My language informants contend that speakers of the Lulenge variety of Bembe do not insert an epenthetic vowel in this case. However, I remain agnostic as to whether this is a phonological trait that delineates one Bembe variety from another, as I do not have sufficient data (other than the assertions of my informants) that could warrant such generalisations.

There exists an alternative way of politely appealing towards an addressee to make a desire true. In order to do so, Bembe speakers employ the verb *itanga* ‘to put forward’ in conjunction with an infinitive form of the verb. Importantly, this verb form is only used when an action denoted by the verb will be followed by another action. Note that the final vowel is *a-* and not *e-*, as in the primary hortative verb-form.

- (244) a. *To-tang-a*                      *o-lya*.  
           2PL-put.forward-FV    15SM-eat  
           (Lit. “We put forward to eat”.)  
           “Let us eat (first).”
- b. *Ni-tang-a*                      *o-o-toch-a*.  
           1SG-put.forward-FV    15SM-2SG.OM-ask-FV  
           (Lit. “I put forward to ask you.”)  
           “Let me ask you (something first).”

#### *Optative*

The optative expresses a wish or desire on part of the speaker. However, it differs from the imperative and hortative insofar as it does not include an appeal on part of the speaker towards the addressee to make the desire true. In order to form the optative in Bembe, the conditional marker *na-* and the successive-future tense marker *shi-* combine, and appear with a second, infinitival verb form.

- (245) a. *O-na-shi-ile*                      *o-lo-a*.  
           15EXPL-POT-S.FUT-PST    15SM-rain-FV  
           (Lit. “If it would will have to rain.”)  
           “If (only) it would rain.”
- b. *O-na-shi-ile*                      *o-ly-a*.  
           2SG-POT-S.FUT-PST    15SM-eat-FV  
           (Lit. “If you would have will have to eat.”)  
           “If (only) you would eat.”

In order to express a wish or desire in the past, the main verb form and the past tense morpheme *-ile* in final position are suffixed to the optative verb-form.

- (246) a. *O-na-shi-lo-ile.*  
 15EXPL-POT-S.FUT-rain-PST  
 “If (only) it would have rained.”
- b. *O-na-shi-l-ile.*  
 2SG-POT-S.FUT-eat-PST  
 “If (only) you would have eaten.”
- c. *Ba-na-shi-tend-ile.*  
 2SM-POT-S.FUT-speak-PST  
 “If (only) they would have spoken.”

### 2.3.3.2 Non-affirmative conjugations

This section illustrates the negated forms of the conjugations presented in section 2.3.3.1.

#### *General present*

Negated forms of the general present are formed with the negation marker *ta-*. For the first person singular, however, the negation marker *sha-* is employed.

- (247) a. *Ta-twa-a-kol-a*      *bibemba.*  
 NEG-1PL-N.PST-buy-FV 8pumpkin  
 “We do not buy (any) pumpkins.”
- b. *Sha-a-kemb-a.*  
 NEG-PRES-sing-FV  
 “I do not sing.”
- c. *Ta-ba-a-kemb-a.*  
 NEG-2SM-PRES-sing-FV  
 “They do not sing.”

#### *Present progressive*

The present progressive verb-form is negated by prefixing the negation marker *ta-* to the stem of the synthetic verb-form, as shown in (248), or to the stem of the auxiliary verb in the periphrastic construction, as in (249).

- (248) a. *Ta-na-mo-lep-a.*  
 NEG-1SG-PROG-pay-FV  
 “I am not paying.”
- b. *Ta-ba-mo-kol-a.*  
 NEG-2SM-PROG-buy-FV  
 “They are not buying.”

- (249) a. *Ta-ba-le mo-sol-a.*  
 NEG-2SM-COP PROG-drink-FV  
 “They are not drinking.”
- b. *Ta-ba-le mo-o-ly-a.*  
 NEG-2SM-COP PROG-15SM-eat-FV  
 “They are not eating.”

*Present Prospective*

Negated forms of the present prospective take the *ta-* negation marker, except for the first person singular, which shows the portmanteau morpheme *shi-* and which encodes first person singular and negation, as shown in (250).

- (250) a. *Shi-so o-tend-a.*  
 NEG.1SG-PROS 15SM-speak-FV  
 “I am not about to speak.”
- b. *Ta-ba-so o-tend-a.*  
 NEG-2SM-PROS 15SM-speak-FV  
 “They are not about to speak.”

*General past*

Negated forms of the general past take the *ta-* negation marker, except for the first person singular, which shows the portmanteau morpheme *sha-* and encodes first person singular and negation, as illustrated in (251).

- (251) a. *Sha-mon-ine ewe.*  
 NEG.1SG-see-PST him  
 “I did not see him.”

- b. Ta- ba- lo- kol- a mleka.  
 NEG- 2SM- PST- buy FV 3beans  
 “They did not buy (any) beans.”

*Near past*

The near-past tense is negated with the *ta-* negation marker. For the first person singular, negation and person are expressed by the portmanteau morpheme *sha-*.

- (252) a. Sha-a-tend-a.  
 NEG.1SG-N.PST-speak-FV  
 “I have not spoken.”
- b. Ta-twa-a-kol-a etabo.  
 NEG-1PL-N.PST-buy-FV 7book  
 “We have not bought any book.”

*Far past*

The far-past tense is negated by prefixing the negation marker *ta-* to the inflected auxiliary verb.

- (253) Ta-ba-b-ile ba-na-ly-a.  
 NEG-2SM- COP -PST 2SM-F.PST-eat-FV  
 “They had not eaten (yet).”

*Past Perfective*

The past-perfective tense is also negated by prefixing the negation marker *ta-* to the inflected auxiliary verb.

- (254) Ta-ba-b-ile ba-na-w-a o-ly-a.  
 NEG-2SM-COP-PST 2SM-F.PST-finish-FV 15SM-eat-FV  
 (Lit. “They had not finished to eat.”)  
 “They had not eaten (yet).”

*Past progressive*

The past-progressive tense is negated by prefixation of the negation marker *ta-* to the auxiliary verb.

- (255) Ta-ba-b-ile      mo-tend-a.  
 NEG-2SM-COP-PST PROG-speak-FV  
 “I was not speaking.”

*Past Prospective*

The past prospective tense is negated with the *ta-* negation marker on the auxiliary verb. For the first person singular, negation and person are expressed by the portmanteau morpheme *shi-*.

- (256) a. Shi-      b-      ile    n-      oso      o-      te-    a  
 1SG.NEG- COP-    PST    1SG    PROS      15SM- cook-FV  
 “I was not about to cook.”
- b. Ta-    ba-    b-      ile    ba-    so      o-      lal-    a.  
 NEG- 2SM- COP- PST    2SM- PROS      15SM- sleep- FV  
 “They were not about to sleep.”

*Near Future (Future I)*

The negated form of the near-future tense is expressed with the negation marker *ta-*, as illustrated in the examples in (257). Note that in the first person singular, the portmanteau morpheme *sh-* simultaneously expresses the grammatical categories of negation and person/number.

- (257) a. Sh-o-kemb-a.  
 NEG.1SG-FUTI-sing-FV  
 “I will not sing.”
- b. Ta-ò-kemb-a.  
 NEG-2SG.FUTI-sing-FV  
 “You will not sing.” (sg.)
- c. Ta-ó-kemb-a.  
 NEG-1SM.FUTI-sing-FV  
 “S/he will not sing.”

- d. *Ta-to-kemb-a*.  
 NEG-1PL.FUTI-sing-FV  
 “We will not sing.”
- e. *Ta-mo-kemb-a*.  
 NEG-2PL.FUTI-sing-FV  
 “You will not sing.” (pl.)
- f. *Ta-bo-kemb-a*.  
 NEG-2PL.FUT-sing-FV  
 “They will not sing.”

#### *Successive Future*

The negated form of the successive-future tense is expressed with the *ta-* negation morpheme. The first person singular, however, shows the portmanteau morpheme *shi-*, which encodes negation and person.

- (258) a. ... *shiéta shi-shi-kemb-e*.  
 but NEG.1SG-S.FUT-sing-FV  
 “... but (then) I am not going to sing.”
- b. ... *shiéta ta-ba-shi-kemb-e*.  
 but NEG-2SM- S.FUT-sing-FV  
 “... but (then) they are not going to sing.”

#### *Present Habitual*

The present-habitual verb-form is negated by prefixation with the negation marker *ta-*.

- (259) *Bitabo ta-bi-ikyo-nyemi-w-a na mwene na ebyo*.  
 8book NEG-8SM-HAB-value-PASS-FV by 1owner of them  
 (Lit. “Books are not valued by the owner of them.”)  
 “One does not cherish (the value of) books once one has them.”



### *Past Habitual*

In order to refer to an action that has been performed habitually, Bembe speakers resort to the past-progressive form (cf. (255)) instead of a dedicated past-habitual verb-form. The same is valid for negated past-habitual verb-forms.<sup>19</sup>

- (260) *Ta-ba-b-ile mo-kol-a.*  
NEG-2SM-COP-PST PROG-buy-FV  
“They did not (habitually) buy.”

### *Present Persistent*

The negated form of the present persistent is formed by prefixing the negation marker *ta-* to the auxiliary verb bearing the persistent marker *e-*. In addition, the morpheme *na-* appears on the matrix verb.

- (261) *Ta- ba- e- le ba- na- tend- a.*  
NEG- 2SM- PERS- COP 2SM- POT- speak- FV  
“They are still not speaking.”

### *Past Persistent*

The negated form of the past persistent tense is formed by prefixing the negation marker *ta-* to the inflected auxiliary verb. In addition, the morpheme *na-* appears on the matrix verb.

- (262) *Ta- ba- b- ile ba- na- mo- tend- a*  
NEG- 2SM- COP- PST 2SM- POT PROG- speak- FV  
“They were still not speaking.”

---

19 In analogy to the affirmative form (cf. (239)), speakers of the Bembe varieties spoken in Lulenge and Ngandcha (like for instance the Basimimbi clan) make use of a dedicated habitual marker *békyak-* in conjunction with a past tense morpheme and a negative morpheme *ta-*, as shown in (i). This habitual marker, however, is not used by speakers of the Itombwe variety, the variety of Bembe described in this thesis.

(i) *Ta-ba-békyak-ile mo-kol-a.*  
NEG-2SM-HAB-PST PROG-buy-FV  
(Lit.: “They used to buying.”)  
“They did not used to buy.”

### *Imperative*

Negated imperatives (prohibitives) are formed by prefixing the negation morpheme *ta-* to an imperative form. As opposed to the affirmative form, negated imperatives display a second person singular or plural subject marker, in order to differentiate whether the command is directed at a single person or at a multitude of people. Note that, in contrast to affirmative imperative verb forms, prohibitives are additionally suffixed with the final vowel *-e*.

- (263) a. *Ta-o-tend-e!*  
NEG-2SG-speak-FV  
“Do not speak!” (sg.)
- b. *Ta-o-lwal-e!*  
NEG-2SG-get.sick-FV  
“Do not get sick!” (sg.)
- c. *Ta-mu-tend-e!*  
NEG-2PL-speak-FV  
“Do not speak.” (pl.)

### *Hortative*

In order to form the negated form of a hortative verb form, the negation morpheme *ta-* is added in pre-initial position to the stem of the verb.

- (264) *Ta-to-y-e*      *o-mboka*.  
NEG-2PL-go-FV    17LOC-9village  
“Let us not go to the village!”

The alternative hortative form which employs the verb *itanga* ‘to put forward’ (cf. (244)) cannot be negated.

### *Present Optative*

To form the negative form of the present optative tense, the negation morpheme *ta-* is prefixed to the verb bearing the potential and future marker.

- (265) *Ta-o-na-hi-le*                      *o-lo-a.*  
 NEG-15EXPL-POT-FUT-?    15SM-rain-FV  
 “If only it would not rain.”

*Past Optative*

The past optative tense is formed by prefixing the negation marker *ta-* and the past-tense marker *-ile* to the verb.

- (266) a. *Ta-o-na-lo-ile.*  
 NEG-15EXPL-POT-rain-PST  
 “If (only) it would not have rained.”
- b. *Ta-o-na-l-ile.*  
 NEG-2SG-POT-eat-PST  
 “If (only) you would not have eaten.”
- c. *Ta-ba-na-tend-ile.*  
 NEG-2SM-POT-speak-PST  
 “If (only) they would not have spoken.”

Table 26 summarises the Bembe tense and aspect system.

Tense	Example
<u>PRESENT</u>	
General present	<i>Ba- a- tend- a Bembe.</i> 2SM- T- speak- FV Bembe “They speak Bembe.”
Present progressive	a. <i>Ba- le mo- kol- a.</i> 2SM- be PROG- buy- FV ‘They are drinking.’
	b. <i>Ba- mo- kol- a.</i> 2SM PROG buy FV ‘They are drinking.’

Potential present	<p><i>Ba- <u>na-</u> bal- w- a.</i>  14SM- POT- count- PASS- FV  “It can/would be counted.”</p>
Prospective present	<p><i>N(i)- <u>oso-</u> kol- a.</i>  1SG- PROS- buy- FV  “I am about to buy.”</p>
Optative present	<p><i>O- <u>na-</u> <u>shi-</u> ile <u>o-</u> lo- a.</i>  15EXPL- POT- S.FUT- PST 15SM- rain- FV  “If only it would rain.”</p>
Habitual present	<p><i>B(a)- <u>ikyo-</u> kol- a.</i>  2SM- HAB- buy- FV  (Lit. “They know to drink.”)  “They (usually) drink.”</p>
Persistive present	<p><i>Ba- <u>e-</u> le <u>mo-</u> tend- a</i>  2SM- PERS-COP PROG- speak- FV  “They are still speaking.”</p>

PAST

General past	a.	<p><i>Ba- ∅ kol- <u>ile</u> .</i>  2SM- T buy- PST  “They bought.”</p>
	b.	<p><i>Ba- <u>lo-</u> kol- a</i>  2SM- PST- buy FV  “They bought.”</p>
Near past		<p><i>Ba- <u>a</u> chw- <u>a</u>.</i>  2SM- N.PST- come FV  “They have (just) come.”</p>
Far past		<p><i>Ba- b- <u>ile</u> ba- <u>na-</u> ly- a</i>  2SM- COP- PST 2SM F.PST eat FV  “They had eaten.”</p>

Past perfective	<p><i>Ba- b- <u>ile</u> ba- w- a o- ly- a</i>  2SM- COP- PST 2SM- finish- FV 15SM- eat- FV  (Lit. “They were finished eating”)  “They had (already/just) finished.”</p>
Past Progressive	<p><i>Ba- b- <u>ile</u> mo- kol- a.</i>  2SM- COP-PST PROG- buy- FV  “They were buying.”</p>
Optative past	<p><i>O- na- <u>shi-</u> l- <u>ile.</u></i>  2SG- POT- S.FUT- eat- PST  “If (only) you would have eaten.”</p>
Potential past	<p><i>Ba- na- chw- ile.</i>  2SM- POT- come- PST  “They could/would have arrived.”</p>
Prospective past	<p><i>Ba- b- <u>ile</u> ba- so o- lal- a.</i>  2SM- COP- PST 1SG- PROS 15SM- sleep- FV  “They were about to sleep.”</p>
Habitual past	<p><i>Ba- b- <u>ile</u> mo- kol- a.</i>  2SM- COP- PST PROG-buy- FV  (Lit. “They were buying.)  “They used to buy.”</p>
Persistent past	<p><i>Ba- b- <u>ile</u> ba- e- le mo- tend- a</i>  2SM- COP- PST 2SM- PERS-COP PROG- speak- FV  “They were still speaking.”</p>
<u>FUTURE</u>	
Near future (I)	<p><i>B- o- tend- a.</i>  2SM- FUT-I- speak- FV  “They will speak.”</p>
Successive future	<p><i>Ba- <u>shi-</u> kemb- e.</i>  2SM S.FUT- sing- FV  “(And then) they will sing.”</p>

Distant future (II)	<i>í- ba- a- kol- a</i> FUTII- 2SM- T- buy- FV “They are going to buy.”
Future Perfective	<i>Ba- ob- a ba- w- a o- kol- a.</i> 2SM- will- FV 2SM- finish- FV 15SM- drink- FV (Lit. “They will have finished to drink.”) “They will have drunk.”
OTHER FORMS	
Imperative	<i>Tend- a!</i> speak- FV “Speak!”
Hortative I	<i>To- y- e!</i> 2PL- go- FV “Let us go!”
Hortative II	<i>To- tang- o o- ly- a</i> 2PL- put.forward- FV 15SM- eat- FV “Let us eat.”

Table 26: THE BEMBE TENSE & ASPECT SYSTEM

#### 2.3.4 Adverbs

Adverbs are words or phrases that modify the meaning of an adjective, a verb or another adverb, expressing time, probability, manner or place. The dataset contains adverbs of time, probability, manner and location, as well as conjunctive and degree adverbs.

##### *Adverbs of time*

The following list shows the Bembe adverbs used to specify at what point in time an event has taken or will take place. Note that the meanings of the adverbs *ndele* and *ahete*, i.e. whether they are used with reference to past or future events, are determined by the tense of the verb.

<i>ndeke</i>	‘the day before the day before yesterday’ (3 days ago)
<i>ahete</i>	‘the day before yesterday’ (2 days ago)
<i>elya ekolo</i>	‘yesterday’ (lit. ‘that evening’)
<i>lono lusuku</i>	‘today’ (lit. ‘this day’)
<i>mmeshi</i>	‘tomorrow’
<i>ahete</i>	‘the day after tomorrow’ (in 2 days)
<i>ndeke</i>	‘the day after the day after tomorrow’ (in 3 days)

#### *Adverbs of probability*

Adverbs of probability signal how certain the speaker of an utterance is about the likelihood of an event.

<i>hika</i>	‘probably’
<i>hange</i>	‘maybe’

#### *Manner adverbs*

The manner adverbs found in the dataset are exclusively formed by reduplication and find their derivative source in either numerals, adjectives or demonstratives. They are listed in Table 27.

<i>omo.omo</i>	‘one at a time’ (< <i>-mo</i> ‘one’)
<i>boni.boni</i>	‘slowly’ (< <i>boni</i> ‘slow’)
<i>lobelo.lobelo</i>	‘quickly’ (< <i>lobelo</i> ‘early’)
<i>bilya.bilya</i>	‘likewise, also’ (< <i>bilya</i> ‘that’)
<i>to’o.to’o</i>	‘very red’ (< <i>toola</i> ‘redness’)
<i>kasa.kasa</i>	‘openly’
<i>bene.bene</i>	‘true’ (< <i>bene</i> ‘else’)

Table 27: MANNER ADVERBS RESULTING FROM REDUPLICATION

#### *Adverbs of location*

There are six locative adverbs, three of which signal the direction in which an object is moving, and three which signal its position. It seems that the directional locative adverbs have their derivational source in the class 17 locative marker *o-*, whereas the positional locative adverbs have their derivational source in the class 16 locative marker

a-. Like demonstratives, a three-way distinction is made on the basis of the proximity of the object with regard to the speaker. Table 28 illustrates the locative adverbs.

Type	<i>Proximal</i>	<i>Medial</i>	<i>Distal</i>
Direction	<i>ono</i> ‘here’	<i>oo</i> ‘yonder there’	<i>olya</i> ‘there’
Position/location	<i>hano</i> ‘here’	<i>hao</i> ‘yonder there’	<i>halya</i> ‘there’

Table 28: LOCATIVE ADVERBS

The following examples in (267) illustrate the usage of locative adverbs.

- (267) a. *Echw-a o-no!*<sup>20</sup>  
 come-FV 17LOC-DEM.prox  
 “Come here!”
- b. *Iddi a-a-ch-w-a o-no, a-le ha-no.*  
 1Iddi 1SM-N.PST-come-FV 17LOC-DEM.prox 1SM-COP 16LOC-DEM.prox  
 “Iddi has come here, he is here.”
- c. *Twa-k-ile o-lya.*  
 1PL-go-PST 17LOC-DEM.dist  
 “We went over there.”

*Linking/conjunctive adverbs (na ‘too’, ‘also’)*

In order to express the idea that a participant has performed an action in addition to another action (268a-b) or the same action in addition to another person (268c-d), the conjunctive adverb *na* is used. (268c) shows how a reduplicated class-8 demonstrative can be used as an alternative to *na* ‘with’.

- (268) a. *Iddi na ewe a-a-chw-a. / Iddi na ake a-a-chw-a.*  
 1Iddi with he 1SM-N.PST-come-FV 1Iddi with his 1SM-N.PST-come-FV  
 “Iddi has also come.”
- b. *Na ine, na-a-chw-a / Na ane na-a-chw-a.*  
 With I 1SG-N.PST-come-FV With my 1SG-N.PST-come-FV  
 “I have come, too.”

20 Note that insertion of the prefix *e-* (epenthesis) to the verb root *-chw-a* creates an irregular verb form, as imperatives in Bembe are generally characterised by the absence of any prefixes.



- c. *Ali bilya-bilya/biby biyo/bino bino/na a-soch-ile*  
 1Ali that that/yonder yonder/this this/with 1SM-drink-PST  
*maonde mose.*  
 6alcoholic drink 6all  
 (Lit.: “Ali that that drank all the alcoholic drinks”.)  
 “Ali also drank all the alcoholic drinks.”
- d. *Ali na a-soch-ile maonde mose.*  
 Ali with 1SM-drink-PST 6alcoholic drink 6all  
 (Lit.: “Ali and drank all the alcoholic drinks”.)  
 “Ali also drank all the alcoholic drinks.”

*Degree adverb manga* ‘very’

The adverb *manga* is used to emphasise that a quality is true to a great degree. The examples below show that *manga* can modify stative verbs (269a-b) and connective constructions used for adjectival modification of nominals (269c). It always follows the element it modifies.

- (269) a. *A-a-feel-a manga.*  
 1SM-PRES-be.short-FV much  
 (Lit. “S/he is short much.”)  
 “S/he is very short.”
- b. *A-a-le-a manga.*  
 1SM-PRES-be.tall-FV much  
 (Lit. “She is tall much.”)  
 “S/he is very tall.”
- c. *Msonga o-b-ile wa ngene manga.*  
 3porridge 3SM-COP-PST 3CONN goodness many  
 “The porridge was very good.”

Interestingly, other degree adverbs, such as to describe the quality expressed by a noun-modifying element or the action denoted by a verb, as being ‘more than sufficient or useful’ (Eng. ‘too’) or as being ‘fulfilled to a necessary degree’ (Eng. ‘enough’) are not available in Bembe.

## 2.4 The syntax of clauses

### 2.4.1 Simple declarative clauses

Given that Bembe is a pro-drop language and the subcategorisation requirements of the verbs are satisfied by means of pre- and suffixation, the presence of a verb constitutes the necessary and sufficient condition to form a declarative sentence in Bembe. As we have already seen, in simple declaratives, the verb is always marked with a corresponding subject marker and, if necessary, an object (or reflexive) marker. Note that the term verb marking is used rather widely without deciding on the question whether subject and object markers are agreement or pronominal morphology. This question will be dealt with in detail in Chapters 3 and 4.

(270) a. *Na-bi-koch-ile.*

1SG-8OM-buy-PST

“I bought it.”

b. *Ta-ba-a-hi-chic-a.*

NEG-2SM-N.PST-REF-bite-FV

“They have not bitten themselves.”

Like other Bantu languages, the basic word order is (S) V (AI) (IO) (DO) (X<sub>1</sub>, X<sub>2</sub>, X<sub>3</sub>) (where each X stands for an adjunct or oblique), as shown in (271). The order of adjuncts is flexible, however, (271a) illustrates the unmarked alternative, in which locative elements precede temporal expressions.

(271) a. *Bawambaka ba-koch-ile bilewa o-soo elya ekolo.*

2boy 2SM-buy-PST 8food 17LOC-market 7DEM.dist 7night

“The boys bought food at the market yesterday.”

b. *Bawambaka ba-koch-ile bilewa elya ekolo o-soo.*

2boy 2SM-buy-FV 8food 7DEM.dist 7night 17LOC-market

“The boys bought food at the market yesterday.”

In ditransitive sentences, arguments are always ordered in such a way that the goal/recipient object (indirect object) always precedes the theme object (direct object), as illustrated in (272a). (272b) shows that the same is valid for applicative

constructions, as applied (benefactive) arguments always precede theme objects (direct objects). Arguments of applied ditransitive verbs are always ordered in such a way that the applied (benefactive) argument precedes the indirect (goal/recipient) object, which in turn precedes the direct (theme) object, as illustrated in (272c).

- (272) a. *Bawambaka ba-h-ile misea bilewa elya ekolo.*  
 2boy 2SM-give-PST 4girls 8food 7DEM.dist 7night  
 “The boys gave the girls food yesterday.”
- b. *Bawambaka ba-lo-kol-el-a lobonga bilewa.*  
 2boy 2SM-PST-buy-APPL-FV 11church 8food  
 “The boys bought food on behalf of the church.”
- c. *Bawambaka ba-lo-h-el-a lobonga misea bilewa.*  
 2boy 2SM-PST-give-APPL-FV 11church 4girls 8food  
 “The boys gave the girls food on behalf of the church.”

The ordering of objects in ditransitive, applicative and applied ditransitive sentences in Bembe is summarised in Table 29.

		Benefactive (AI)	Goal/recipient (IO)	Theme (DO)
Ditransitive	<i>Ba-h-ile</i>	-	<i>misea</i>	<i>bilewa</i>
Applicative	<i>Balo-kol-el-a</i>	<i>lobonga</i>	-	<i>bilewa</i>
Ditransitive applicatives	<i>Balo-h-el-a</i>	<i>lobonga</i>	<i>misea</i>	<i>bilewa</i>

Table 29: ORDERING OF OBJECT ARGUMENTS

Adverbs of time can appear either in sentence-initial or sentence-final position, or in immediate pre-verbal position, as shown in (273).

- (273) (*Elya ekolo*) *Ali (elya ekolo) a-soch-ile makye*  
 7DEM.dist 7night 1Ali 7DEM.dist 7night 1SM-drink-PST 6water  
*(elya ekolo).*  
 7DEM.dist 7night  
 “(Yesterday) Ali (yesterday) drank water (yesterday).”

Manner adverbs, in turn, can only appear immediately after the verbs they modify, as illustrated in (274).

- (274) *Ali a-soch-ile boni.boni makyé.*  
 1Ali 1SM-drink-PST slow.slow 6water  
 “Ali slowly drank (some) water.”

#### 2.4.2 Relative clauses

For the sake of clarity and systematicity, I present the word order and verb-marking facts in the domain of relative-clause formation for subjects and non-subjects separately.

##### *Subject relative clauses*

In subject relative clauses, the subject marker is absent and replaced by a relative marker that agrees with the relativised subject. Although for the majority of noun classes, the relative markers do not differ morphologically from their subject marker counterparts, there is reason to assume that we are dealing with two distinct sets of morphemes. Consider the contrast with nouns belonging to class 1, as shown in (275a-b).

- (275) a. *Mtu wa-yak-ilé ngyo?a ta-a-b-ile na bolema*  
 1person 1REL-kill-PST 9snake NEG-1SM-COP-PST with 14stupidity  
 “The person who killed the snake was not stupid.”
- b. *Mtu a-yak-ile ngyo?a.*  
 1person 1SM-kill-PST 9snake  
 “The person killed the snake.”

Nouns of class 1, which usually mark the verb with the class 1 marker *a-* in non-relative contexts, mark the verb with *wa-* in relative contexts. Relative-marking morphology is thus different from subject-marking morphology.

Relativised verbs in general display a difference in tone compared to non-relativised ones: while in non-relative contexts the tone on the verb-final syllable is low, it is raised to a high tone in relative clauses. Consider the contrast between (276a-b) & (276c-d).

- (276) a. *Ngoyo?a ya-a-yak-a tonyoni.*  
 9snake 9SM-N.PST-kill-FV 13bird  
 “The snake has killed the birds.”
- b. *Ngoyo?a ya-a-yak-á tonyoni ya-b-ile ya mmolo.*  
 9snake 9REL-N.PST-kill-FV 13bird 9-COP-PST 9CONN bigness  
 “The snake which has killed the birds was big.”
- c. *Mlumyana a-koch-ile mlonge.*  
 1woman 1SM-buy-PST 3bamboo  
 “The woman bought (some) bamboo.”
- d. *Mlumyana wa-koch-ilé mlonge a-le mboka wane.*  
 1woman 1REL-buy-PST 3bamboo 1SM-COP 1neighbour 1SG.POSS  
 “The woman who bought the bamboo is his/her neighbour.”

While we have already seen that subjects of transitive verbs can undergo relativisation and thus relative-mark the verb, we have not yet said anything about intransitive verbs. This type of verbs can be further sub-divided into two sub-types: unaccusative and ergative verbs. The difference between the two is that exponents of the former sub-type lack an external argument but have an internal argument, while the members of the latter sub-type have an external argument but lack an internal argument. However, there is no morphological or syntactic difference between the relativisation of ergative subjects and that of unaccusative subjects, as both can be relativised and induce relative verb-marking alike, as illustrated in (277) and (278), respectively.

- (277) a. *Ebi ?ya-bele-ile.*  
 7door 7SM-break-PST  
 “The door broke.”
- b. *ebi ?ya-bele-ilé.*  
 7door 7REL-break-PST  
 “the door that broke”
- c. *Eno i-ebi ?ya-bele-ilé.*  
 7DEM.prox ?-7door 7SM-break-PST  
 “This is the door that broke.”

d. *E-le ebi i-ya-bele-ilé.*  
 7SM-COP 7door FOC-7SM-break-PST  
 “It is the door that broke”

(278) a. *Mwana a-a-ɔw-a.*  
 1child 1SM-N.PST-die-FV  
 “The child has died.”

b. *mwana wa-a-ɔw-á*  
 1child 1REL-N.PST-die-FV  
 “the child that has died”

c. *A-le mwana i-wa-a-ɔw-á.*  
 1SM-COP 1child FOC-1REL-N.PST-die-FV  
 “It is the child that has died.”

#### *Object relative clauses*

In analogy to subject relatives, the subject marker in object relative clauses is absent and replaced by a relative marker that always agrees with the relativised object (279a-b).

(279) a. *Baana ba-mon-ilé Iddi ba-b-ile babembe.*  
 2child 2REL-see-PST 1Iddi 2SM-COP-PST 2Bembe  
 “The children which Iddi saw were Bembe.”

b. *bilewa bya-koch-ilé baana*  
 8food 8REL-buy-PST 2child  
 “the food that (some) children bought”

The tonal pattern of relativised verbs in object relatives mimics that found in subject relatives, i.e. the final syllable bears a high tone instead of a low one found in declaratives. Consider the contrast between (280a & b).

(280) a. *Ngwoɔa ya-na-a-yak-á ya-b-ile ya mmolo.*  
 9snake 9REL-1SG-N.PST-kill-FV 9SM-COP-PST 9CONN bigness  
 “The snake which I have just killed was big.”

- b. *Na-a-yak-a*      *ngyoʔa*.  
 1SM-N.PST-kill-FV 9snake  
 “I have just killed a snake.”

With respect to word order, a lexical subject can only appear in postverbal position (281a-b) and cannot ever precede the verb (281c-d) in object relatives.

- (281) a. *Baana ba-mon-ilé Iddi ba-b-ile babembe*.  
 2child 2REL-see-PST 1Iddi 2SM-COP-PST 2Bembe  
 “The children which Iddi saw were Bembe.”
- b. *bilewa bya-koch-ilé baana*  
 8food 8REL-buy-PST 2child  
 “the food that (some) children bought”
- c. \**Baana Iddi ba-mon-ilé ba-b-ile babembe*.  
 2child 1Iddi 2REL-see-PST 2SM-COP-PST 2Bembe  
 (Int. “The children which Iddi saw were Bembe.”)
- d. \**bilewa baana ba-koch-ilé*  
 8food 2child 2REL-buy-PST  
 (Int. “the food that (some) children bought”)

However, it is interesting to note that all language consultants agree in that they prefer to passivise the verb and express the subject in a by-phrase instead of having an active verb with a postverbal subject, as in (281). The preferred constructions are shown in (282).

- (282) a. *Baana ba-lo-mon-w-á na Iddi ba-b-ile babembe*.  
 2child 2REL-PST-see-FV by 1Iddi 2SM-COP-PST 2Bembe  
 “The children which have been seen by Iddi were Bembe.”
- b. *bilewa bya-a-kol-w-á na baana*  
 8food 8REL-N.PST-buy-PST by 2child  
 “the food that has been bought by (some) children”

As with other inversion constructions in Bembe, a subject marker is not allowed on the verb in conjunction with postverbal lexical subjects (283a-b).

- (283) a. \**Baana ba-ba-mon-ilé baboka ba-b-ile babembe.*  
 2child 2REL-2SM-see-PST 2neighbour 2SM-COP-PST 2Bembe  
 (Int. “The children which (some) neighbours saw were Bembe.”)
- b. \**bilewa bi-ba-koch-ilé baana*  
 8food 8REL-2SM-buy-PST 2child  
 (Int. “the food that (some) children bought”)

However, if the lexical subject is omitted, a subject marker, co-referential in class with the omitted subject, obligatorily figures on the verb, following the relative marker. I will refer to this construction with covert subjects as Type 1 object relatives. In contrast, object relatives with overt postverbal subjects I will refer to as Type 2 object relative. Consider (284).

- (284) a. *Baana ba-twa-mon-ilé ba-b-ile babembe.* [Type 1 object relative]  
 2child 1REL-1PL-see-PST 2SM-COP-PST 2Bembe  
 “The children which we saw were Bembe.”
- b. *bilewa bi-ba-koch-ilé*  
 8food 8REL-2SM-buy-PST  
 “the food that they bought”

As far as object marking is concerned, replacing a relativised object with an object marker is completely ungrammatical, as shown in (285).

- (285) a. \**Baana ba-ba-mon-ilé Iddi ba-b-ile babembe.*  
 2child 2REL-2OM-see-PST 1Iddi 2SM-COP-PST 2Bembe  
 (Int. “The children which Iddi saw were Bembe.”)
- b. \**bilewa bya-bi-koch-ilé baana*  
 8food 8REL-8OM-buy-PST 2child  
 “the food that (some) children bought”

The ungrammaticality of object marking however only holds in the case of relativised objects. This is illustrated in (286), where the direct object, which is not the head of the relative clause, can either be taken up by the corresponding lexical pronoun (286a) or



alternatively be object-marked (286b). It is however not possible to object-mark the pronoun that cross-references the non-relativised object in ditransitive sentences either, as shown in (286c).

- (286) a. *Mtu o-ba-h-ilé bibyo a-a-y-a.*  
 1man 1REL-2SM-give-PST 8DEM 1SM-N.PST-leave-FV  
 “The man to whom they gave it (the food) has left.”
- b. *Mtu o-ba-bi-h-ile a-a-y-a.*  
 1man 1REL-2SM-8OM-give-PST 1SM-N.PST-leave-FV  
 (Int. “The man to whom they gave it (the food) has left.”)
- c. \**Mtu o-ba-m-h-ile ewe bilewa a-a-y-a.*  
 1person 1REL-2SM-1OM-give-PST him 8food 1SM-N.PST-leave-FV  
 (Int. “The person to whom they gave the food has left.”)

#### *Locatives*

Locative nouns can be relativised, in which case they induce relative marking on the verb.

- (287) a. *m-numba mwa-a-ly-á baana*  
 18LOC-9house 18REL-N.PST-eat-FV 2child  
 “in the house in which/where children eat”
- b. *m-numba mu-lé bosasa.*  
 18LOC-9house 18REL-COP dirty  
 “in the house in which it is dirty”
- c. *Ta-ba-iky-e o-le lokye lo-twa-so-ile.*  
 NEG-2SM-know-FV 17SM-be 1river 11REL-1PL-cross-PST  
 “They do not know where the river that we crossed is.”
- d. *Lobonga lo-ni-b-ile mo-hon-en-a hemo*  
 11church 11REL-1SG-COP-PST PROG-pray-APPL-FV inside  
*lo-b-ile kwa mmolo.*  
 11SM-COP-PST 11CONN bigness  
 (Lit. “The church which I was praying inside was big.”)  
 “The church in which I was praying was big.”

- e. *Lɔkolo lo-n-ikyo-hɛl-a lo-le bole.*  
 11mountain 11REL-1SG-HAB-climb-FV 11SM-COP far  
 “The mountain which I usually climb (up) is (too) far (away).”

*Prepositional instrumentals*

As already shown in the discussion of the applicative extension *el-* above, Bembe does not use the applicative but rather resorts to prepositional instrumentals in order to express that an action has been performed with the help of an instrument. Prepositional instrumentals seem to contain a resumptive pronoun, co-referential in class with the relativised element, in addition to the relative marker on the verb.

- (288) a. *poso e-twa-bétch-ilé n(a) ɛyɔ ebi*  
 9axe 9REL-1PL-smash-PST with 9it 9door  
 “the axe with which we smashed the door”
- b. *mwele o-na-bémb-ilé n(a) ɛyɔ nyama*  
 3knife 3REL-1SG-cut-PST with 3it 9meat  
 “the knife with which I cut the meat”
- c. *hibwe le-na-yak-ilé n(a) ɛlyɔ eswe*  
 5stone 5REL-1SG-kill-PST with 5it 7fish  
 “the stone with which I killed the fish”

Object marking of objects in relative clauses which are headed by a locative copula (289a) and in resumptive relative clauses headed by a preposition (289b) always results in ungrammaticality.

- (289) a. *\*Ta-ba-iky-e o-le lokye lo-twa-lo-so-ilé.*  
 NEG-2SM-know-FV 17SM-be 11river 11REL-1PL-11OM-cross-PST  
 (Int. “They do not know where the river that we crossed is.”)
- b. *\*poso e-twa-ya-bech-ilé n(a) ɛyɔ ebi*  
 9axe 9REL-1PL-9OM-smash-PST with 9it 9door  
 (Int. “the axe with which we smashed the door”)

### 2.4.3 Cleft sentences

Lambrecht (2001: 467) defines a cleft construction as “a complex sentence structure consisting of a matrix clause headed by a copula and a relative or relative-like clause whose relativized argument is co-indexed with the predicative argument of the copula. Taken together, the matrix and the relative express a logically simple proposition, which can also be expressed in the form of a single clause without a change in truth conditions.” Cleft sentences in Bembe consist of a subject, object or oblique DP made predicative by a copula and followed by a relative clause. The copula agrees with the clefted element. Additionally, the relative verb within the relative clause is prefixed with an invariable prefix *i-*, occupying what seems to be the pre-pre-initial verb position. Verbs in cleft constructions bear a high tone on the last syllable.

- (290) a. *E-le elya etabo i-ya-sha-a-som-w-á.*  
 7SM-COP 7DEM.dist 7book FOC-7REL-NEG-N.PST-read-PASS-FV  
 “It is that book that has not been read”
- b. *A-le wake mmɔlɔ i-o-ba-a-himb-á.*  
 1SM-COP 3SG.POSS 1brother FOC-1REL-2SM-N.PST-beat-FV  
 “It is his/her brother who they have beaten.”

Cleft sentences are marked in the sense that the semantic content of the proposition expressed by a cleft construction can be equally expressed by an unmarked simple clause. Thus, the propositional meaning expressed in (291a), can also be expressed via (291b).

- (291) a. *Ba-le baana i-ba-a-kol-á bilewa.*  
 2SM-COP 2child FOC-2REL-N.PST-buy-FV 8food  
 “It is the children who have bought food.”
- b. *Baana ba-a-kol-a bilewa.*  
 2child 2SM-N.PST-buy-FV 8food  
 “The children have bought food.”

Any type of argument can be clefted, subjects (292) as well as objects (293), locative DPs (295), adverbials (296) and other obliques (297). The same contrast in co-

occurrence restrictions that holds between subject DPs and subject markers in relative clauses hold in cleft constructions. Subject clefts show a preverbal subject DP with simultaneous relative marking on the matrix verb, as shown in (292).

- (292) a. *A-le Paul i-wa-a-hib-á bokyó.*  
 1SM-COP 1Paul FOC-1REL-N.PST-steal-FV 14money  
 “It is Paul who has stolen the money.”
- b. *E-le misea i-ya-a-shi-na-ly-á.*  
 4SM-COP 4girl FOC-4REL-N.PST-NEG-yet-eat-FV  
 “It is the girls who have not eaten.”
- c. *E-le ngyoʔa i-ya-yak-ilé anyoni.*  
 9SM-COP 9snake FOC-9REL-kill-PST 12bird  
 “It is the snake that killed the bird.”
- d. *Le-sh-ile hibwe i-lya-olo-ilé i-huma o-numba.*  
 5SM-COP-PST 5stone FOC-5REL-fall-PST from 16LOC-house  
 “It was a stone that fell from (on) the house.”

In object clefts, in turn, either subject marking but no overt subject DP appears (293b), or an overt subject DP but no subject marking (293c) is present. In analogy to object relative clauses, I will refer to these different types of cleft sentences as Type 1 and Type 2 object clefts, respectively.

- (293) a. *Bile bilewa i-bi-ba-koch-ilé.* [Type 1 object cleft]  
 8SM-COP 8food FOC-8REL-2SM-buy-PST  
 “It is food that they bought.”
- b. *Bile bilewa i-bya-koch-ilé baana.* [Type 2 object cleft]  
 8SM-COP 8food FOC-8REL-buy-PST 2child  
 “It is food that (some) children bought.”

The examples in (296) exemplify the use of clefts with extended and/or negated verbs.

- (294) a. *Bi-b-ile*      *bilewa*    *i-bi-na-lo-kol-el-á*                      *baana / ébo.*  
 8SM-COP-PST    8food      FOC-8REL-1SG-PST-buy-APPL-FV    2child    2it  
 “It was food that I bought for the children/them.”
- b. *Lo-b-ile*      *lolo*              *loho*    *i-lo-na-sha-koch-ilé.*  
 11SM-COP-PST    11DEM.med    11skin    FOC-11REL-1SG-NEG-buy-PST  
 “It was that skin that I did not buy.”
- c. *Lo-b-ile*      *lolo*              *loho*    *i-lwa-sha-kol-il-w-é.*  
 11SM-COP-PST    11DEM.med    11skin    FOC-11REL-NEG-buy-PST-PASS-FV  
 “It was that skin that has not been bought.”

The same co-occurrence restrictions hold in the case of clefting locative DPs. Subjects can either appear as DPs in postverbal position, or as subject marker on the verb, however, never simultaneously.

- (295) a. *Mu-le*      *m-lobonga*      *i-m-ba-kemb-ilé.*  
 18SM-COP    18LOC-11church    FOC-18REL-2SM-sing-PST  
 “It was in the church that they sang.”
- b. *Mu-le*      *m-lobonga*      *i-mwa-kemb-ilé*      *baana.*  
 18SM-COP    18LOC-11church    FOC-18REL-sing-PST    2child  
 “It was in the church that the children sang.”
- c. \**Mu-le*      *m-lobonga*      *i-m-ba-kemb-ilé*                      *baana*  
 18SM-COP    18LOC-11church    FOC-18REL-2SM-sing-PST    2child  
 (Int. “It was in the church that they sang.”)

(296) - (297) illustrate that time adverbials, and other obliques, such as the complements of prepositional phrases, can be clefted, too.

- (296) a. *E-b-ile*      *elya*              *ekolo*    *i-lo-na-mon-iné.*<sup>21</sup>  
 7SM-COP-PST    7DEM.dist    7night    FOC-11REL-1SG-see-PST  
 “It was yesterday that I met him.”

21 My language consultants contend that the class 11 object marker *lo-* is used instead of the instead of class 7 object marker *e-* because the more important reference is that of ‘day’ rather than ‘night’. Thus the class 11 object marker *lo-*, which cross-references the class 11 noun *lusuku* ‘day’, is used. However, I do not rule out that it could be due to some phonological process which prohibits a sequence of the two phonemes [i] and [e]. More data is needed to determine this.

b. *Lo-le lono lusuku i-lo-ni-shi-m-mon-é.*  
 1SM-COP 1DEM.dist 1day FOC-1REL-1SG-S.FUT-1OM-see-FV  
 “It is today that I will see him.”

(297) a. *E-b-ile poso i-e-twa-bokoch-ilé na eyo mchango.*  
 9SM-COP-PST 9axe FOC-9REL-1PL-open-PST with 9it 3door  
 (Lit. “It was the axe which we opened with it the door.”)  
 “It was the axe with which we opened the door.”

b. *O-b-ile mwele i-ho-na-bemb-ilé na eho nyama.*  
 3SM-COP-PST 3knife FOC-3REL-1SG-cut-PST with 3it 9meat  
 “It was the knife with which I cut the meat.”

Note that the sentence-initial copular verb can be inflected for other tenses, too.

(298) a. *Ba-le baana i-ba-mon-iné nyama.*  
 2SM-COP 2child FOC-2REL-see-FV 10animal  
 “It is the children who saw (some) animals.”

b. *Ba-b-ile baana i-ba-mon-iné nyama.*  
 2SM-COP-PST 2child FOC-2REL-see-FV 10animal  
 “It were the children who saw (some) animals.”

From an information-structural perspective, cleft constructions are primarily employed to express contrastive focus throughout the languages of the world, although there exist cases of languages that use cleft constructions in order to encode of informational focus (Lambrecht 2001). That Bembe uses cleft constructions for the expression of contrastive focus, too, is shown in (299).

(299) Q: *A-le beni i-wa-lech-ilé, John ao Maria?*  
 1SM-COP 1who FOC-1REL-cry-PST 1John or 1Mary  
 “Who cried, John or Mary?”

A: *A-le John i-wa-lech-ilé.*  
 1SM-COP 1John FOC-1REL-cry-PST  
 “It was John who cried.”

Since the question in (299a) restricts the choice of answers to a set of alternatives out of all possible alternatives, the answer will be inevitably contrastively focused. Thus, the grammaticality of a cleft construction (299c) as answer to (299a), supported by the ungrammaticality of (299b), confirms that cleft constructions in Bembe may have a contrastive nature, too.

If Bembe were able to encode information focus in cleft constructions, we should not be able to construct cleft constructions in which universal quantifiers (every, all etc.) or pronouns (e.g. everybody) occupy a position corresponding to that of the clefted element. The argumentation behind this is that clefted universal quantifiers imply a notion of totality that contradicts the contrastive nature of clefts. Consider the examples in (300) in this regard.

- (300) a. *Ba-b-ile      baana   bose   i-ba-lech-ilé.*  
           2SM-COP-PST 2child 2all FOC-2REL-cry-PST  
           ‘‘It was every child that cried.’’
- b. *Ba-b-ile      basolokoto   bose   i-ba-lo-watelech-á      *batu*.*  
           2SM-COP-PST 2soldier 2all FOC-2REL-PST-help-FV 2person  
           ‘‘It was all soldiers that helped people.’’
- c. *Ba-b-ile      batu   bose   i-ba-lo-watelech-á      *i-kuba-a*      *lobonga*.*  
           2SM-COP-PST 2person 2all FOC-2REL-PST-help-FV 5SM-build-FV 1church  
           ‘‘It was everybody that helped building a church.’’

As the examples in (300) show, universally quantified subjects can be clefted in Bembe. This suggests to some extent that cleft constructions in Bembe are used to express contrastive as well as information focus, at least in the case of clefted subjects. However, it should be stressed that, in fact, in those cases in which clefts are used to place information focus on an element, this is done with subjects of transitive verbs. It is likely that this is due to the restriction of focused transitive subjects to not appear in-situ in Bembe, i.e. in a preverbal position. However, given that Wh-object and adjunct questions can be answered in-situ and that the data necessary to determine whether objects and adjunct-clefts are also possible as answers to Wh-questions is not available, I cannot comment on the ability of object and adjunct-clefts to encode information focus. More data is needed to determine in how far cleft constructions in Bembe can encode not only contrastive but also information focus, and more importantly, whether

there exist restrictions on the elements that can be informationally focused via the use of clefts.

#### 2.4.4 Conditional clauses

There exist two ways of forming a conditional clause in Bembe: either with the lexical complementiser *nge* ‘if’ or with the bound potential marker *na-*. The former usually connects two clauses but can also appear in sentence-initial position. The latter is affixed to the verb in a position between subject marker and verbal root (see section 2.2.13). The following examples illustrate the usage of both the lexical *nge* (301) and the bound morpheme *na-* (302).

(301) a. *Mleka u-na-b-ile wangene nge Iddi a-na-ho-te-ile*  
 3beans 3SM-POT-COP-PST 3goodness if 1Iddi 1SM-POT-3OM-cook-PST  
 “The beans would have been good if Iddi had cooked them.”

b. *Nge Iddi a-na-te-ile mleka u-na-b-ile wa*  
 If 1Iddi 1SM-POT-cook-PST 3beans 3SM-POT-COP-PST 3CONN  
*ngene.*  
 3goodness  
 “If Iddi had cooked the beans, they would have been good.”

(302) a. *Iddi a-na-te-ile mleka, u-na-b-ile wa*  
 1Iddi 1SM-POT-cook-PST 3beans 3SM-POT-COP-PST 3CONN  
*ngene.*  
 3goodness

“If Iddi had cooked the beans, they would have been good.”

b. *Baana ba-na-l-ile, ta-ba-na-lwach-ile.*  
 2child 2SM-POT-eat-PST NEG-2SM-POT-be.sick-PST

“If the children had eaten, they would not have been sick.”



### 2.4.5 Interrogative clauses

#### *Affirmative polar interrogatives*

In Bembe, declarative sentences can be turned into polar questions by changing the intonation (i.e. pitch) to a rising one.

- (303) a. *Wa-a-lal-a?*  
2SG-N.PST-sleep-FV  
(Lit. "You have slept?")  
"Have you slept?"
- b. *Ba-a-w-a o-ly-a ale?*  
2SM-N.PST-finish-FV 15SM-eat-FV already  
(Lit. "They have finished eating already?")  
"Have they finished eating already?"
- c. *Wa-a-lal-a bya ngene?*  
2SG-N.PST-sleep-FV 8CONN goodness  
(Lit. "You have slept of goodness?")  
"Have you slept well?"

#### *Negative polar interrogatives*

- (304) a. *Ta-wa-a-lal-a bya ngene?*  
NEG-2SG-N.PST-sleep-FV 8CONN goodness  
"Have you not slept well?"
- b. *Ta-ba-a-hol-a?*  
NEG-2SM-N.PST-arrive-FV  
"Have they not arrived?"

#### *Tag questions*

Tag questions are possible in Bembe, however they are not frequently used. In order to form one, the verb is repeated at the end of the sentence, either in its affirmative or negated form, depending on the verb form in the matrix question.

- (305) *Wa-a-m-sangan-a, ta-wa-a-m-sangan-a?*  
 2SG-N.PST-1OM-meet-FV NEG-2SG-N.PST-1OM-meet-FV  
 (Lit. “You have met him, you haven’t met him?”)  
 “You have met him, haven’t you?”

*Non-polar interrogatives*

While I have presented the most frequent interrogative pronouns in section 2.2.12, this sub-section is intended to present the sentential word order facts of Wh-questions and discuss each interrogative pronoun in more detail. Generally speaking, in Bembe there exists a constraint on having focused or rather non-topical elements in preverbal position. Since Wh-phrases are inherently non-topical, as they are non-referential, this restriction naturally extends to Wh-phrases. The only element that is allowed to appear in preverbal position is the Wh-phrase *lumbaka lwa éé* ‘why’. While the rest of the Wh-words discussed in the following sub-sections can either be placed in postverbal position or in a Wh-cleft, questioned subjects of transitive verbs cannot ever appear pre- or postverbally but must always appear in a cleft construction.

*Beni*

The Wh-question word to ask for subjects in Bembe is *beni* ‘who’. It is disallowed from appearing in preverbal position, as in (306a) & (306c), but must instead be placed in a postverbal position, as in (306b) & (306d). Notice that agreement in intransitive subject Wh-questions is not with the postverbal Wh-subject but always with an expletive marker.

- (306) a. \**Beni a-a-chw-a?* [subject Wh-question]  
 1who 1SM-N.PST-come-FV  
 (Int. “Who has come?”)
- b. *ɔwa-a-chw-a beni?*  
 15EXPL-N.PST-come-FV 1who  
 (Lit. “Has come who?”)  
 “Who has come?”

- c. \**Beni wane mmɔɔ a-a-yak-a?* [object Wh-question]  
 1who 3SG.POSS 1brother 1SM-N.PST-kill-FV  
 (Lit. “Who my brother has killed?”)  
 (Int. “My brother has killed who?”)
- d. *Wane bamɔɔ ba-a-yak-a beni?*  
 3SG.POSS 2brother 2SM-N.PST-kill-FV 1who  
 “My brothers have killed who?”

Alternatively, Wh-questions can appear in the form of a cleft construction, as exemplified in (307). In Wh-clefts, the question word *beni* follows the inflected copula, and the verb is additionally marked with the prefix *i-* in verb-initial position.

- (307) a. *A-le beni i-wa-a-chw-á?* [Subject Wh-cleft]  
 1SM-COP 1who FOC-1REL-N.PST-come-FV  
 (Lit. “It is who that has come?”)  
 “Who has come?”
- b. *A-le beni i-wa-a-yak-á wane mmɔɔ?*  
 1SM-COP 1who FOC-1REL-N.PST-kill-FV3 SG.POSS 1brother  
 (Lit. “It is who that my brother has killed?”)  
 “My brother has killed whom?” [Object Wh-cleft]

With transitive verbs, there is an asymmetry between Wh-subject and Wh-object questions. While it is possible to place *beni* in postverbal position (306d) or in a cleft construction (307b) when asking for the object, matters are different in the case of subjects of transitive verbs. In order to ask for it, the Wh-question word *beni* is always disallowed from appearing in pre- or postverbal position (308a-b) but must instead appear in a cleft construction, as in (308c).<sup>22</sup>

- (308) a. \**Beni a-a-yak-a mboka?*  
 1who 1SM-N.PST-kill-FV 1neighbour  
 (Int.: “Who has killed a neighbour?”)

<sup>22</sup> There is of course the possibility of answering a subject question with a fragment answer consisting only of the focused element (e.g. “*Who was it?*” - “*Mary.*”). I will however not discuss this possibility.

- b. \*ʔwa -a-yak-a mboka beni?  
 1SM-N.PST-kill-FV 1neighbour 1who  
 (Int. “Who has killed a neighbour?”)
- c. A-le beni i-wa-a-yak-a mboka? [subject Wh-cleft]  
 1SM-COP 1who FOC-1REL-N.PST-kill-FV 1neighbour  
 (Lit.: “It is who who has killed a neighbour?”)  
 “Who killed a neighbour?”

As far as the information-structural content of Wh-questions is concerned, postposing *beni* in questions with intransitive verbs is used to ask for new information – i.e. one referent from the given set of all possible referents, while intransitive Wh-clefts ask for contrastive information – i.e. one referent from a restricted set of possibilities. Since pre- and postposing the Wh-question word *beni* with transitive verbs when asking for the subject results in an ungrammatical question, transitive subject Wh-clefts are used to ask for new and contrastive focus alike (309b).

- (309) a. Q: A-le beni i-wa-a-kol-á bilewa? [Subject Wh-cleft]  
 1SM-COP who FOC-1REL-N.PST-buy-FV 8food  
 (Lit. “It is who that has bought food?”)  
 “WHO has bought food?” / “It is WHO that has bought food?”
- b. A: A-le Iddi i-wa-a-kol-á bilewa. [Subject cleft]  
 1SM-COP 1Iddi FOC-1REL-N.PST-buy-FV 8food.  
 (Lit. “It is IDDI who has bought (some) food”)  
 “IDDI has bought food.” / “It is IDDI that has bought food.”

The differences in distribution of *beni* in Wh-subject and Wh-object questions with either intransitive and transitive verbs are summarised in Table 30.

Wh-question	Preverbal	Postverbal	Cleft construction
Subject (intrans.)	–	+	+
Subject (trans)	–	-	+
Object	–	+	+

Table 30: SUMMARY OF PLACEMENT FACTS FOR *beni* ‘who’

The placement facts of focused elements in answers to Wh-questions are identical to those described for the Wh-question word *beni* in Table 30. Answers to intransitive and transitive Wh-subject and object questions never show the focused element in preverbal position. Answers to intransitive Wh-subject questions must either place the Wh-question word in postverbal position (310a) or in a cleft construction (310b).

(310) Q: *ɔwa-a-chw-a* *beni?*  
 15EXPL-N.PST-come-FV 1who  
 (Lit. “Has come who?”)  
 “Who has come?”

A: a. *ɔwa-a-chw-a* *baana.*  
 15EXPL-N.PST-come-FV 2child  
 (Lit. “Have come the children.”)  
 “THE CHILDREN have come.”

b. *Ba-le* *baana* *i-ba-a-chw-á.*  
 2SM-COP 2child FOC-2REL-N.PST-buy-FV  
 (Lit. “It is THE CHILDREN that have come.”)  
 “It is THE CHILDREN that have come.”

Answers to transitive Wh-subject questions cannot show the focused element in pre- or postverbal position but must use the clefted form.

(311) Q: *A-le* *beni* *i-wa-a-kol-á* *bilewa?*  
 1SM-COP 1who FOC-1REL-N.PST-buy-FV 8food  
 (Lit. “It is who that has bought food?”)  
 “WHO has bought food?”

A: a. \**ɔwa-a-kol-á* (*Iddi*) *bilewa* (*Iddi*).  
 15EXPL-N.PST-buy-FV 1Iddi 8food 1Iddi

b. *A-le* *Iddi* *i-wa-a-kol-á* *bilewa.*  
 1SM-COP 1Iddi FOC-1REL-N.PST-buy-FV 8food.  
 (Lit. “It is IDDI who has bought (some) food”)  
 “It is IDDI that has bought food.”

In turn, answers to transitive Wh-object questions can either be placed in postverbal position (312a) or appear in the form of a cleft (312b).

(312) Q: *A-le* *beni* *i-wa-a-komb-á* *Maria?*  
 1SM-COP 1who FOC-1REL-N.PST-hit-FV 1Mary  
 (Lit. “It is who that Mary hit?”)  
 “Whom has Maria hit?”

A: a. *Maria* *a-a-komb-a* *Petelo*.  
 1Maria 1SM-N.PST-hit-FV 1Peter  
 “Mary has hit Peter”

b. *A-le* *Petelo* *i-wa-a-komb-á* *Maria*.  
 1SM-COP 1Peter FOC-1REL-N.PST-hit-FV 1Maria.  
 (Lit. “It is PETER who Maria has hit.”)  
 “Maria has hit Peter.”

Despite the distributional differences of *beni*, notice that an answer to a Wh-subject or object question need not be necessarily in the same form of the Wh-subject or object question to be felicitous. That is, a Wh-cleft can be answered either with a cleft construction or by positioning the new information in postverbal position, and vice-versa (always under the condition that the answer *can* take both forms, i.e. cleft or place *beni* postverbally, thus in answers to intransitive Wh-subject questions and transitive Wh-object questions).

*Éé* ‘what’

Besides *beni*, an alternative Wh-question word for arguments in Bembe is *éé* ‘what’. It shows the same distribution as *beni*, as illustrated in the examples in (313). Subjects of intransitive verbs cannot be questioned in preverbal position (313a) but only in situ, i.e. in post-verbal position (313b), or in a cleft construction (313c).

(313) a. \**Éé* *ea-a-yak-a* *batu?* [*\*preverbal*]  
 7what 7SM-N.PST-kill-FV 2man  
 (Int. “What has killed the people?”)

- b. *ɔwa-a-kwel-a*      *éé?*      [postverbal]  
 15EXPL-N.PST-fall-FV 7what  
 (Lit. “Has fallen (down) what?”)  
 “What has fallen down?”
- c. *E-le*      *éé*      *i-ea-a-kwel-a?*      [cleft construction]  
 7SM-COP 7what FOC-7REL-N.PST-fall-FV  
 (Lit. “It is what that has fallen (down)?”)  
 “What has fallen (down)?”

Subjects of transitive verbs cannot be questioned in pre- or postverbal verbal position (314a-b) but, instead, are always placed in cleft construction (314c).

- (314) a. *\*Ea-a-yak-a*      (*éé*)      *batu*      (*éé*)?      [\*postverbal]  
 7SM-N.PST-kill-FV 7what 2man 7what  
 (Int. “What has killed the people?”)
- b. *\*Éé*      *ea-a-yak-a*      *batu?*      [\*preverbal]  
 7what 7SM-N.PST-kill-FV 2man  
 (Int. “What has killed the people?”)
- c. *E-le*      *éé*      *i-ea-a-yak-a*      *batu?*      [cleft construction]  
 7SM-COP 7what FOC-7REL-N.PST-kill-FV 2person  
 “It is what that has killed the people?”

Objects are questioned in situ, i.e. in post-verbal position (315b), or in a cleft construction (315c) but never in preverbal position (315a).

- (315) a. *\*Éé*      *ea-a-yak-a*      *batu?*      [\*preverbal]  
 7what 7SM-N.PST-kill-FV 2man  
 (Int. “What has killed the people?”)
- b. *Batu*      *ba-a-kol-a*      *éé?*      [postverbal]  
 2person 2SM-N.PST-buy-FV 7what  
 (Lit. “The people have bought what?”)  
 “What have the people bought?”

- c. *E-le* *éé* *i-ea-a-ly-a* *Iddi?* [cleft construction]  
 7SM-COP 7what FOC-7REL-N.PST-eat-FV 1Iddi  
 “It is what that Iddi has eaten?”

The differences in distribution of *éé* in Wh-subject and Wh-object questions with intransitive and transitive verbs are summarised in Table 31.

	Preverbal	Postverbal	Cleft construction
Subject (intrans.)	–	+	+
Subject (trans.)	–	–	+
Object	–	+	+

Table 31: SUMMARY OF PLACEMENT FACTS FOR *éé* ‘what’

*olé/olehé* ‘where’

In order to ask for a location in Bembe, the Wh-question word *ole* (or alternatively *olehé*) is used. *Ole(hé)* is always placed in situ with copular and intransitive verbs, i.e. at the end of the sentence, and in a clefted position whenever the verb used is transitive.

- (316) a. *O-le* *olé(hé)?*  
 2SG-COP 17where  
 (Lit. “You are where?”)  
 “Where are you?”
- b. *A-le* *olé(hé)* *i-ha-ba-a-ly-á* *mleka?*  
 16SM-COP 17where FOC-16REL-2SM-N.PST-eat-FV 3beans  
 “It is where that they have eaten beans?”

If it is assumed that the location is close to the speaker, either of the two Wh-question words *hale* or *halehé* is used. The question words *alé(hé)* and *olé(hé)* seem to derive from the class-16 and class-17 locative markers *a-* and *o-*, respectively.



- (317) *E-le hale(hé)?*  
 7SM-COP 16where  
 (Lit. “It is where?”)  
 “Where is it?”  
 (e.g. when looking for a particular sheet of papers on a table full of sheets of paper)

*bile(hé)* ‘how’

The question words for ‘how’ in Bembe are *bile* or *bilehé*. The examples (318a-c) illustrate that *bile/bilehé* can appear in postverbal position or be clefted. It cannot appear in preverbal position (318d). Note that in the case of a cleft construction, the copular verb and the accompanying focus marker on the matrix verb cannot be omitted.

- (318) a. *Na-a-sol-a makye bile/bilehé?*  
 1SG-PRES-drink-FV 6water 8how?  
 “How do I drink the water?”
- b. *O-na-tend-a bibio bile/bilehé?*  
 2PL-POT-say-FV 8DEM.prox 8how  
 (Lit. “You can say that how?”)  
 “How can you say that?”
- c. *Bi-le bile(hé) i-bi-o-na-tend-a bibio?*  
 8SM-COP 8how FOC-8REL-2PL-POT-say-FV 8DEM.prox  
 (Lit. “It is how that you say that?”)  
 “How can you say that?”
- d. \**Bile(hé) na-a-sol-a makye?*  
 8how 1SG-PRES-drink-FV 6water  
 (Int. “How do I drink the water?”)

*lumbaka lwa éé* ‘why’

The Wh-question phrase *lumbaka lwa éé* ‘why’ (lit. ‘because of what’) can be placed at sentence-final or at sentence-initial position, and can also be clefted.

- (319) a. *Wa-a-chw-a      lumbaka   lwa      éé?*  
 2SG-N.PST-come-FV 11because 11 CONN 7what?  
 (Lit. “Because of what have you come?”)  
 “Why have you come?”
- b. *Lumbaka   lwa      éé      *wa-a-chw-a?**  
 11because 11CONN 7what 2SG-N.PST-come-FV?  
 (Lit. “Because of what have you come?”)  
 “Why have you come?”
- c. *Lo-le      lumbaka   lwa      éé      *i-lwa-a-atom-a**  
 11SM-COP 11because 11CONN 7what FOC-11SM-N.PST-make-FV  
*wa-a-chw-a?*  
 2SG-N.PST-come-FV  
 (Lit. “It is because of what that has made you come?”)  
 “What made you come?”

It is the only Wh-element that can also appear in sentence-initial position with transitive verbs, as illustrated in (320).

- (320) *lumbaka   lwa      éé      *ba-koch-ile*   *kyenge?**  
 11because 11CONN 7what 2SM-buy-PST 9fufu  
 “Why did they buy fufu?”

CONN+*beni* ‘whose’

There is no dedicated Wh-question word in order to ask for the possessor of something, i.e. ‘whose’. Instead, the periphrastic connective construction in conjunction with the question word *beni* is employed, as shown in (321).

- (321) a. *Bitabo   bya      beni      *bya-hib-il-w-e?**  
 8book 8CONN 1who 8SM-steal-PST-PASS-PST  
 (Lit. “books of who were stolen?”)  
 “Whose books were stolen?”

- b. *kyenge ya tama ya beni*  
 9fufu 9CONN blandness 9CONN 1who  
 (Lit. “fufu of bland of who”)  
 “whose bland fufu”

*Lolé(hé)/mango beni* ‘when’

Bembe offers two different ways of asking for the point in time in which an action has taken place. *Lolé* or *lolehé* ‘when’ is used generally when no assumptions about the point in time of the action are made by the speaker. However, when the speaker thinks that it is likely that the action is, will be or has been undertaken on the same day the question is uttered, the Wh-question phrase *mango beni* ‘what time’ is used.

- (322) a. *Ba-chu-le lolé(hé)?*  
 2SM-come-PST 11when  
 “When did they come?” (vague: days etc)
- b. *Ba-a-chw-a mango beni?*  
 2SM-N.PST-come-FV 6time 1who  
 (Lit. “They have come at time who?”)  
 “When did they come?” (more precise/specific: on the same day)

*Lolé(hé)* as well as *mango beni* can appear in sentence-final (in-situ) position, as illustrated in (322a-b), and in cleft construction (323a-b) but never in preverbal position (323c).

- (323) a. *Male mango beni i-ma-ba-chu-le?*  
 6SM-COP 6time 1who FOC-6REL-2SM-come-PST  
 “When did they come?”
- b. *Lole lolé(hé) i-lo-ba-chu-le.*  
 11SM-COP 11when FOC-11REL-2SM-come-PST  
 (Lit. “It is when that they came?”)  
 “When did they come?”
- c. *\*Lolé(hé)/mango beni lo/ma-ba-chu-le.*  
 11when 6time 1who 11/6REL-2SM-come-PST  
 (Int. “When/at what time did they come?”)

NP + *beni* ‘which’

Bembe does not feature a question word that is exclusively used to ask for one or more alternatives of a set of given alternatives, such as English ‘which’. Instead, the question word *beni* in conjunction with a DP is used.

- (324) a. *Bi-le*     *bilewa* *beni*    *i-bi-o-shi-kol-e?*  
8SM-COP 8food 1who FOC-8REL-2SG.OM-S.FUT-buy-FV  
(Lit. “It is food what that you will buy?”)  
“Which food will you buy (then)?”
- b. *Bi-le*     *bito*    *beni*    *i-bi-o-shi-tend-e?*  
8SM-COP 8thing 1who FOC-8REL-2SG.OM-S.FUT-buy-FV  
(Lit. “It is things what that you will say?”)  
“Which things will you say (then)?”

The sentential distribution is identical to that of the Wh-question word *beni*. It can always appear in a Wh-cleft construction. When asking for a subject, it can appear postverbally with intransitives but never in preverbal position. When asking for transitive subjects, it has to appear in a cleft. When asking for an object, it can only appear postverbally or in a Wh-cleft but never in preverbal position.

*-nga* ‘how many’

Bembe makes a distinction when asking for the specific quantity of a certain noun. When the noun in question is a count noun, *-nga* ‘how many’ is simply prefixed with the corresponding class marker. Note that *bokye* ‘money’ counts as a count noun in Bembe; hence *bokyo bonga* in the example in (325b) is interpreted as ‘how many’ despite its English gloss ‘how much money’. However, *-nga* cannot simply be combined with mass nouns to ask for a quantity. Instead, speakers must resort to some unit of measurement used for the mass noun in question. It is the noun used as unit of measurement that determines the agreement on the verb. This is exemplified with the nominal *makye* ‘water’ in (325c-d).

- (325) a. *Ba-le batu banga i-ba-chu-le?*  
 2SM-COP 2person 2how.many FOC-2REL-come-PST  
 (Lit. “It is people how many that came?”)  
 “How many people came?”
- b. *Bo-le bokyo bongga i-bo-ba-o-h-ile?*  
 14SM-COP 14money 14how.many FOC-14REL-2SM-2SG.OM-give-PST  
 (Lit. “It is money how many that they gave you?”)  
 “How much money did they give you?”
- c. \**Ma-le makye mange i-ma-o-shi-sol-e?*  
 6sm-cop 6water 6how.many FOC-6REL-2PL-S.FUT-drink-FV  
 (Lit. “It is water how many that you will drink?”)  
 (Int. “How much water will you drink (then)?”)
- d. *To-le tochuba twa makye tonge*  
 13SM-COP 13bowl 13CONN 6water 13how.many  
*i-to-o-shi-sol-e?*  
 FOC-13REL-2SG-FUT-drink-FV  
 (Lit. “It is water bowls of water how many that you will drink?”)  
 “How much water will you drink (then)?”

The Bembe Wh-question words discussed in this section and their sentential distribution are summarised in Table 32.

Wh-word		Position in the clause			
		Pre-verbal	Post-verbal	Cleft construction	
<i>beni</i> ‘who’	Subject	(trans.)	-	-	+
		(intrans.)	-	+	+
<i>ée</i> ‘what’	Object	-	+	+	
<i>ole(hé)</i> ‘where’		-	+	+	
<i>bile(hé)</i> ‘how’		-	+	+	
<i>lumbaka lwa éé</i> ‘why’		+	+	+	
<i>lole(hé)/manga beni</i> ‘when’		-	+	+	
NP + <i>beni</i> ‘which’		-	+	+	

-nga ‘how many’	-	+	+
-----------------	---	---	---

Table 32: BEMBE WH-WORDS AND THEIR SENTENTIAL DISTRIBUTION

*Multiple questions*

Bembe restricts the clause-initial position to be occupied by only one Wh-word, and only in the form of a cleft-construction.

- (326) *A-le    beni    i-wa-tend-ile    éé    ole beni    lole    na ole?*  
 1SM-COP 1who FOC-1REL-say-PST 7what to 1who 11when and where  
 “Who said what to whom when and where?”

Bembe shows superiority effects in multiple Wh-questions. The standard definition of superiority states that, in a multiple Wh-question, the Wh-question word that experiences fronting is the structurally highest one (cf. Vicente 2013). That is, a low Wh-question word cannot skip over a higher one. Thus, (327a) in Bembe is a well-formed multiple question while (327b) is not.

- (327) a. *A-le    beni    i-wa-som-ile    éé?*  
 1SM-COP 1who FOC-1REL-read-PST 7what  
 “It is who that read what?”
- b. \**E-le    éé    i-ea-som-ile    beni?*  
 7SM-COP 7what FOC-7REL-read-PST 1who  
 (Lit. “It is what that read who?”)  
 (Int. “It is who that read what?”)

## CHAPTER 3 - OBJECT MARKING IN BEMBE

### 3.1 Introduction

#### 3.1.1 General properties of Bantu object marking

Object marking is the Bantu-typical process of cross-referencing object arguments through inflectional morphemes on the verb. There exists variation across Bantu languages with regard to their position on the verb, the number of possible co-occurring object markers, and their distribution. In their typological study of object marking in Bantu, Beaudoin-Lietz et al. (2004) propose a three-way distinction of Bantu languages with regard to the position of the object marker. In Type 1 languages object markers precede the verb stem, in Type 2 languages they are placed in verb-final position, while in Type 3 languages they can appear in both positions. Consider (328).

- (328) a. *U-li-ni-ona.* (Swahili)  
2SM-PST-1OM-see  
“You saw me.”
- b. *Go á si bee me.* (Konzime; Beaudoin-Lietz et al. 2004: 183)  
you PAST2 PFV see me  
“You saw me.”
- c. *N-a-mw-ink-á-wu.* (Lunda; Beaudoin-Lietz et al. 2004: 184)  
1SM- PAST2- 1OM-give-FV-3OM  
“I gave him it.”

As regards the number of possible object markers, most Bantu languages allow at least one, while some allow multiple markers. Descriptively speaking, among those languages that allow multiple markers, the majority limits the co-occurrence to two or three object markers, although there do exist languages that allow a higher number, such as Kinyarwanda, which allows up to six (Marten & Kula 2007; Marten, Kula & Thwala 2007; Marlo 2013). Consider (329).

- (329) a. *Njûchi zi-na-wa-lum-a.* (Chicheŵa; B&M 1987: ex.1)  
10bees 10SM-PAST-2OM-bite-FV  
“The bees bit them.”

- b. *Ya-wu-mú-haa-ye.* (Ha; Harjula 2004: 133)  
 SM1.REM-3OM-1OM-give-PERF  
 “She gave it to him.”
- c. *Umugoré a- ra- na- ha- ki- zi- ba- ku- n-*  
 1woman SM1- FOC- ALSO- 16OM- 7OM- 10OM- 2OM- 2OMS- 1OMS  
*someesheeshereza.*  
 read.CAUS.CAUS.APPL.APPL  
 “The woman is also making us read it (book) with them (glasses) to you for  
 me there (in the house).” (Kinyarwanda, Beaudoin-Lietz et al. 2004:183)

From a syntactic point of view, the most interesting aspect of object marking in Bantu is certainly the distributional variation one encounters and the constraints that govern it. While most Bantu languages allow object marking, most notably in the case of non-overt lexical objects (Lingala being the notable exception), it is in no case obligatory for all lexical objects. In some Bantu languages object marking only occurs with certain types of objects, while with all other objects it is optional. Obligatory object marking, for example, is the case in Chaga (Marten et al. 2007), Swahili and Sambia (Baker 2008; Riedel 2009). It is also obligatory for Makhuwa (Van der Wal 2009) but only in the case of human referents, i.e. nouns of the classes 1/2 and proper names. Yet in other languages, like Nyaturu (Rimi) (Hualde 1989) or Ruwund (Nash 1992), object marking is restricted to specific and definite animate objects, respectively, but prohibited with any other objects. Consider (330), which shows that, in Swahili, object marking with human objects is obligatory while it is optional with other animate objects, such as animals. Note that in Swahili, marking animate objects, also in case they denote animals, always induces class 1/2 marking on the verb.

- (330) a. *Ni-li-\*(mw)-ona Juma.* (Swahili; Riedel 2009: 42)  
 1SM-PST-1OM-see 1Juma  
 “I saw Juma.”
- b. *Ni-li-(mw)-ona mbwa.*  
 1SM- PST-1OM-see 9dog  
 “I saw the/a dog.”



In contrast, although Haya allows object marking of any lexical objects, it is always optional, i.e. there is no semantically or syntactically defined class of objects that requires obligatory object marking. This is illustrated in (331).

- (331) a. *N-ka-ki-(mu)-h-a*                      *Kristina.*                      (Haya; Riedel 2009: 53)  
           1SM-PAST3-7OM-1OM-give-FV    *Kristina*  
           ‘‘I gave it to Kristina.’’
- b. *A-ka-(m)-bon-a*                      *inye.*  
           1SM-PAST3-1OM-see-FV    *me*  
           ‘‘S/he saw me.’’

In some instances, the term ‘doubling’ is used to refer to the process of object-marking a co-referential lexical object, and is sometimes accompanied by the terms ‘local’ and ‘non-local’. The latter terms are employed if one wants to indicate that doubling, or object marking<sup>23</sup>, can only occur if the lexical object and the object marker are in a local relationship, i.e. in the same syntactic domain, or in different ones. This distinction becomes important when considering Bantu languages like Chicheŵa, which as opposed to Swahili or Haya, disallow any instance of local doubling but permit non-local doubling of lexical objects. That is, Chicheŵa allows doubling of lexical objects only if the latter is in a dislocated position, such as in topicalisation or afterthought-constructions, as indicated in (332) by the gloss and the comma.

- (332) a. *Njŭchi*    *zi-ná-lúm-a*                      *alenje.*                      (Chicheŵa; B&M 1987: 744)  
           10bees    10SM-PST-bite-FV    2hunters  
           ‘‘The bees bit the hunters.’’
- b. *Njŭchi*    *zi-ná-wa-lum-a,*                      *alenje.*  
           10bees    10SM-PST-2OM-bite-FV    2hunters  
           ‘‘The bees bit them, the hunters (that is).’’

---

23 Throughout this thesis, the expression ‘object-marked object’ is used interchangeably along that of ‘doubled object’ for cases in which the verb bears an object-marker co-referential with the (optionally omitted) object NP.

### 3.1.2 Overview of the chapter

Naturally, the amount of variation in object marking illustrated in the preceding section has sparked different theoretical analyses of the phenomenon, and there exists a long-standing debate that centers on the question as to whether object markers should be analysed as agreement or pronominal morphemes. In the literature on Bantu object marking, it is commonly assumed that if object markers can double an object locally, they should be analysed as grammatical agreement morphemes. If, in turn, they cannot double an object locally, i.e. when they are in complementary distribution with lexical objects with regard to the inflectional domain, they should be analysed as being pronominal. Thus, while some languages have been analysed as having grammatical object agreement, such as Makhuwa (van der Wal 2009), Chaga (Marten et al. 2007), Swahili and Smbaa (see Baker 2008; Riedel 2009 and references therein), others have been claimed to feature pronominal object markers, most famously Haya (Baker 2008; Bearth 2003; Byarushengo et al. 1976; Duranti and Byarushengo 1977), Chicheŵa (B&M 1987; Lethsolo 2002; Mchombo 2004), Northern Sotho (Demuth 1990; Zerbian 2006), and Zulu (van der Spuy 1993; Zeller 2012). If the object marker were the argument of the verb, it is expected that lexical objects appear in a dislocated position. Cross-linguistically, dislocated elements receive a definite or topical reading (see Cinque 1990; Rizzi 1986, 1997; and Baker 2003 among others for Bantu). Since it has been claimed that object-marked objects in many Bantu languages do indeed exclusively receive such an interpretation (cf. Ashton 1944; Doke 1931; Nash 1992), they are traditionally analysed as dislocated topics in a range of Bantu languages (cf. Byarushengo et al. 1976; Tenenbaum 1977; van der Spuy 1993).

Riedel (2009) points out that most diagnostics in the literature are not helpful in determining the status of object markers since they yield contradictory results and are unable to account for the range of variation within the Bantu language family, which leads her to dismiss the agreement/pronoun dichotomy altogether. Instead, she claims that a general analysis of Bantu object marking as grammatical-agreement phenomenon is to be preferred, also for those Bantu languages in which object marking is seemingly pronominal. She argues that once a language shows one instance of local doubling, it should be analysed as being an agreement language, and accordingly develops a grammatical-agreement analysis of Smbaa, Chicheŵa and Haya, languages that have traditionally been analysed as having pronominal object markers rather than agreement markers.

Taking B&M's seminal (1987) work about subject and object marking in Chicheŵa as a starting point, in section 3.2, I will present and discuss the evidence that has been brought forward in favour of analysing object markers as being pronominal in languages such as Chicheŵa, Haya, and Zulu. While I do acknowledge the higher amount of explanatory power Riedel's (2009) agreement analysis of the Bantu language Haya offers over alternative pronominal approaches, I object to her claim that an agreement analysis should be extended to all instances of Bantu object marking. As I will argue in section 3.3, applying the traditional diagnostics to Bembe yields clear evidence that object-marked objects are in fact dislocated, which strongly suggests that object marking is hence pronominal. In contrast, Riedel's (2009) and alternative grammatical-agreement approaches seem to be unable to explain the Bembe data.

While I agree with Riedel (2009) to the extent that the dichotomy is *de facto* incapable of accounting for the variation in Bantu object marking, this does not mean that it should be abandoned in favour of either an agreement or pronominal analysis. Rather, the dichotomy should be exchanged for a more flexible view of object marking, according to which Bantu languages are situated on some point on a spectrum or continuum that is demarcated at one extreme by languages with strict pronominal object-marking, e.g. Bembe, and at the other by languages with strict grammatical object-marking, e.g. Swahili and Makhuwa. In-between those extremes are those languages that show characteristics of pronominal as well as grammatical object marking, such as Chicheŵa, Haya or Zulu, which may simply be the manifestation of change in progress from a pronominal-based object-marking system to a grammatical agreement one. This is in line with suggestions made by Bresnan (2001), Creissels (2001), Givón (1976, 1979), Siewierska (1999) and Zeller (2012) amongst others.<sup>24</sup>

Having established Bembe object marking as being a pronominal phenomenon, the aim of section 3.4 is to determine precisely what kind of pronouns object markers are. On the basis of distributional and interpretational evidence, I conclude that they are

---

24 Givón (1976) has shown that grammatical agreement systems originate diachronically in anaphoric relations between incorporated pronouns and their antecedents. The transition from one stage into the next can be shown by forms that exhibit characteristics of both systems, i.e. synchronic variation is linguistic change in progress. In the same vein, Zeller (2012: 18) raises the question whether the "mixed properties" shown by some Bantu languages like Chicheŵa, Haya and Zulu may "reflect intermediate stages of a grammaticalisation process that turns pronominal object markers into agreement morphemes", and assumes that most of the languages in question "lie somewhere between the two opposite ends of the agreement-pronoun continuum." Given that those Bantu languages in question show characteristics of both pronominal and grammatical object marking to a varying degree across syntactic constructions, I believe that it is in fact more advantageous to speak of a spectrum or continuum rather than of determinate stages on which to position these languages.

best analysed as defective clitic pronouns, more specifically as  $\phi$ Ps (following Cardinaletti & Starke 1999).

The aim of section 3.5 is to determine the structural representation of Bembe object markers. I discuss a number of proposals (Sportiche 1992/1996, 1998; Julien 2002; B&M 1987) that have been advanced in the literature as to how to structurally account for clitic-placement facts. These proposals are either unable or in too much need of modification to account for the Bembe object-marking patterns. Instead, I follow Roberts (2010a,b) and claim that object markers are base-generated in argument position as featurally-defective clitics (i.e.  $\phi$ Ps) and subsequently incorporate into  $v$  after the verb has moved from V to  $v$ . Such an analysis is comparable to the one Roberts proposes for cliticisation in Romance languages. From him I adopt the idea that the prerequisite for the incorporation of a head into another head is nothing else than the operation *Agree* that takes place between a probe and a potential goal, in the course of which the defective structure of  $\phi$ Ps allows for their incorporation into other heads. For Bembe, in particular, this means that subject markers are attracted by and incorporate into T (as we shall see in Chapter 4), while object marker/clitics do so with  $v$ . The fact that incorporation of defective pronouns into  $v$  can be equally well explained by assuming that it is triggered by the need to value a feature suggests that despite all differences that exist between affixes and clitics, pronominal and grammatical agreement are actually two sides of the same coin (cf. Givón 1976, Roberts 2010a,b).

The chapter closes with a summary of the main findings and conclusions in section 3.6.

## **3.2 Agreement markers vs. incorporated pronoun**

### **3.2.1 Diagnostics to distinguish agreement from incorporation**

B&M (1987) describe the asymmetries between (obligatory) subject and (optional) object agreement in Chicheŵa, and provide a Lexical-Functional-Grammar (LFG) analysis to account for them. They differentiate between *grammatical agreement*, in which case the subject/object marker is analysed as a redundant affix expressing the noun-class of a co-referenced lexical subject/object, and *anaphoric agreement*, where the subject/object marker is an incorporated pronoun with full argument status. According to B&M, a number of asymmetries between lexical subjects and lexical objects in Chicheŵa are accounted for under an analysis that treats subject markers as ambiguous between grammatical and anaphoric agreement, and object marking as being

anaphoric agreement. In case the object marker doubles the object, B&M argue that the doubling is only apparent and that, in fact, the lexical object actually occupies a right-dislocated position outside the *vP*, as is the case in the example in (334) (indicated by the comma in the gloss).

(333) a. *Njûchi zi-ná-wa-lúm-a alenje.*  
 10bees 10SM-PST-2OM-bite-FV 2hunter  
 “The bees bit the hunters.”

b. *Njûchi zi-ná-wa-lúm-a.*  
 10bees 10SM-PST-2OM-bite-FV  
 “The bees bit them.”

(334) [<sub>TP</sub> *Njûchi* [<sub>AspP</sub> *zi-ná-wa-lúm-a* [<sub>VP</sub> [<sub>VP</sub> ]]]], [*alenje* ]  
 10bees 10SM-PST-2OM-bite-FV 2hunter  
 “The bees bit them, the hunters.” (Chichewa; B&M 1987: 744)

In order to corroborate their claim that object-marked lexical objects are obligatorily dislocated, B&M present evidence from word order, phonology, prosody, co-occurrence restrictions with in-situ Wh-phrases and relative clauses. One central piece of evidence is the fact that the use of object markers increases the word-order possibilities. Consider the examples in (335); from B&M 1987: 744-745), which show that out of six logical word-order permutations, only two are grammatical in Chichewa.

(335) a. *Njûchi zi-ná-lúm-a alenje.* S V O  
 10bees 10SM-PAST-bite-FV 2hunters  
 “The bees bit the hunters.”  
 b. *Zi-na-lum-a alenje njûchi.* V O S  
 c. *\*Alenje zi-na-lum-a njûchi.* O V S  
 d. *\*Zi-na-lum-a njûchi alenje.* V S O  
 e. *\*Njûchi alenje zi-na-lum-a.* S O V  
 f. *\*Alenje njûchi zi-ná-lúm-a.* O S V

However, with the insertion of an object marker, all six become instantly grammatical:

- (336) a. *Njûchi zi-ná-wá-lúm-a alenje.* S V O  
 b. *Zi-na-wá-lum-a alenje njûchi.* V O S  
 c. *Alenje zi-na-wá-lum-a njûchi.* O V S  
 d. *Zi-na-wá-lum-a njûchi alenje.* V S O  
 e. *Njûchi alenje zi-na-wá-lum-a.* S O V  
 f. *Alenje njûchi zi-ná-wá-lúm-a.* O S V

B&M point out that this is expected under an approach that sees object markers as pronominal arguments, since the formerly ungrammatical word orders (335c-f) are licensed by the insertion of an object marker and the necessarily dislocated position of lexical objects. However, it is worth pointing out that Sambia and Haya, two languages that *do* allow local clitic-doubling and are analysed as having grammatical object agreement by Riedel (2009), show the same word-order freedom. This weakens the word-order argument considerably, as it is unexpected under B&M's analysis.

A further piece of evidence comes from the fact that verbs undergo changes in tonal marking and lengthening of the penultimate syllable whenever they appear in the final position of the verb phrase. B&M notice that transitive verbs that are followed by a lexical object usually bear a high tone on the last syllable. However, whenever no overt lexical object is present, for example because of the subcategorisation requirements of the verb, the high tone on the last syllable of the verb retracts to a high or rising tone on the penultimate syllable, which in addition undergoes vowel lengthening (the latter phenomenon is not indicated in their original data). B&M claim that this happens systematically to signal the boundary of the verb phrase. Consider the contrast in tone in (337a-b).

- (337) a. *Ndi-ku-fún-á kutí áná ánga [ a-pítirizé phúnziro].*  
 1SM-PRES-want-FV that 2child 2my 2SM-continue.SUBJ 5lesson  
 "I want my children to continue the lesson."  
 b. *Ndi-ku-fún-á kutí áná ánga [ a-sêke]*  
 1SM-PRES-want-FV that 2child 2my 2SM-laugh.SUBJ  
 "I want my children to laugh." (Chicheŵa; B&M 1987: 750)

Thus, when the object-marked verb experiences tonal retraction and penultimate lengthening despite being followed by a lexical object, for B&M this is proof that said object must be outside of the verb phrase, since the tonal change signals the boundary of

a phrase. In (338), the last syllable of the object-marked verb is missing the usual high tone, and instead shows a rising tone in addition to vowel lengthening on the penultimate syllable. B&M take these facts as evidence for the claim that object markers must be argumental in Chicheŵa.

- (338) *Ndi-ku-fún-á kutí áná ánga [a-li-pítíri:ze] phúnziro.*  
 1SM-PRES-want-FV that 2child 2my 2SM-5OM-continue.SUBJ 5lesson  
 “I want my children to continue it, the lesson.” (Chicheŵa, B&M 1987: 750)

As a further argument for the pronominal status of object markers, B&M present co-occurrence restrictions between object markers and Wh-phrases. In the presence of an object marker, an agreeing noun phrase cannot be questioned in situ. B&M argue that this is predicted since Wh-phrases are inherently non-topical, as they are non-referential, and hence cannot co-occur with object markers, which indicate a topic status of the co-referring lexical object. An element cannot be topic and non-topical at the same time, since these concepts are incompatible, which would cause the derivation to crash. Instead, either the object marker is omitted, as in (339a-b), or a question in the form of a cleft is used, as in (339c). In the latter construction, the Wh-phrase and the topical object marker are claimed to be in two different clauses, thereby escaping an otherwise incurred theta-criterion violation.

- (339) a. (*Kodí*) *mu-ku-fún-á chiyâni?* (Chicheŵa; B&M 1987: 759-760)  
 Q you-PRES-want-FV 7what  
 “What do you want?”
- b. (*Kodí*) *mu-ku-(\*chi)-fún-á chiyâni?*  
 Q you-PRES-7OM-want-FV 7what  
 “What do you want?”
- c. *Kodí ndí chiyâni chi-méné mú-kú-chi-fún-a?*  
 Q COP 7what 7-REL 2SG-PRES-7OM-want-FV  
 “What is it that you want?”

A further argument comes from the availability of object markers in object relative clauses. As opposed to Wh-phrases, which are non-topical, the relative pronoun usually fulfills a topical function, and is thus merged in a dislocated position. It is

therefore predicted that the verb needs to satisfy its subcategorisation requirement (i.e. theta-role in Generative terminology) by inserting an object marker that is cross-referenced with the relative pronoun in topic position. B&M show that this prediction is borne out for Chicheŵa. Consider the examples in (340) in this respect.

- (340) a. *Njovu ziméné anyani a-ku-zĩ-pats-a mikánda*  
 10elephants 10REL 2baboons 2SM-PST-10OM-give-FV 4beads  
*zĩ-ma-dy-á nzímbe.*  
 10SM-HAB-eat-FV 10sugar cane  
 ‘‘The elephants that the baboons are giving beads to eat sugar cane.’’
- b. ??*Njovu ziméné anyani a-ku-pats-a mikánda*  
 10elephants 10REL 2baboons 2SM-PST-give-FV 4beads  
*zĩ-ma-dy-á nzímbe.*  
 10SM-HAB-eat-FV 10sugar.cane  
 ‘‘The elephants that the baboons are giving beads to eat sugar cane.’’
- (Chicheŵa; Mchombo 2004: 41)

One further diagnostic proposed in the literature that I would like to mention, although not applicable to Chicheŵa, is the obligatory use of disjoint verb forms when object doubling occurs. In Zulu, which display the conjoint/disjoint alternation, a conjoint verb form cannot appear in final position but only before a focused element. If the verb is to appear in final position, the disjoint form of that verb has to be employed, which is argued to delimit the verb phrase (Buell 2005, 2006). (However, note that this diagnostic is problematic with respect to double object constructions from which an object has been extracted, as the conjoint form has to be employed obligatorily; see Buell 2005: 64; also Halpert 2013). If object marking were pronominal and therefore dislocation of the object-marked object necessary, two predictions follow: first, a transitive verb should not be able to appear in its disjoint form without being object-marked, and secondly, a conjoint verb-form should not be able to be object-marked and appear with a local lexical object. The fact that the phrase-boundary delimiting disjoint verb-form is used in conjunction with object markers in Zulu is thus taken as evidence by van der Spuy (1993) for the claim that the lexical object is not in the vP but rather dislocated, and the object marker hence pronominal. Consider the data in (341).



- (341) a. *Ba-thanda*                      *ibhola*.    (Zulu; van der Spuy 1993: 340)  
           2SM-like.PRES.CJ      football  
           ‘‘They like football.’’
- b. *Ba-ya-li-thanda*                      (*ibhola*).  
           2SM-PRES.DJ-OM-like      football  
           ‘‘They like football.’’

Based on the presented diagnostics, with exception of the one based on disjoint/conjoint alternations of the verb since it does not apply to Chicheŵa, B&M conclude that object marking in Chicheŵa cannot be grammatical but instead must be anaphoric agreement. However, there exist problems with their analysis including some of their underlying assumptions, which I will discuss in the following section.

### 3.2.2 Discussion

The claim that the insertion of an object marker increases the sentential word-order possibilities, as we have seen earlier, gives contradictory results when applied to other Bantu languages. As mentioned, Sambia and Haya, two languages that allow local clitic-doubling and should thus lend themselves to a grammatical object-agreement analysis, also show the same word-order freedom when inserting an object marker. This is unexpected in B&M’s theory and weakens the word-order argument noticeably. Given the contradictory results it yields across languages, I thus dismiss this diagnostic as not useful.

In addition, it is important to point out that B&M’s analysis is situated within a Lexical Functional Grammar (LFG) framework, which differs from other generative approaches to syntax in that it does not assume movement operations to take place. Naturally, the predictions LFG theories makes are, in part radically, different to the predictions made by a transformational theory. One environment in which this becomes visible is that of object relative clauses, and in particular with respect to the presence or absence of object marking. Given that an operation such as *Move  $\alpha$*  is non-existent in LFG, there exists no alternative other than to merge relativised objects directly into a dislocated position. What follows from this is that if the relativised object does not start out in the *vP/VP*, it will not be accessible to theta-role distribution by *v*. This then predicts that pronoun resumption in the inflectional domain is always based on the sub-categorisation requirements of the verb, and thus expected in case of transitive and



always in an adjunct position, and thus demarcates the vP boundary. If an object-marked object were able to precede the adverb, this would constitute robust evidence against the pronominal status of object markers since lexical object and object marker would occupy positions within the same inflectional domain. As a consequence, this would lead the derivation to crash, as both elements would compete for the same position and theta-role. Hence it is expected that object-marked objects follow adverbials if object markers are pronominal agreement markers, whereas they should be able to precede adverbials if they are grammatical agreement markers. Consider the examples in (343) in this respect.

(343) a. *Ndi-na-funa kuti mu-wa-pats-é mphatso dzulo, alenje.*  
 1SM-PST-want that 2SG-2OM-give-SUBJ 3gift yesterday 2hunter  
 “I wanted you to give them a gift yesterday, the hunters.”

b. *Ndi-na-funa kuti mu-wa-pats-é mphatso alenje dzulo.*  
 1SM-PST-want that 2SG-2OM-give-SUBJ 3gift 2hunter yesterday  
 “I wanted you to give the hunters a gift yesterday.”

(Chicheŵa, Henderson 2006b: 171, translation modified)

In Chicheŵa, the syntactic status of object-marked objects as being dislocated is supported primarily by the presence of an intonation break, which precedes the object-marked object if the latter appears after a temporal adverb, as indicated by the comma in the gloss of (343a) (Henderson 2006b: 171). However, there is no such intonation break in the example presented by Henderson in (343b), in which the object-marked object precedes the temporal adverb. This is unexpected if the object marker were pronominal. Hence Henderson concludes, contra B&M, that the lexical object *alenje* ‘hunter’ in (343b) is not dislocated, and thus that the object marker cannot be an incorporated (argument) pronoun but rather must be a grammatical agreement marker.

Finally, Riedel shows that the diagnostics used to show right-dislocation of object-marked objects also produce inconsistent results with regard to Haya, another Bantu language that has traditionally been analysed as having pronominal object marking (cf. Duranti and Byarushengo 1977; Tenenbaum 1977). I will limit myself to illustrating two of her counter-examples, one from the order of object-marked object and temporal adverbs and one from the order of object-marked and non object-marked objects in double object constructions. First, consider the example in (344).

- (344) a. *Y-a-(\*mu)-bona*                      *Kato kileki.*                      (Haya; Riedel 2009: 71)  
           1SM-PAST1.CJ-1OM-see    1Kato today  
           “He saw Kato today.”
- b. *Y-aa-mu-bona*                      *Kato kileki.*  
           1SM-PAST1.DJ-1OM-see    1Kato today  
           “He saw Kato today.”

Tenenbaum (1977) claims for Haya that, when a lexical object precedes a temporal adverb, as shown in (344a), object marking is ungrammatical. In contrast, (344b), which comes from Riedel’s data, illustrates how object marking with the same word order is in fact grammatical. This is unexpected under a pronominal analysis of object markers and casts doubt on Tenenbaum’s claim that object-marked objects in Haya must be dislocated.

Similarly, it is claimed that an object-marked object cannot precede a non-object-marked object in Haya, as shown in (345a) (the comma indicates an intonation break). However, Riedel again juxtaposes personal data from Haya (345b), which shows that constructions in which the object-marked indirect object precedes the non object-marked direct object are in fact productive and grammatical. Consider the contrast between Tenenbaum and Riedel’s data in (345a-b).

- (345) a. *\*Ba-ka-mu-cumbila,*                      *Kakulu enkoko.*                      (Haya; Tenenbaum  
           2SM-PAST3-1OM-cook.APPL    1Kakulu 9chicken                      1977: 163)  
           (Int. “They cooked it for Kakulu the chicken.”)
- b. *Ba-ka-mu-cumbila*                      *Kakulu enkoko.*                      (Haya; Riedel  
           2SM-PAST3-1OM-cook.APPL    1Kakulu 9chicken                      2009: 72)  
           “‘They cooked the chicken for Kakulu.’”

In summary, we have seen that the presence of (a) object markers in object relative clauses, (b) the free order between object-marked and non-object-marked objects, and (c) the free order of object-marked objects and temporal adverbs in double-object constructions, each suggesting a grammatical-agreement approach to object marking, stand in sharp contrast to the pronominal evidence stemming from the tonal marking of phrase boundaries and the ban on object-marked Wh-phrases brought forward by B&M. These facts lead Henderson (2006b) to ultimately analyse Chicheŵa

as having grammatical object agreement, and Riedel (2009) to extend such an analysis to the languages Sambia and Haya.

I do acknowledge the discussed inconsistencies and agree with the conclusion that Chichewa and Haya can be equally well analysed as having grammatical object agreement, especially in the light of the contradictory results some of the diagnostics yield. However, I object to Riedel's more general conclusion that the agreement-pronoun dichotomy is incapable of accounting for the variation encountered across Bantu and should thus be abandoned in favour of a general grammatical-agreement analysis of object marking for all Bantu languages. Riedel argues that if there is one grammatical instance of local doubling in a Bantu language, then object marking should be analysed as an instance of grammatical agreement. I believe that her conclusion is flawed because to the same extent that a pronominal-agreement analysis is unable to account for cases of local doubling of lexical objects, a grammatical-agreement analysis is unable to account for the tonal retraction and vowel lengthening facts and the impossibility of object-marking Wh-phrases in Chicheŵa. Therefore, while I agree with Riedel to the extent that the dichotomy is de facto incapable of accounting for the variation in Bantu object marking, this does not mean that it should be abandoned in favour of either an agreement or pronominal analysis. Rather, the dichotomy should be solved in favour of a more flexible view of object marking, according to which Bantu languages are situated on some point on a spectrum that is demarcated at one extreme by languages with strict pronominal object-marking, e.g. Bembe, and at the other by languages with strict grammatical object-marking, e.g. Makhuwa. In-between those extremes are those languages that show properties of both phenomena, such as Chicheŵa, Haya or Zulu, which I assume to be in the process of converting from pronominal to grammatical agreement, i.e. undergoing change in progress, in line with suggestions made by Bresnan (2001), Creissels (2001), Givón (1976, 1979), Siewierska (1999) and Zeller (2012) (see also footnote 24).

### **3.3 A pronominal analysis of Bembe object markers**

#### **3.3.1 General properties**

Beaudoin-Lietz et al. (2004) discuss the variation in object marking across Bantu from a morpho-syntactic point of view, and present a tripartite distinction of Bantu languages based on the linear position of object markers. Type 1 languages, which are predominant in the Bantu language continuum, show one or more object markers, which

always precede the verb stem. Type 2 languages, in turn, show up to two object markers but differ in that they immediately follow the verb stem. Finally, Type 3 languages are characterised by pre- and post-stem insertion of object markers.

Object markers in Bembe are attached to the verb, in a position immediately preceding the verb stem and following the tense marker. Bembe is thus a Type 1 language.<sup>25</sup> A different form exists for every noun class with the exception of the three locative ones. As in other Bantu languages, object markers can replace lexical objects, as shown in the examples in (346b), but cannot double a local lexical object, as shown in (346c).<sup>26</sup>

- (346) a. *Mwana a-a-yak-a ngyo?a.*  
 1child 1SM-N.PST-kill-FV 9snake  
 “The child has killed a snake.”
- b. *Mwana a-a-ya-yak-a.*  
 1child 1SM-N.PST-9OM-kill-FV  
 “The snake has killed it.”
- c. *Mwana a-a-(\*ya)-yak-a ngyo?a.*  
 1child 1SM-N.PST-9OM-kill-FV 9snake  
 “The child has killed a snake.”

Bembe allows object marking of direct (346), indirect (347), and applicative (348) arguments. In each case, the maximum number of co-occurring object-markers is limited to one. However, object marking of locatives is not possible, as shown in (349).

- (347) a. *Baana ba-h-ile Petelo bilewa.*  
 2child 2SM-give-PST 1Peter 8food  
 “The children gave Peter food.”
- b. *Baana ba-m-h-ile bilewa.*  
 2child 2SM-1OM-give-PST 8food  
 “The children gave him food.”

---

25 Note that the analyses and discussion presented in this thesis will be limited to pre-stem object markers since Bembe only displays pre-stem object markers.

26 Language examples that appear without language name are Bembe.

c. *Baana ba-bi-h-ile Petelo*  
 2child 2SM-8OM-give-PST 1Peter  
 “The children gave it to Peter.”

d. \**Baana ba-m-bi-h-ile.*  
 2child 2SM-1OM-8OM-give-PST  
 (Int. “The children gave it to him.”)

(348) a. *A-a-koch-el-a baana hembe.*  
 1SM-N.PST-buy-APP-FV 2child 10mango  
 “S/he has bought mangos for/on behalf of the children.”

b. *A-a-ba-koch-el-a hembe.*  
 1SM-N.PST-2OM-buy-APP-FV 10mango  
 “S/he has bought mangos for/on behalf of them.”

c. *A-a-chi-koch-el-a baana.*  
 1SM-N.PST-10OM-buy-APP-FV 2child  
 “S/he has bought them for/on behalf of the children.”

d. \**A-a-ba-chi-koch-el-a*  
 1SM-N.PST-2OM-10OM-buy-APP-FV  
 (Int. “S/he has bought them for/on behalf of them.”)

(349) a. *Baana ba-a-chw-a o-no.*  
 2child 2SM-N.PST-come-FV 17LOC-DEM.prox  
 “The children have come here.”

b. \**Baana ba-a-o-chw-a.*  
 2child 2SM-N.PST-17OM-come-FV  
 (Int. “The children have come here.”)

In the next section, I consider the question whether certain semantic features of objects such as definiteness and/or specificity play a role in object marking in Bembe, before applying the discussed diagnostics to the data.

### 3.3.2 Differential object marking

Before applying the discussed diagnostics to Bembe in order to determine whether object marking should be treated as pronominal or grammatical agreement-phenomenon, I will first clarify the question whether the semantic features animacy, humanness, definiteness or specificity, which have been linked to object marking in other Bantu languages, are decisive factors in Bembe too. If this were the case, it would suggest that object marking is a matter of grammatical agreement. Some languages like Swahili, for instance, object-mark only animate and specific objects (Riedel 2009), while others like Makhuwa-Enahara only object-mark objects belonging to the noun classes 1 or 2 (van der Wal 2009). Given that most Bantu languages lack determiners (except for those in which the augment can be demonstrated to take up this function), it is also often claimed that the presence of object markers expresses definiteness or specificity. In this section I determine whether object marking in Bembe is related to either of these semantic features, or whether the reason for object marking has to be found in other factors.

#### *Humanness, kinship & animacy*

In Bembe, all objects with human referents can but need not be necessarily object-marked. In fact, it is ungrammatical to object-mark object nouns with human referents, unless the lexical object is separated from the rest of the clause by an intonation break. This is evidenced by the contrast in (350). In (350b), object marking is not grammatical, whereas in (350c), in which the lexical object receives an afterthought reading, and (350d), where the lexical object is fronted to indicate a topic shift in the discourse, it is not only grammatical but obligatory.

- (350) a. *Na-mon-ine Iddi.*  
1SG-see-PST 1Iddi  
“I saw Iddi.”
- b. \**Na-m-mon-ine Iddi*  
1SG-1OM-see-PST 1Iddi  
(Int. “I saw Iddi.”)



- c. *Na-\*(m)-mon-ine \*(,) Iddi*  
 1SG-1OM-see-PST 1Iddi  
 “I saw him, Iddi (that is).”
- d. *Iddi, na-\*(m)-mon-ine*  
 1Iddi 1SG-1OM-see-PST  
 “Iddi, I saw him.”

Object-marking with kinship terms patterns in the same way, i.e. it is ungrammatical to object-mark kinship terms, unless the referent of that kinship term is separated from the rest of the clause by an intonation break, as shown in (351).

- (351) a. *Na-mon-ine tata.*  
 1SG-see-PST 1father  
 “I saw my father.”
- b. *\*Na-m-mon-ine tata.*  
 1SG-1OM-see-PST 1father  
 (Int. “I saw (my) father.”)
- c. *Na-\*(m)-mon-ine \*(,) tata.*  
 1SG-1OM-see-PST 1father  
 (Int. “I saw him, (my) father.”)
- d. *Tata \*(,) na-\*(m)-mon-ine.*  
 1father 1SG-1OM-see-PST  
 (Int. “(My) father, I saw him.”)

Object marking of personal pronouns patterns in the same way. Again, it is not obligatory to object-mark personal pronouns, nor is it grammatical unless the personal pronoun is separated by prosodic means from the rest of the clause. The examples in (352) illustrate this.

- (352) a. *Na-(\*m)-mon-ine εwe.*  
 1SG-1OM-see-PST him  
 “I saw him.” or “I saw HIM.”

- b. *Èwe, na-\*(m)-mon-ine.*  
 he 1SG-1OM-see-PST  
 ‘‘Him, I saw him.’’

Thus, while any semantic kind of object can be object-marked in Bembe, it is only obligatory in the cases (350c-d), (351c-d) and (352b). Given the definite readings object-marked objects receive in these examples, object marking could be conditioned by either specificity and/or definiteness. Whether this is the case will be determined in the next section.

### *Specificity*

Specificity is a further, oft-cited factor shown to be the decisive trigger for object marking in a range of Bantu languages. A noun phrase is said to be specific/referential when the speaker assumes the existence of a particular referent in the universe. Definite expressions referring to unique entities, such as *the sun*, are hence specific/referential, as they refer to existing entities. Indefinite expressions can also be specific, as shown in (353) (from Payne 1997: 265).

- (353) *Arlyne wanted to marry a Norwegian, but he refused.*

In (353), the speaker presupposes that a person from Norway exists that *Arlyne* wanted to marry but he does not identify this individual because he either does not assume that the hearer can identify him, or the identity of the referent is simply not important. The noun phrase *a Norwegian* is hence understood as specific yet indefinite (Givón 2001: 440; Hawkins 1978: 215).

A non-specific/non-referential expression connotes the type of an entity and is used in its attributive sense. The referent of the expression is taken to be a typical representative of its class (Givón 1978: 294, 2001: 440; Hawkins 1978: 209, 215; Werth 1980: 257). This is illustrated by the indefinite article *a* in the following example (354), in which the speaker does not assume the existence of a particular individual from Norway. *A Norwegian* in this case refers not to a particular individual in the set of Norwegian men, but rather to a hypothetical representative example of the whole set.

- (354) *Arlyne wanted to marry a Norwegian (any), but couldn't find one.*

It has for long been a matter of debate whether definite expressions can also be interpreted as being non-specific/non-referential. While some assume that definiteness entails specificity and therefore excludes definite non-specifics (Enç 1991; Gundel, Hedberg & Zacharski 1993: 278 n.2), others assume that definite expressions can indeed be either non-specific or specific (Givón 1978: 294; Hawkins 1978: 215; Payne 1997: 265). Following von Heusinger (2002: 10), I assume that specificity is a “referential property” of noun phrases. Just like the concept of genericity, it cuts across the distinction of definite vs. indefinite. Definite noun phrases thus need not be always specific. Consider the English example in (355; taken from von Heusinger 2002: 11), which unequivocally shows that definite expressions can have a non-specific meaning.

(355) *They’ll never find the man that will please them.*

A Bantu language that employs object-marking in order to mark specificity in animate objects is Ruwund (L53; Nash 1992). The examples in (356a-b) show that, with animate objects, object marking of objects and proper names results in a specific interpretation, while non-object-marking of objects induces a non-specific interpretation (356c).

- (356) a. *ku-mu-kimb muntu* (Ruwund; Nash 1992: 565)  
 INF-1OM-look.for 1person  
 “to look for a/the person”
- b. *ku-\*(mu)-tàl Yâav*  
 INF-1OM-visit 1 Yaav  
 “to visit Yaav”
- c. *ku-kimb muntu*  
 INF-look.for 1person  
 “to look for any person”

If Bembe employed object marking to express specificity, every specific expression should trigger object marking, while object marking of non-specific expressions should result in ungrammaticality. However, the first of the two predictions is not borne out since there do exist specific expressions that are not object-marked without resulting in ungrammaticality. Consider the example in (357) in which the

indefinite object *mtu* ‘man’ with the generic reading ‘someone’, is made specific by means of a relative clause, and results in ungrammaticality if object-marked.

- (357) *A-le mo-(\*m)-lond-a mtu w-ikyo-tend-á Bembe.*  
 1SM-COP PROG-1OM-search-FV 1man 1REL-HAB-speak-FV Bembe  
 “He is looking/searching for someone who speaks Bembe.”

With regard to the second prediction that a non-specific expression should not be able to co-occur with an object marker, consider the examples in (358).

- (358) a. *Ta-ba-shi-(\*m)-mon-e okyo mtu u-na-ba-ɔwatelech-a.*  
 NEG-2SM-S.FUT-1OM-see-FV 1DEM 1man 1REL-POT-2OM-help-FV  
 “They will not find (see) that person that could help them.”
- b. *Ta-ba-shi-\*(m)-mon-e, okyo mtu u-na-ba-ɔwatelech-a.*  
 NEG-2SM-S.FUT-1OM-see-FV 1DEM 1man 1REL-POT-2OM-help-FV  
 “They will never find (see) him, that person that could help them.”

The objects in (358a-b) are both definite and non-specific. While the sentence in (358a) seems to confirm the prediction that non-specific expressions should not trigger object marking, the example in (358b) shows that it is in fact necessary in case the lexical object is separated from the rest of the clause by means of an intonation break (indicated by the comma) and thus dislocated. Notice that the example in (358b) is constructed in such a way that the referent of the object *okyo mtu unaaɔwatelecha* is supposed to be known from the preceding discourse but remains non-specific for whatever reasons. Now, since dislocation of an object does not have any effect on its specificity, and the object is thus still definite and non-specific, the obligatory co-occurrence of an object marker and a definite, non-specific expression in (358b) contradicts the prediction made under an approach which treats object markers as specificity markers. I therefore conclude that object markers in Bembe cannot be markers of specificity.

### *Definiteness*

Another semantic feature driving object marking in many Bantu languages is the concept of definiteness. An expression is definite when a speaker presupposes that the hearer can identify the referent of the expression. Put differently, the speaker assumes the existence of a unique referent which is identifiable by the hearer, either because (a)

the referent is known from the discourse, (b) because the referent forms part of what is referred to as world knowledge, or (c) because the referent is sufficiently well-described (Givón 2001: 450; Gundel, Hedberg & Zacharski 1993: 277; Hawkins 1978: 167-168; Payne 1997: 263).

An example of a Bantu language that expresses definiteness qua object marking is Nyaturu (F32; Hualde 1989). When an animate object is object-marked, it is necessarily interpreted as definite; otherwise it will receive an indefinite interpretation. Consider the examples in (359) which show that personal pronouns and proper names expectedly make no exception to this.

- (359) a. *N-a-m̩-ona*      *mwalimu.*      (Nyaturu; Hualde 1989: 182)  
           1SG-PST1-1OM-see 1teacher  
           “I saw the teacher.”
- b. *N-a-ona*      *mwalimu.*  
           1SG-PST1-see 1teacher  
           “I saw a teacher.”
- c. *N-a-m̩-ona*      *Maria.*  
           1SG-PST1-1OM-see 1Maria  
           “I saw Maria.”
- d. \**N-a-ona*      *Maria.*  
           1SG-PST1-see 1Maria  
           (Int: “I saw Maria.”)
- e. *N-a-k̩-ona*      *(veve).*  
           1SG-PST1-2OM-see you  
           “I saw you.”
- f. \**N-a-ona*      *veve.*  
           1SG-PST1-see you  
           (Int.: “I saw you.”)

With regard to the predictions made under a view that treats object markers as markers of definiteness, these are easily tested. Firstly, all definite objects should trigger object marking, and, secondly, all object-marked objects should be definite. Consider the Bembe examples in (360) in this respect.

- (360) a. *Na-a-(\*chi)-ond-a chicho nyama.*  
 1SG-PRES-10OM-love-FV 10DEM 10animals  
 “I love those animals.”
- b. *A-(\*ho)-hib-ile wane mwele.*  
 1SM-3OM-steal-FV 1SG.POSS 3knife  
 “He stole my knife.”
- c. *Ba-(\*m)-yak-ile wane mlome.*  
 2SM-1OM-kill-PST 1SG.POSS 1husband  
 “They killed my husband.”

The examples show that the first prediction according to which all definite objects necessarily trigger object marking is not borne out, as objects modified by demonstratives or possessives, and thus definite objects, cannot co-occur with object markers.

As regards the second prediction, that all object-marked objects should be definite, consider the examples in (361), which show the main contexts in which object marking is found in Bembe, i.e. topicalisations and after-thought constructions.

- (361) a. *Chicho nyama \*(,) na-a-\*(chi)-ond-a.*  
 10DEM 10animals 1SG-PRES-10OM-love-FV  
 “Those animals, I love them”.
- b. *Na-a-\*(chi)-ond-a \*(,) chicho nyama.*  
 1SG-PRES-10OM-love-FV 10DEM 10animals  
 “I love them, those animals (that is).”
- c. *Wane mlome \*(,) ba-\*(m)-yak-ile.*  
 1my 1husband 2SM-1OM-kill-PST  
 “My husband, they killed him.”
- d. *Ba-\*(m)-yak-ile \*(,) wane mlome.*  
 2SM-1OM-kill-PST 1my 1husband  
 “They killed him, my husband (that is).”

In all of the above examples the object-marked objects are definite. However, in contrast to the objects in (360), they are obligatorily separated by an intonation break from the rest of the clause, suggesting that they are dislocated, which is supported by

their interpretation as discourse-old constituents. Thus, while the examples above show that definiteness must play some role in object marking, I conclude that it is not the only or decisive criterion for object marking. Rather only a subset of all definite objects allows object marking, namely discourse-old objects, i.e. topics. In this respect, consider the example in (362).

- (362) *A-wech-ile*    *Maria* *nibo ba-a-ond-a*    *i-m-ɔwatelech-a*.  
 1SM-tell-PAST    1Mary that    2SM-PRES-want-FV    5SM-1OM-help-FV  
 “He told Mary that they want to help her.”

The referent of the objects of both verbs in (362) is the same and definite, i.e. the proper name *Maria* in the matrix clause and the object marker in the subordinate clause refer to the same person named Maria. Despite the fact that proper names are typically considered definite, only the verb in the subordinate clause is object-marked. Since the definite object in the matrix clause is not object-marked, it can only mean that not definiteness but something else must be the decisive factor. The only other difference between the lexical object *Maria* and the object marker *m-* in (362) that has hitherto not been taken into account is the difference in information-structural status between the two. Both lexical object and object marker refer to the same referent (the person called *Maria*) but the difference is that the referent of the lexical object *Maria* is newly introduced into the discourse, while it counts as discourse-old once the object marker *m-* picks it up again. This confirms that topicality of the object is the real driving force behind object marking in Bembe, thus only a subset of all definite objects are object-marked and not just any definite ones.

It would be difficult to pursue a pronominal-agreement approach to object marking if we had found that only elements with certain semantic features are object-marked in Bembe. Such object-marking patterns would lend themselves better to a differential grammatical-agreement analysis (cf. Aissen 2003; Morimoto 2002; Dalrymple & Nikolaeva 2011). However, as this is not the case and, instead, only discourse-old elements are object-marked, this is highly suggestive of a pronominal nature of object marking. Further evidence for a pronominal-agreement approach to Bembe object marking comes from the application of the earlier-mentioned diagnostics, which will be discussed in detail in the next sub-section.

### 3.3.3 Evidence in favour of pronominal object-marking in Bembe

In this sub-section, I will apply the diagnostics that I have presented and discussed in section 3.2 to the Bembe data in order to determine whether object marking is a matter of grammatical or pronominal agreement. Only a subset of the diagnostics proposed in the Bantu literature can be applied with respect to Bembe. The distribution of conjoint/disjoint verb forms, for instance, cannot be exploited to determine phrase boundaries since they are absent in Bembe. With regard to the argument according to which object marking increases sentential word-order possibilities, the earlier-mentioned fact that Swahili also show an increase in sentential word-order possibilities in the presence of an object marker despite being traditionally analysed as having grammatical object-agreement leads me to dismiss it as not being useful, as it yields contradictory results (as shown by Riedel 2009). The remaining tests that will be applied to Bembe are based on phonological, interpretational and distributional evidence, which will in one form or the other show that lexical objects are obligatorily dislocated in the presence of an object marker, implying that the argumental status of object markers is responsible for the dislocation.

If object markers are treated as pronominal elements, including the ability to bear a theta-role, this naturally predicts co-occurrence restrictions between object markers and various other elements in a number of constructions, which can be easily tested. Concretely, under a pronominal approach to object marking it should be ungrammatical:

- (i) for object-marked objects to precede time adverbials in transitive clauses;
- (ii) for object-marked objects to precede time adverbials, Wh-phrases, and non-object-marked objects in ditransitive clauses; and
- (iii) to object-mark indefinite, focused, passivised, relativised and negative polarity items in either transitive or ditransitive contexts.

#### *Obligatory intonation break*

As opposed to conjoint/disjoint verb-forms, Bembe offers intonation breaks to indicate phrase boundaries, in a way comparable to other forms of phrase-boundary marking devices such as tonal retraction and/or vowel lengthening in Chicheŵa. The presence of object-marked objects makes the use of such an intonation break obligatory, which suggests that object-marked objects are in fact in a dislocated position, and thus topics. Consider the examples in (363) which illustrate that object marking is only allowed in



case a lexical object is omitted, as in (363b), or if it is occupying a left- or right-dislocated position, as in (363c-d).

- (363) a. *Mwana a-a-(\*ya)-yak-a ngyo?a.*  
 1child 1SM-N.PST-9OM-kill-FV 9snake  
 “The child has killed a/\*the snake.”
- b. *Mwana a-a-\*(ya)-yak-a.*  
 1child 1SM-N.PST-9OM-kill-FV  
 “The child has killed it.”
- c. *Mwana a-a-ya-yak-a \*(,) ngyo?a.*  
 1child 1SM-N.PST-9OM-kill-FV 9snake  
 “The child has killed it, the/\*a snake (that is).”
- d. *Ngyo?a \*(,) mwana a-a-ya-yak-a.*  
 9snake 1child 1SM-N.PST-9OM-kill-FV  
 “The snake, the/\*a child has killed it.”

*Interpretational difference*

Apart from the obligatory intonation break, the examples in (363) also illustrate how lexical objects that are interpreted as foci and/or indefinites cannot be doubled by an object marker on the verb. In constructions without overt lexical objects, as in (363b), the referent of the omitted object can only be interpreted as a definite, and, in particular, discourse-old one, and must hence be licensed by a corresponding object marker on the verb. Cases of lexical objects co-occurring with object marking, such as (363c-d) are only apparent cases of local doubling, as we have just seen that an obligatory intonation break between verb and lexical object (indicated by the comma) illustrates that they are in fact in a non-local relationship. In (363c) the lexical object receives an afterthought reading, and in (363d) it is used to signal a shift with respect to the topic of the discourse. Importantly, in the examples (363b-d), the lexical object cannot ever receive an indefinite or focused interpretation, which is evidenced by the fact that neither of the sentences in (363b-d) can be used as answer to an all-new Wh-question of the type “*What happened?*” or to one asking for the object. These facts are expected under a pronominal approach to object marking, yet not under a grammatical agreement approach.

*Ban on object-marking Wh-phrases*

Another prediction that a pronominal approach makes is that Wh-phrases asking for the object should naturally be ungrammatical in conjunction with object marking. The underlying assumption is that Wh-phrases are inherently non-topical, as they are non-referential, which should make them incompatible with object marking, since we have just established that the latter is a topic phenomenon, which forces marked objects into a dislocated position. Consider the examples in (364) in this respect.

- (364) a. *Iddi a-a>(\*he/m)-yak-a éé / beni?*  
1Iddi 1SM-N.PST-7/1OM-kill-FV 7what / 1who  
(Lit. “Iddi has killed what/who?”)  
“What/who has Iddi killed?”
- b. *Iddi a-a(\*he)-kol-a éé?*  
1Iddi 1SM-N.PST-7OM-buy-FV 7what  
(Lit. “Iddi has bought what?”)  
“What has Iddi bought?”

The examples illustrate that the prediction made by a pronominal approach is borne out. An object Wh-phrase cannot appear with simultaneous object marking since the inherent non-referentiality of Wh-phrases is incompatible with the topic interpretation associated with dislocation. Under an agreement approach, in contrast, the examples are predicted to be grammatical, since nothing should impede the verb to agree with an object Wh-phrase, contrary to facts.

Note that the question whether Wh-phrases can be object-marked is particularly interesting in the light of proposals that posit that agreement between any elements in Bantu always involves a null element *pro* (cf. Baker 2003, 2008; Riedel 2009) in order to account for the topic interpretation subjects and objects alike often show in Bantu. One theory-internal consequence is that agreement with Wh-phrases, too, should always be via a null element *pro*, while Wh-phrases should be merged in a dislocated position. The prediction is the same as with other agreement analyses, as we thus expect an object-marker to show up in (364), which however is contrary to facts. What is more, it is inconceivable to assume that Wh-phrases, which are inherently non-referential, would always be in a dislocated position in the light of the fact that, from a cross-linguistic perspective, dislocated elements receive a topic interpretation.

*Ban on object-marking negative polarity items*

Further evidence comes from negative polarity items and their inability to be object-marked. This follows from an account in which negative polarity items must occupy a VP-internal position, i.e. an A-position, since they are interpreted as indefinite non-specifics (Diesing 1992). Object marking is presumably excluded on the grounds that it would incur a theta-criterion violation, as two elements, the object marker and the negative polarity item, would compete for the same position, and thus the same theta-role. Consider the examples in (365).

- (365) a. *Shi-na-a-(\*m)-mon-a mtu.*  
NEG-1SG-N.PST-1OM-see-FV 1man  
“I have not seen anybody.”
- b. *Shi-na-a-(\*m)-mon-ak-a mtu u-shi-ikyo-chimb-a.*  
NEG-1SG-N.PST-see-DUR-FV 1man 1REL-NEG-HAB-lie-FV  
“I have never seen any man who does not lie.”

*No object-marking in object relative clauses*

Another argument in favour of treating object markers as pronominal elements comes from their complementary distribution with lexical objects in object relative clauses. This is correctly predicted under a pronominal approach, as it is assumed that the object moves out of the embedded clause into some dislocated position in the left periphery. Since it is base-generated within the embedded clause, there is no position left which the object marker could possibly occupy. Under an agreement approach, in contrast, nothing predicts object marking in (366) to be ungrammatical.

- (366) *Ngvo?a ya-a>(\*ya)-yak-a mwana ya-b-ile ya mmilu.*  
9snake 9REL-N.PST-9OM-kill-FV 1child 9SM-COP-PST 9CONN blackness  
“The snake which the child has killed was black.”

*No object marking with passives*

Another domain in which the ungrammaticality of object marking is predicted is passivisation. If object passive-structures are derived by promoting the object to subject status, as is standardly assumed, it follows that objects cannot be object-marked since they would otherwise compete with the object marker for the same position. Put differently, although passivised objects have the status of topics, as they must typically

be interpreted as discourse-old and as such cannot surface in the inflectional domain at the end of the derivation, it is their vP-internal origin that prohibits simultaneous object marking. Consider (367).

- (367) a. *Ngvo?a ya-a>(\*ya)-yak-w-a na mwana.*  
 9snake 9SM-N.PST-9OM-kill-PASS-FV by 1child  
 “The snake has been killed by a child.”
- b. *Bilewa bi-a>(\*bi)-kol-w-a na Iddi.*  
 8food 8SM-N.PST-8OM-buy-PASS-FV by 1Iddi  
 “The food has been bought by Iddi.”

*\*Object-marked objects > adverbials*

Moreover, the canonical word order between lexical objects and adverbials of time is such that the adverbial always follows any objects in the clause (368a). This is expected since it is generally assumed that adverbials are external. In the presence of object marking, however, objects must not precede time adverbials (368b) but must follow them (368c). The object-marked object is additionally separated by an intonation break. This is predicted under a pronominal analysis in which object-marked objects are taken to occupy a dislocated position, however, not under a grammatical agreement analysis.

- (368) a. *Ba-koch-ile bilewa elya ekolo.*  
 2SM-buy-PST 8food 9DEM.dist 9night  
 “They bought food yesterday.”
- b. *Ba>(\*bi)-koch-ile bilewa elya ekolo*  
 2SM-8OM-buy-PST 8food 9DEM.dist 9night
- c. *Ba-\*(bi)-koch-ile elya ekolo \*(,) bilewa.*  
 2SM-8OM-buy-PST 9DEM.dist 9night 8food  
 “They bought it yesterday, the food (that is).”

*Double-object constructions*

Further evidence that object marking in Bembe is pronominal comes from double-object constructions, i.e. ditransitive as well as applicative constructions. Firstly, the co-occurrence restrictions identified so far between object marking and indefinite, focused,

relativised, passivised elements and negative polarity items are also visible in double-object constructions. In the examples in (369), the ungrammaticality of object marking is expected since the argumental character of the object marker is either incompatible with the indefinite, non-referential/focal properties of the objects (369a-b), or restricted from co-occurring in order to not incur a theta-violation (369c-d).

- (369) a. *Iddi a-a>(\*he)-kol-el-a baana éé?* [\*Wh-phrase]  
 1Iddi 1SM-N.PST-7OM-buy-APPL-FV 2child 7what  
 “Iddi has bought the children what?”
- b. *Ta-ba-a(\*bi)-kol-el-a baana bilewa.* [\*Neg. pol.]  
 NEG-2SM-N.PST-8OM-buy-APPL-FV 2child 8food  
 “They have not bought the food for the children.”
- c. *Bilewa bi-a(\*bi)-kol-el-á baana Iddi.* [\*Rel. obj]  
 8food 8REL-N.PST-8OM-buy-APPL-FV 2child 1Iddi  
 “the food that Iddi has bought for the children...”
- d. *Ngyo?a ya-a(\*ya)-yak-w-a na baana.* [\*Passive]  
 9snake 9SM-N.PST-9OM-kill-PASS-FV by 2child  
 “The snake has been killed by children.”

Secondly, the word order between object-marked objects and other dislocated elements, such as indirect objects or adverbials is ordered in a way that suggests that object markers can only be pronominal. Let us begin with the order of indirect and direct object in double object constructions. Generally speaking, the order between two objects in double object constructions is such that the indirect object always precedes the direct one (370a), which is typical of Bantu languages. If the object marker were pronominal and the object-marked object were thus to occupy a dislocated position, we would not expect orders in which the object-marked object precedes the non-object-marked one. Instead, the object-marked object should always follow the non-object-marked one. This is indeed the case in ditransitive clauses in Bembe. In (370b), the indirect object has been object-marked and cannot precede the direct object, which is arguably in argument position. In (370c), in contrast, the object-marked object follows the non-object marked one and is separated from the rest of the clause by an obligatory intonation break.

- (370) a. *Ba-h-ile*            *baana*    *bilewa*.  
           2SM-give-PST    2child    8food  
           “They gave the children food.”
- b. \**Ba-ba-h-ile*            *baana*    *bilewa*.  
           2SM-2OM-give-PST    2child    8food
- c. *Ba-ba-h-ile*            *bilewa* \*(,) *baana*.  
           2SM-2OM-give-PST    8food        2child  
           “They gave them food, the children.”

The same restrictions hold in applicative constructions. Applied (benefactive) objects must precede direct (theme) objects in simple applicative constructions in the absence of object marking (371a). However, object-marked applied (benefactive) objects cannot precede non-object-marked direct (theme) objects, as in (371b). This is explained if the direct (theme) object is in an argument position and the object-marked applied (benefactive) object in a dislocated one. The analysis is also supported by the obligatory intonation break between the non-object-marked object and the object-marked applied (benefactive) object in (371c)

- (371) a. *Ba-a-kol-el-a*                    *baana*    *bilewa*.  
           2SM-N.PST-buy-APPL-FV    2child    8food  
           “They have bought food for/on behalf of the children.”
- b. \**Ba-a-ba-kol-el-a*                    *baana*    *bilewa*.  
           2SM-N.PST-2OM-buy-APPL-FV    2child    8food
- c. *Ba-a-ba-kol-el-a*                    *bilewa* \*(,) *baana*.  
           2SM-N.PST-2OM-buy-APPL-FV    8food        2child  
           “They have bought them food, the children.”

Let us continue with the order of indirect, direct object and time adverbials in the double object construction. Since the latter are always external, the prediction made by a pronominal approach is that object-marked objects should always follow non-object marked objects and time adverbials alike, since preceding them, and hence causing local doubling, would otherwise incur a theta-criterion violation.

- (372) a. *Ba-lo-kol-el-a*            *baana bilewa elya ekolo.*  
 2SM-PST-buy-APPL-FV 2child 8food 9DEM.dist 9night  
 “They have bought children food yesterday.”
- b. \**Ba-lo-ba-kol-el-a*            *baana bilewa elya ekolo.*  
 2SM-PST-2OM-buy-APPL-FV 2child 8food 9DEM.dist 9night
- c. *Ba-lo-ba-kol-el-a*            *bilewa elya ekolo \*(,) baana.*  
 2SM-PST-2OM-buy-APPL-FV 8food 9DEM.dist 9night 2child  
 “They have bought them food yesterday, the children (that is).”

As the examples in (372) show, the prediction is borne out since object-marked objects must follow both non-object-marked objects and time adverbials. As seen in previous examples, an obligatory intonation break marks the boundary of the verb phrase, separating the object-marked object from the rest of the clause.

A final argument comes from the word order of direct (theme) objects and Wh-phrases asking for the indirect (goal) or applied (benefactive) object in applicative constructions. If object-markers were pronominal, and object-marked objects thus dislocated, the latter should not be able to precede in situ Wh-phrases in double-object constructions since the latter are inherently non-topical, as they are non-referential, and are arguably always situated in an argument position. Under an agreement approach, any order between the Wh-phrase and direct (theme) object should be allowed. As (373) illustrates, object-marked objects must follow non-object-marked ones and be separated by an intonation break from the rest of the clause. Thus, the prediction made by a pronominal approach is borne out, while an agreement approach fails to account for the data.

- (373) a. *Ba-a-kol-el-a*            *beni bilewa?*  
 2SM-N.PST-buy-APPL-FV 1who 8food  
 “They have bought food for whom?”
- b. \**Ba-a-bi-kol-el-a*            *bilewa beni?*  
 2SM-N.PST-8OM-buy-APPL-FV 8food 1who
- c. *Ba-a-bi-kol-el-a*            *beni \*(,) bilewa?*  
 2SM-N.PST-8OM-buy-APPL-FV 1who 8food  
 “They have bought it for whom, the food?”

### 3.3.4 Summary

So far, we have determined that object marking in Bembe is not related to any semantic features of objects, such as animacy, humanness, definiteness or specificity. Instead, it has been shown that only discourse-old elements can and, indeed, must be object-marked. Evidence for the claim that object-marked and hence discourse-old elements must be in a dislocated position, has been presented in the form of

- (i) obligatory phonological-phrase boundaries in case of object marking;
- (ii) co-occurrence restrictions between object marking and indefinite, non-referential/focused, relativised, passivised elements and negative-polarity items;
- (iii) the order of object-marked objects with respect to other elements; and
- (iv) a topic interpretation of objects in the presence of object markers.

All of the presented facts point to the conclusion that object-marked objects are always dislocated, and that object marking in Bembe must therefore be pronominal in nature. The fact that lexical objects and object markers have been shown to be in complementary distribution (in the inflectional domain) is hard to account for under a grammatical-agreement approach, which consistently fails to make the correct predictions across a range of different constructions in Bembe. I therefore dismiss an analysis according to which object markers are grammatical agreement markers and treat them as essentially pronominal in nature. This leads us directly to the question as to what kind of pronoun object markers are, which will be the topic of the next section.

### 3.4 The syntactic status of object markers in Bembe

Bresnan (1997, 2001) makes a distinction between full pronouns and reduced pronouns, the latter including bound pronouns and clitics. Whereas free pronouns are used by default to introduce new topics or for reasons of contrast, reduced pronouns are always used to refer anaphorically to a preceding discourse referent. Free pronouns, in turn, are used to identify discourse-old referents only where no bound pronoun is available. This tripartite distinction is reminiscent of Cardinaletti & Starke's (1999; henceforth C&S) typology of pronominal forms, which is based on a set of diagnostics to differentiate between them. They divide pronouns into what they term strong pronouns, weak



pronouns and clitics. While the first counts as a strong form, the latter two are taken to be defective forms. ‘Defective’ is to be understood in the sense of morphological impoverishment: the more morphemes a pronoun has (underlyingly), the stronger it is. C&S contend that morphemes are realised by syntactic heads (cf. Baker 1988). With respect to their syntactic category, strong and weak pronouns are taken to be syntactic phrases, while clitics are heads. A range of further phonological, morphological, syntactic, and semantic facts are presented for distinguishing between the three forms. As far as their syntactic characteristics are concerned, the three pronouns differ in five aspects, (a) their categorial status as XPs or X°: (b) theta-position, (c) coordination, (d) clefting, and, ultimately, (e) modification. Semantically, weak pronouns and clitics differ from strong pronouns in that they need an antecedent in the discourse, i.e. they cannot be used deictically/ostensively. As regards phonology, weak pronouns and clitics differ from strong pronouns in that the former can form a phonological unit with a lexical item while the latter cannot. In what follows, I will apply the diagnostics presented by C&S to Bembe in order to identify the syntactic nature of the object marker.

To begin with, object markers cannot appear in canonical object position, i.e. immediately following the verb, which however is possible for full DPs and strong pronouns. Consider (374).

- (374) a. *Iddi a-lo-mon-a εwe /Ali.*  
 1Iddi 1SM-PST-see-FV 1he/Ali  
 “Iddi saw him/Ali.”
- b. *Iddi a-lo-m-mon-a.*  
 1Iddi 1SM-PST-1OM-see-FV  
 “Iddi saw him.”
- c. \**Iddi a-lo-mon-a m.*  
 1Iddi 1SM-PST-see-FV 1OM  
 (Int. “Iddi saw him.”)

Secondly, as can be seen in (375), object markers cannot be coordinated with other DPs.

- (375) a. *Iddi na ɛwe ba-lo-som-a bitabo.*  
 1Iddi and 1he 2SM-PST-read-FV 8book  
 “Iddi and him read a book.”
- b. \**Iddi na m ba-lo-som-a bitabo.*  
 1Iddi and 1OM 2SM-PST-read-FV 8book  
 (Int. “Iddi and he read a book.”)

In contrast to strong pronouns, object markers cannot be clefted either. Consider the examples in (376).

- (376) a. *A-le Iddi i-wa-a-som-á etabo.*  
 1SM-COP 1Iddi FOC-1REL-N.PST-read-FV 7book  
 “It is Iddi who has read a book.”
- b. \**A-le m i-wa-a-som-á etabo.*  
 1SM-COP 1OM FOC-1REL-N.PST-read-FV 7book  
 (Int. “It is him who read a book.”)

The data so far suggests that object markers in Bembe behave more like defective pronouns than strong ones. This should also be visible with respect to their semantics. Since weak pronouns and clitics need a discourse antecedent in order to be able to refer to someone or something, the omission of an antecedent should result in ambiguity. The same, however, is not true for strong pronouns, as these can be used for deixis/ostension. That this is also the case in Bembe is shown by the contrast between the examples in (377). In (377a), the referent of the lexical object pronoun *bibyó* is not retrievable from the discourse, yet the sentence is felicitous, as strong pronouns can be used deictically/ostensively. In (377b), in contrast, the referent of the object marker *bi* remains ambiguous, as there is no visible antecedent in the preceding discourse nor, more importantly, can object markers be used ostensively. Thus, the semantic test lends further support to the assumption that object markers in Bembe are defective rather than strong pronouns.

- (377) a. *Iddi a-a-kol-el-a baana bibyó.*  
 1Iddi 1SM-N.PST-buy-APP-FV 2child 8them  
 “Iddi has bought them for the children.”

- b. #*Iddi a-a-bi-kol-el-a* *baana*. (Int. context: pointing at books)  
 1Iddi 1SM-N.PST-8OM-buy-APP-FV 2child  
 “Iddi has bought them for the children.”

While we can exclude the possibility of object markers being strong pronouns, the presented diagnostics are not able to differentiate between weak pronouns and clitics. According to C&S, the main difference between weak pronouns and clitics is that weak pronouns can appear in initial position, e.g. as in German, or in a position not immediately adjacent to the verb, e.g. as in Italian. Clitics, in contrast, cannot ever appear in sentence-initial position and have to always appear immediately adjacent to the verb. As is visible from (378), the latter is also true in Bembe: object markers cannot ever appear sentence-initially but must occupy a position immediately adjacent to the verb.

- (378) a. *Ba-lo-bi-som-a*  
 2SM-PST-8OM-read-FV  
 “They read them.”
- b. \**Ba-bi-lo-som-a*  
 2SM-8OM-PST-read-FV
- c. \**Bi ba-lo-som-a*  
 8OM-2SM-PST-read-FV

The properties of Bembe object markers are summarised and contrasted with those of all three types of pronouns in Table 33.

	Canonical position	Co-ordination	Adjacency	Initial position	Deixis/Ostension
Strong pronouns	✓	✓	*	✓	✓
Weak pronouns	*	*	*	✓	*
Clitic pronouns	*	*	✓	*	*
Bembe OM	*	*	✓	*	*

Table 33: PROPERTIES OF BEMBE OBJECT MARKERS

In line with suggestions that clitics are dependent on the presence of a host to which they must attach (cf. van Riemsdijk 1999), I conclude that object markers in Bembe are pronominal clitics rather than strong or weak pronouns. In the next section, I will determine the remaining piece of the puzzle, namely how object markers are represented structurally.

### 3.5 The structural representation of object markers in Bembe

#### 3.5.1 The verb in Bantu

Before reviewing the relevant approaches to clitic placement offered in the literature and decide how to structurally represent object markers in Bembe, I will determine the structural representation of the verb in Bembe. In Romance languages, like French and Italian, the linear order of pre- and suffixes is the mirror image of the structural order of their respective syntactic heads. Thus it is usually assumed that the linear order is the result of head movement of the verb. Consider the derivation (379b) of the example in (379a).

- (379) a. *Am-av-o* (Italian; Giorgi & Pianesi 1997: 69)  
 love-PST-AGR1S  
 “I loved.”

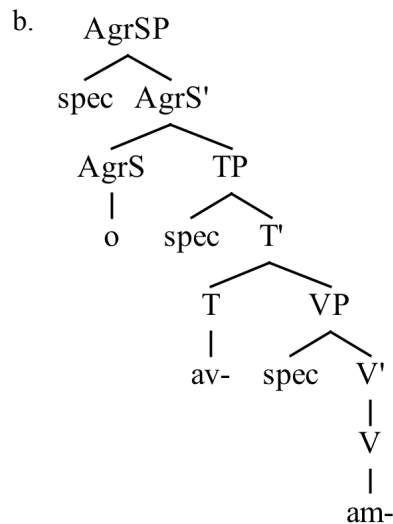

The verb successively head-moves through each projection incorporating the tense and agreement morphemes. Given that head movement is suffixation by left-adjunction

(Kayne 1994), V *am-* moves to T *av-*, incorporating the latter head to form the complex head *am-av*. Subsequently, the complex head moves further to AgrS *o-*, which it also incorporates in order to yield *am-av-o*. The resulting structure is illustrated in (380).

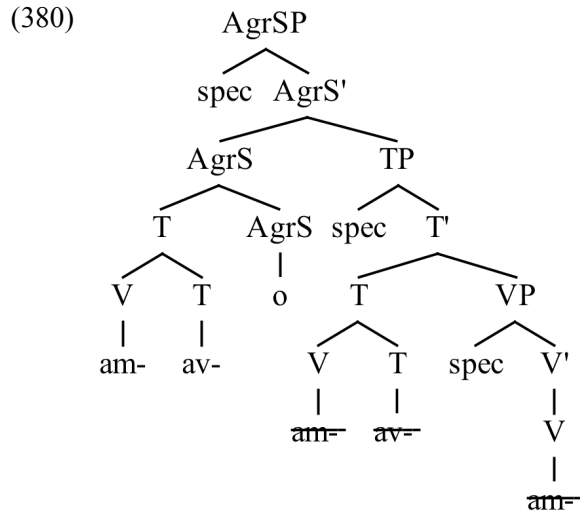

In a similar fashion, it has been claimed for Bantu in more general that the verb moves from V to T (Kinyalolo 1991; Baker 2003, 2008; Carstens 2005 amongst others) and in some cases it has even been claimed that it moves as far as C (Demuth & Harford 1999a,b for Shona). However, one reasons against such an approach is its inability to predict the correct order of verb prefixes and suffixes. Consider (381) in this respect.

- (381) a. *Bitabo bi-a-kol-w-a*.  
 8book 8SM-N.PST-buy-PASS-FV  
 “The books have been bought.”

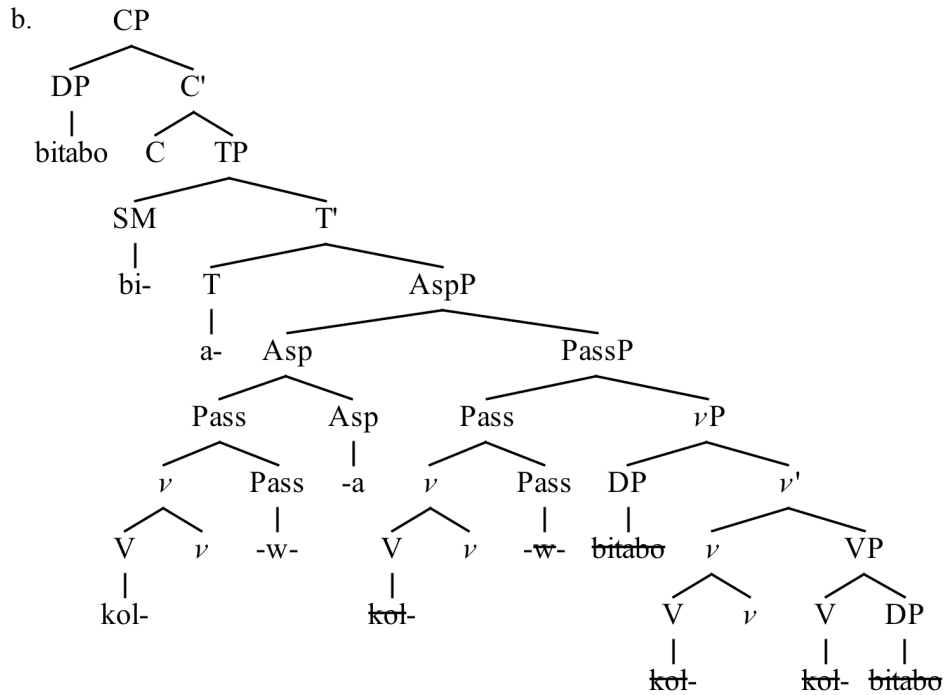

I have already pointed out that with the advent of Kayne's (1994) Linear Correspondence Axiom and his work on the Antisymmetry in Syntax came the assumption that head movement must strictly proceed qua left adjunction. Thus, in (381b), the verb stem *kol-* moves into the PassP to adjoin to the passive marker *-w-*. The so-formed complex head *kol-w* raises further to the head of AspP to adjoin to the final vowel *-a*, thus yielding *kol-w-a*. Now, if the verb were to move further to T (and possibly even further to pick up other morphemes such as subject or relative markers), it would have to left-adjoin to the tense morpheme *a-* (and subsequently to the subject marker *ba-*), giving *kol-w-a-a-ba*. However, as tense and subject markers always precede the verb, this clearly goes against the Bembe facts. In order for V-to-T movement to make the correct predictions, the verb would have to adjoin to the right of the tense and subject marker, *ba-* and *a-*, but to the left of passive and aspectual marker, *w-* and *-a*, respectively. That head movement proceeds in this way, i.e. randomly changing from prefixation to suffixation without following any recognisable principle that determines which marker is prefixed and which one is suffixed, is little more than a restatement of the observation that there are prefixes and suffixes.

An alternative analysis for Bantu which circumvents these problems is provided by Julien (2002), who follows Myers (1990) in assuming that the verb in the Bantu language Shona consists of two separate constituents: on the one hand, the sequence of inflectional prefixes, such as NEG, SM and T, and on the other the verbal stem, i.e. the

verbal base with its derivational suffixes. As opposed to proponents of V-to-T movement, Julien assumes the two different parts of the verb are the result of two different operations: the verbal base with its verbal suffixes is the result of syntactic head-movement, while prefixes are merged with the verb by a morpho-phonological operation. Consider the example in (382).

- (382) [ *Ta-* *-ba-* *-a-* ] [ *yak-* *w-* *a* ].  
           NEG SM T           V       PASS FV  
           “They have not been killed.”

As for the evidence for such a view, Julien cites the difference in linear and structural order between prefixes and suffixes. The linear order of the suffixes in Bantu, illustrated in (382), is the mirror image of the hierarchical order of the associated syntactic heads. According to Pylkkänen (2002, 2008), these associated causative, applicative, passive and aspect/mood/polarity heads (in this order) are higher in the structure than verbal heads in Bantu, strongly suggesting that the surface order is the result of left adjunction, and thus head movement. In contrast, the linear order of prefixes is identical to the underlying order of their associated syntactic heads, which is in line with assumptions about universal hierarchical structure (cf. Cinque 1999). Consider (383).

- (383) a. SM - T - OM – V           [Bantu]  
        b. AgrS/Fin - T - Asp – V     [Cinque 1999]

In the light of the presented criticism with regard to V-to-T movement, I follow Myers (1990), Julien (2002), Kinyalolo (2003), Buell (2005), and van der Wal (2009) in analysing the verb as originating as lexical base in the VP from where it left-adjoins to *v* and forms a complex head consisting of the verb + *v*. This complex head subsequently moves to AspP and left-adjoins to the Asp marker *-a*. Inflectional prefixes, tense and negation morphemes are base-generated as heads in their own functional projections above AspP. In contrast to the verbal stem, i.e. the verbal base plus its suffixes, which together form a complex head as the result of head-movement, the preverbal morphemes are merged by a morpho-phonological operation.

- (384) a. *Ta-ba-a-yak-a*                      *ngyoʔa*.  
 NEG-2SM-N.PST-kill-FV 9snake  
 “They have not killed a snake.”

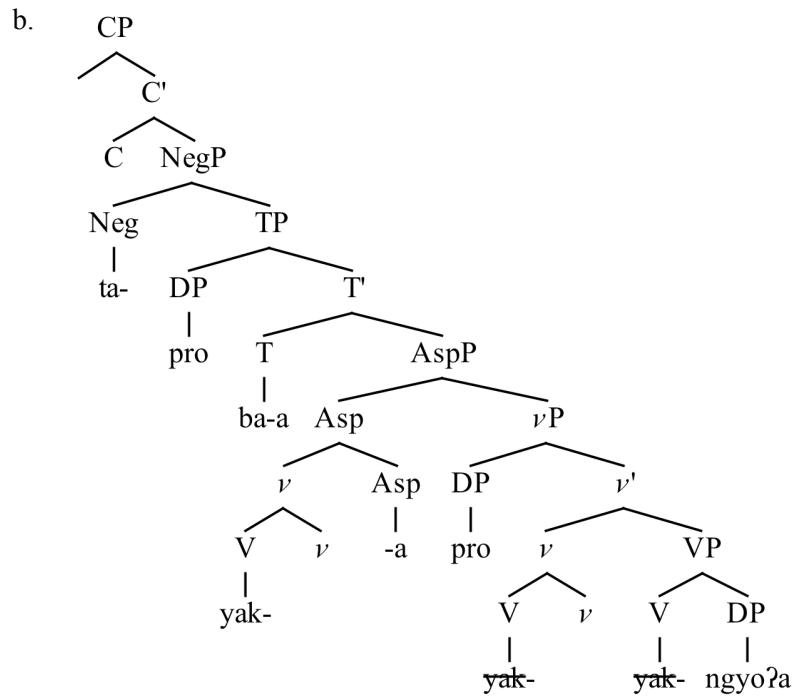

As regards the applicative, causative, passive and other markers, they are sandwiched between AspP and vP, in a manner that the verb incorporates into them while moving towards AspP, where they end up as suffixes on the verb. Consider (385), which illustrates the simultaneous marking of the verb with a causative and a passive marker.

- (385) a. *Ba-a-le-chi-w-a*                      *mleka*.  
 2SM-N.PST-eat-CAUS-PASS-FV 3bean  
 (Lit. “They have been caused to eat beans.”)  
 “S/he has been fed beans.”



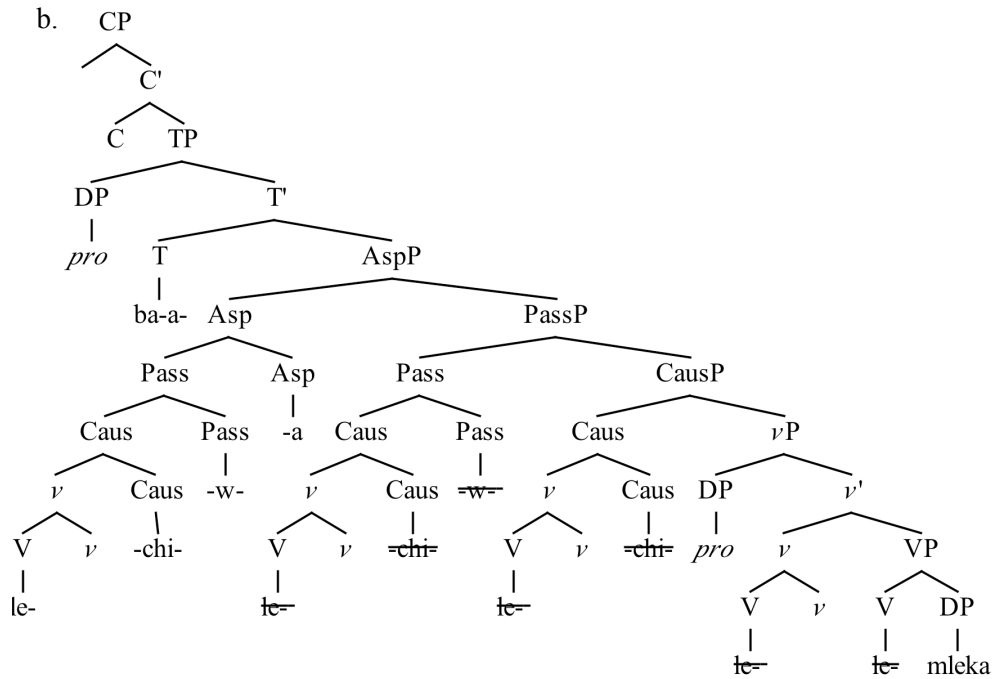

### 3.5.2 Clitic-movement approaches

There are numerous attempts in the literature as to how to represent clitics structurally, which can be roughly divided into three groups: (a) analyses that assume object clitics to be merged in their surface position and to be related to an element in the argument position in differing ways (Jaeggli 1982, 1986; Borer 1984; Suñer 1988; Dobrovie-Sorin 1990), (b) analyses that assume merger of object clitics in argument position and subsequent movement of the clitic to a higher position (Kayne 1975; B&M 1987; C&S 1999; Julien 2002; Nevins 2011; Kramer 2011, 2014; Roberts 2010a,b; Bax & Diercks 2012) and (c) those that attempt to reconcile the two approaches (Sportiche 1992/1996, 1998; Riedel 2009; Uriagereka 1988, 1995). Since the analyses contained under (a) are intended to capture the facts for languages that allow clitic doubling, and are thus incapable of accounting for the complementary distribution of object DPs and object markers, I will base the discussion on the approaches in (b) & (c).

One of the first movement analyses of clitics was proposed in Kayne (1975) (subsequently adopted by C&S 1999). On the basis of French, in which clitic doubling is prohibited, it is argued that clitics are base-generated as NPs in the complement position of the verb.

- (386) a. *Je le vois.* (French)  
 I him see  
 “I see him.”
- b. \**Je le vois Jean.*  
 I him see Jean  
 (Int. “I see Jean.”)

In Kayne (1975) it is claimed that the clitic NP subsequently moves to a preverbal position and forms a complex head with the verb in (386a), as represented in (387). Incorporation of the NP into V is supported by facts such as that the clitic cannot appear isolated, nor can it be stressed or coordinated. In addition, nothing can intervene between the clitic and the verb. The same is argued for Greek by Philippaki-Warbuton (1977, 1987).

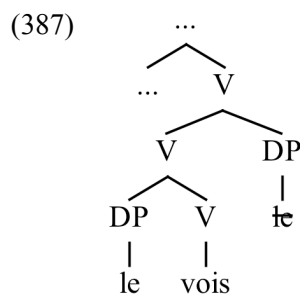

Kayne also contemplates a base-generation and a hybrid analysis but dismisses them on the grounds that they require more theoretical machinery. In addition, if clitics were not initially merged as complements of verbs, we would be left without explanation as to (a) why they can appear only with transitive verbs, and (b) why clitic and lexical object are in complementary distribution. Under a movement analysis, in turn, these facts fall out naturally. For cases in which local doubling is seemingly possible, Aoun (1981, 1985) and Hurtado (1985) claim that Kayne’s analysis can be maintained in languages in which object-marked object DPs can be shown to be dislocated. As we have seen earlier, this is to the case in Bembe. However, in languages in which object-marked object DPs are not dislocated but always occupy an argument position, such an analysis runs into problems because if the clitic is merged in complement position, the question arises as to where the object DP should be merged if its canonical position is already occupied. This is one of the reasons why Jaeggli (1982), (1986), Borer (1984), Suñer

(1988), Dobrovie-Sorin (1990) inter al. advocate direct merger of clitics into their surface positions for languages with clitic doubling. However, there are no good reasons to adopt this analysis for Bembe.

*Julien (2002)*

A Bantu-specific approach to cliticisation is presented by Julien (2002), who largely follows B&M's (1987) and Myers' (1990) analysis of object markers in Chicheŵa and Shona as incorporated pronouns and pro-clitics, respectively. She claims, largely based on data from Shona, that object markers are pronominal, albeit weak pronouns, which originate in the complement position of the verb and subsequently move to a dedicated projection XP, immediately above AspP (originally MoodP). Such an account has the advantage of not running into problems with applicative constructions since movement of the applied (benefactive) object marker is assumed to proceed to a position, which precedes the verb in any case at the end of the derivation. Moreover, it can also account for the fact that if an object marker appears with an object DP, the latter necessarily has to be interpreted as definite to be co-indexed with the object marker. Since it is the object marker that bears the argumental role, the object DP can only be merged in a dislocated position, which goes a long way towards explaining the topic interpretation clitic-doubled object DPs necessarily receive in Bembe.

(388) a. *Baana ba-a-bi-kol-a.*

2child 2SM-N.PST-8OM-buy-FV

“The children have bought them.” (Int.: the books)

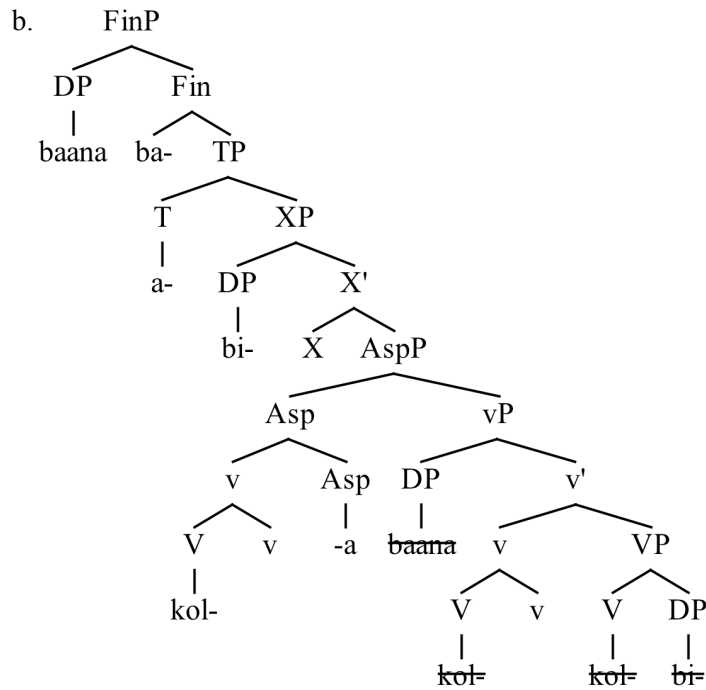

Julien proposes a projection XP hosting the object marker as a way to make clear that the object marker in Shona is associated neither with the so-called verbal stem nor with the preverbal inflectional markers. The fact that object markers never form part of the reduplicated verb stem is taken to be evidence for this. Consider (389).

- (389) *Ndi-nó-mu-kúmbir-a-kumbira.* (Shona; Myers 1990: 48)  
 1SM-HAB-3SG.OM-ask-REAL-REDUP  
 “I keep asking him.”

However, I see three problems with adopting such an account for Bembe, and Bantu in more general. Firstly, the presence of a specifier position in XP raises the question as to why lexical objects or strong pronouns should not be also able to move overtly to that position, in Bembe or in any other Bantu language for that matter. Julien’s motivation for postulating a dedicated projection XP for object markers is based on the observation that, cross-linguistically, weak pronouns tend to raise higher than full DPs or strong pronouns, which is also true for Bembe, as shown in (390).

- (390) a. \**Baana ba-a ngyo?a yak-a.*  
 2child 2SM-T snake kill-FV  
 (Int. “The children killed a snake.”)

- b. \**Baana ba-a*    *εyo*    *yak-a*.  
 2child 2SM-T it    kill-FV  
 (Int. “The children killed it.”)

Secondly, there are formal problems with the analysis. To begin with, Julien does not provide a formal motivation for movement of the object marker to XP apart from the desire to somehow indicate that the object marker should neither be associated with the verbal stem nor with the group of inflectional markers. For her, object marking in Shona is not an agreement phenomenon but pronominal in nature, thus  $\phi$ -feature valuation cannot be possibly the trigger. Let’s assume for the sake of the argument that some feature, say a [TOP]-feature, is responsible for attracting the object marker to XP. Presumably, at the point in the derivation at which the XP is merged, the subject clitic or lexical subject will be closer than any object or object clitic. If this is the case, why then is the object marker attracted and not the subject marker, considering the latter is closer to XP and also attracted by a [TOP]-feature?

Finally, although Julien never claimed that her analysis is capable of giving a unified analysis that is able to explain all instances of object marking across Bantu, and maybe even across languages of other language families, it must be noted that it cannot handle languages that allow local clitic-doubling such as in Swahili. This makes it undesirable in the light of the recent interest in comparative analyses of Bantu verb marking. In regard of these shortcomings, I dismiss Julien’s (2002) proposal of a dedicated projection to which the object marker moves for Bembe.

Before discussing other analyses that have been presented in the literature, I want to draw the attention to an alternative analysis one may want to entertain, according to which the object marker moves to a designated head-position immediately above AspP, say Object-marker Phrase (OmP), albeit without projecting a specifier position. As opposed to Julien’s analysis, the object marker would have to be analysed as head in order to be able to adjoin to a head position, or at least as a minimal-maximal category (cf. Chomsky 1995, Chapter 4). The absence of a specifier would ensure that only object markers (as heads) but not lexical DPs could move to that position, which would derive the ungrammaticality of SOV sentences in Bembe.<sup>27</sup> In addition, the trigger for movement of the object marker could take the form of a [TOP]-feature, thereby ensuring that only object markers be attracted. Consider (391).

---

<sup>27</sup> One possible motivation for the absence of a specifier position could be the fact that the prerequisite for morphological merger is adjacency of heads.

(391) a. *Baana ba-a-bi-kol-a.*

2child 2SM-N.PST-8OM-buy-FV

‘The children have bought it.’ (Int. *bilewa* ‘the food’)

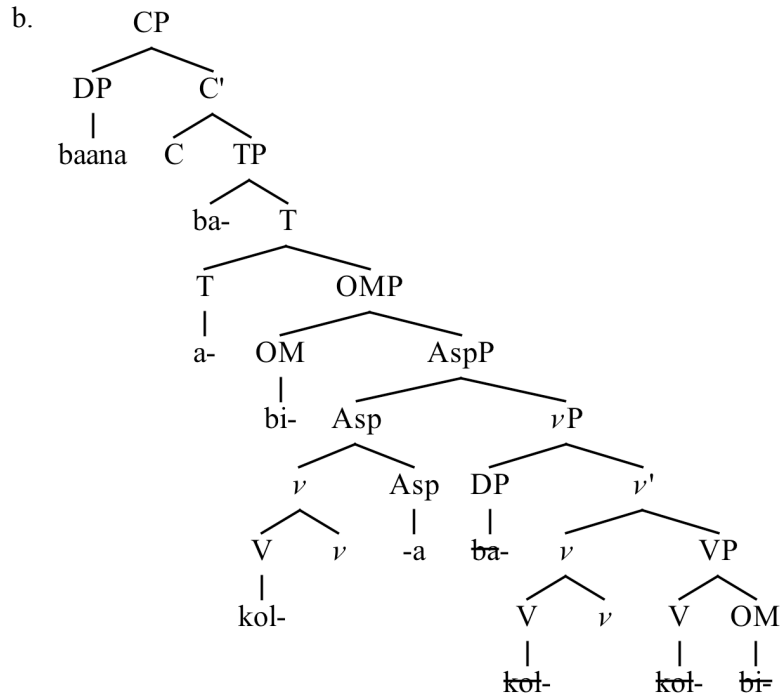

However, while such an analysis would indeed have the advantage of ruling out SOV orders in Bembe by not providing a possible landing site for lexical objects, the earlier-noted problems persist. Firstly, postulating that OMP bears a [TOP]-feature in need of valuation does not ensure that only object markers are attracted. Consider the subject marker, which is still in spec,vP by the time of merging OMP and counts as a suitable goal given its own [TOP]-feature. Since it is actually the closer of the two goals, it should therefore be preferred under the principle of Closest Attract. This, however, is contrary to facts. Secondly, even if we were to disregard this locality violation and assume that the object marker is somehow selected over the subject marker, for instance by assuming that something like the ‘Equidistance Principle’ (Chomsky 1993) holds,<sup>28</sup>

<sup>28</sup> Chomsky (2000: 122) defines the ‘Equidistance Principle’ as in (i).

(i) Equidistance Principle: Terms of the same Minimal Domain are equidistant to probes.

The ‘Minimal Domain’ is the set of all entities contained within one maximal projection, as defined in (X).

(ii) Minimal Domain: The Minimal Domain of a head H is the set of terms immediately contained in projections of H (Chomsky 2000: 123).

(or perhaps an additional feature that satisfies the Full Match requirement and rules in only object markers but not subject markers), it is still questionable why it should not incorporate into the verb at the point in the derivation in which the verbal complex has moved to its final destination (AspP). After all, it is the perfect environment for incorporation, and C&S's (1999) main distinction between weak pronouns and clitics is indeed that the latter must appear immediately adjacent to a verb. Given these shortcomings, I move away from the alternative analysis illustrated in (391b) and turn to another proposal, one that is explicitly motivated by the desire to reconcile movement and base-generation analyses.

*Sportiche (1992/1996, 1998)*

In trying to give an account of French cliticisation, Sportiche (1992/1996, 1998) proposes that clitics are merged in functional heads in their surface positions, while lexical NPs are merged as complements of the verb. In contrast to the analysis by Julien, it is not the case that the object clitic moves in the form of a head, but rather in the form of an XP that subsequently moves covertly to a specifier of a Cl(itic) P(hrase), which hosts the clitic in its head position. Note that Sportiche sees cliticisation as an agreement phenomenon, and the object clitic is thus never ascribed the status of an argument, not even in the case of null objects. In case of null objects, *pro* is assumed to replace the lexical object and move into the specifier position.

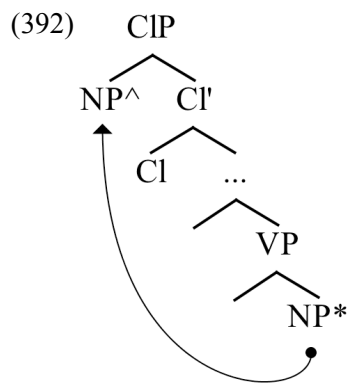

---

By these definitions and assuming a VP-shell structure à la Larson (1988), both direct and indirect object-marker would be in the same Minimal Domain, V in this case, and would thus count as potential goals.

In Chomsky (2001), he abandons the Equidistance Principle in favour of a condition that probes can only access the phonological edge of a phrase. This however would incorrectly rule out attraction of the direct-object marker to the probe. For this to happen, direct-object markers would have to first move from their base-generated position in VP to the edge of the phrase, i.e. a specifier, in order to escape the so-called 'Phase Impenetrability Condition' (Chomsky 2001: 113).

One piece of evidence in favour of his approach comes from participle agreement in French and Italian. The data in (393a) illustrate how clitics can induce agreement on participles, similar to relativised XPs (393b) but not when the object is in a presumably VP-internal position (393c).

- (393) a. *Jean l' a peint(e).* (French; Sportiche 1996: 227)  
 John CL has painted(fem)  
 “John painted it.”
- b. *La porte<sub>i</sub> que Jean a peint(e) t<sub>i</sub>.*  
 The door that John has painted(fem)  
 “The door that John painted...”
- c. *Jean a peint(\*e) la porte.*  
 John has painted(\*fem) the door  
 “John painted the door.”

The question as to why the lexical object moves into the specifier of the projection hosting the clitic is answered with the need to satisfy the General Licensing criterion (394; Sportiche 1992/1996: 68), of which the more specific ‘Clitic Criterion’ in (395) is said to be a sub-criterion.

(394) *Generalised Licensing Criterion*

At LF:

- a. A [+F] head must be in a spec–head relationship with a [+F] XP.
- b. A [+F] XP must be in a spec–head relationship with a [+F] head.

(395) *Clitic Criterion*

At LF:

- a. A clitic must be in a spec–head relationship with a [+F] XP.
- b. A [+F] XP must be in a spec–head relationship with a clitic.

The availability of clitic doubling depends on whether a clitic can co-occur with an overt DP, which is expressed in the form of the *Doubly Filled Voice Filter* (396), comparable to the doubly filled COMP filter which determines whether complementiser doubling is possible in a language (Sportiche 1996: 28).



(396) *Doubly Filled Voice Filter*

\*[HP XP [H...]]

where H is a functional head licensing some property P and both XP and H overtly encode P.

Movement of the doubled object is presumed to either proceed overtly or covertly, depending on the language in question. Thus, clitic doubling takes place when movement of the lexical object to spec,XP can be delayed until LF. The absence of clitic doubling in Bembe would be attributed to covert movement of the lexical object, and, in case of null objects, movement of *pro* to spec,XP. Consider (397).

(397) a. *Baana ba-a-bi-kol-a.*

2children 2SM-N.PST-8OM-buy-FV

‘The children have bought them.’ (Int. *bitabo* ‘the books’)

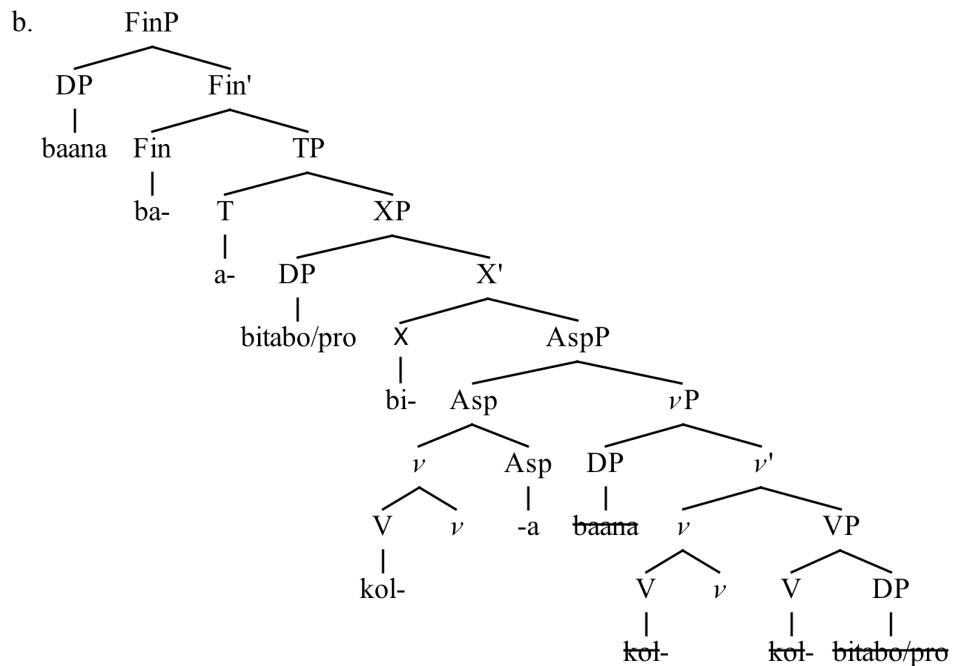

There are a number of problems with Sportiche’s account. We have established earlier that a topic interpretation of the lexical object is obligatory in conjunction with object marking. Thus, the representation in (397b) is incorrect insofar as it allows object marking of focused objects, since these occupy the canonical object position according to Sportiche. However, this is contrary to fact, as object marking of Wh-phrases, for

instance, is ungrammatical in Bembe. Thus, in order to predict the unavailability of local doubling but the availability of non-local doubling with simultaneous topic (in the sense of discourse-old) interpretation of the object in Bembe, one would have to postulate that objects, irrespective of being overt or non-overt, be always generated in a dislocated position, while a null element *pro* would be obligatorily generated as the complement of the verb (à la Baker 2003, 2008). *Pro* would subsequently move into the specifier of the projection hosting the clitic. This is illustrated in (398).

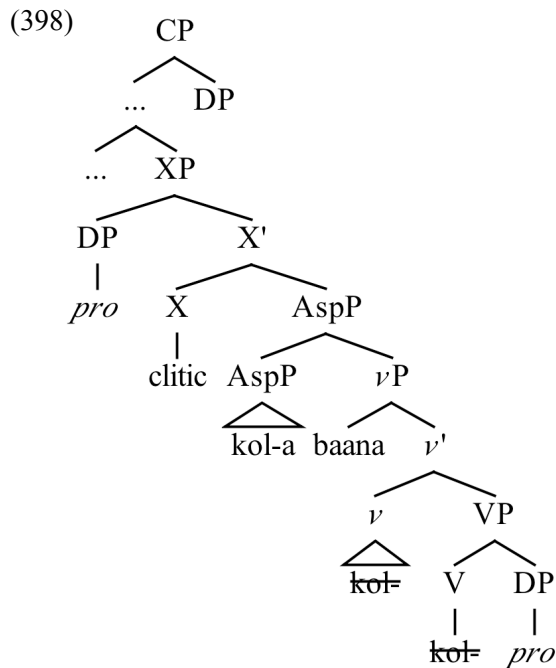

While an analysis with this modification in place would be able to account for the Bembe facts, there remains the more general question as to why exactly a word order in which the lexical object precedes the object clitic (S O OM-V) is unattested in clitic-doubling languages, all the more so given that movement of a lexical object to the specifier of the projection hosting the clitic is in principle possible, and *de facto* obligatory at LF under Sportiche's account.

Also, given that object-marked object DPs are always dislocated and thus a null object *pro* would have to be postulated to be generated as verb-complement, the same would have to be assumed for Wh-phrases. However, the assumption of generating Wh-phrases in dislocated positions is at odds with their inherent non-referential interpretation.

Moreover, Sportiche assumes that a specificity feature is responsible for licensing direct object clitics, thus he treats direct object marking as specificity marking and indirect object marking as proper agreement phenomenon. However, as we have seen, neither direct nor indirect object marking in Bembe show specificity constraints comparable to those claimed by Sportiche. Nonetheless, some feature must be responsible for attracting either *pro* or the lexical object, for instance strong  $\phi$ -features or a [TOP]-feature. However, whichever the responsible feature may be, the analysis suffers from the same problem as Julien's (2002). Under a probe-goal approach to agreement (Chomsky 2000, 2001), a probe cannot just agree with any of the two goals with the same feature-set but instead will choose to do so with the closest one of them (Attract Closest). This leaves Sportiche's analysis unable to explain why the object is attracted to spec,XP despite the fact that, at the time of merging the specifier of XP, the lexical subject or subject clitic in spec,vP is closer to XP than the object.

Finally, note that in Sportiche's analysis it is assumed that subject and object markers are agreement morphology. But by analysing them as belonging to the same category, we would expect them to show an identical, or at least similar, behaviour. This, however, is not the case, as it has been noted that in all Bantu languages subject markers seem to be obligatory as opposed to object markers, which are predominantly optional in the presence of a lexical object. In the light of these shortcomings, I dismiss Sportiche's (1992/1996, 1998) analysis of object marking for Bembe, and turn to another Bantu-specific approach, namely the one presented by B&M (1987).

*Bresnan & Mchombo (1987)*

The criticism brought forward against those approaches which try to reconcile base-generation and movement analyses may at this point entice one to resort to the more traditional movement approaches to clitic placement in order to account for the facts in Bembe. In fact, the majority of analyses, in particular those rooted in Generative Grammar, assume that the clitic is a D or DP/D<sup>o</sup> head, which, depending on the author, moves either to T (Anagnostopoulou 2003), *v* (Nevins 2011; Roberts 2010a,b), F (Uriagereka 1995) or V (B&M 1987).<sup>29</sup> As part of their proposal about the syntax in

---

29 Bresnan and Mchombo have independently from each other modified their respective analyses for object markers in Chicheŵa since their influential (1987) article. Bresnan (1997, 2001) treats them as pronominal affixes, while Mchombo has subsequently referred to them as syntactic objects (1993) and subsequently clitics (1998, 2002). All of these analyses confirm the pronominal status of object markers, and in some way or the other merge object markers in a postverbal argument position, which they subsequently abandon in order to reach their preverbal surface position. As the differences to B&M's (1987) article seem to mainly amount to terminological differences and their focus is on Chicheŵa, I will not take them into account but concentrate on their (1987) analysis.

Chicheŵa, the latter two authors claim that object markers in Chicheŵa are incorporated pronouns, which are merged in argument position as the complement of the verb, and incorporate into the verb under V, thereby forming a complex head. Transposing the analysis into the verb-movement framework by Julien (2002) I introduced above, object markers would subsequently move with V via  $\nu$  to AspP to left-adjoin to the aspect marker *-a*. This is illustrated in (399). (Note that nothing in B&M’s proposal hinges on the position of the subject marker. Thus, for the time being, it will be simply represented theory-neutrally as occupying spec,TP (but see Chapter 4 for a detailed discussion of the issue).

- (399) a. *Ba-a-m-yak-a.*  
 2SM-N.PST-1OM-kill-FV  
 “They have killed him.”

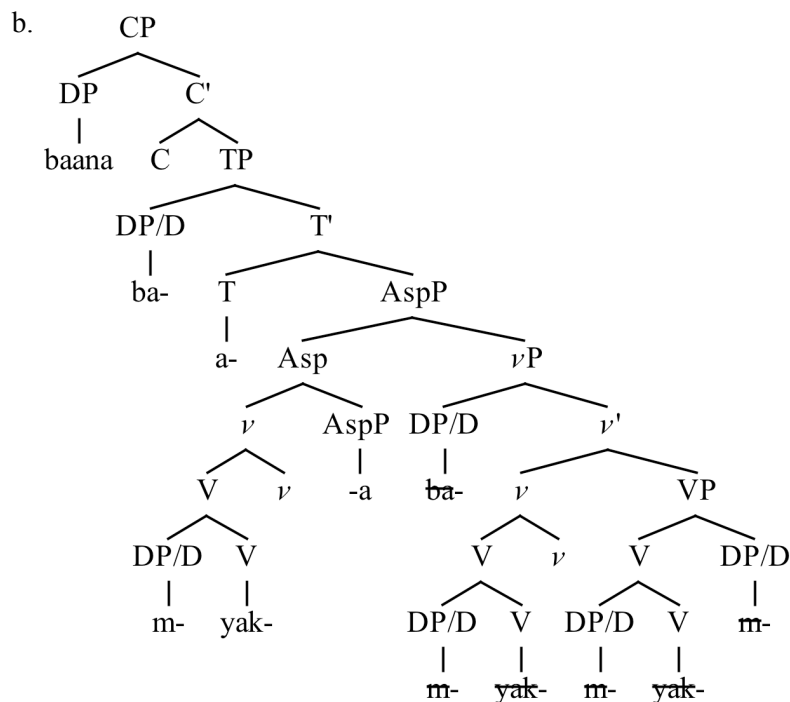

While the analysis above is in principle able to correctly derive transitive clauses in Bembe, it needs to be modified in an important way, as it faces problems once it is applied to double object constructions. Particularly in those constructions in which the indirect object is object marked while the direct one appears overtly, such as in (400). In such cases it is impossible to incorporate the indirect object marker first into the verb and at the same time derive the correct order of verb and object marker, unless it is lowered because it is merged in a position higher than V. However, lowering is widely

assumed to be an illicit operation, as it violates the Extension Condition (Chomsky 1995), according to which every syntactic operation must extend the tree at the root. Furthermore, a head that lowers would never meet the requirement of c-commanding its trace.

- (400) a. *Ba-m-h-ile bitabo.*  
 2SM-1OM-give-PST 8book  
 “They gave him books.”

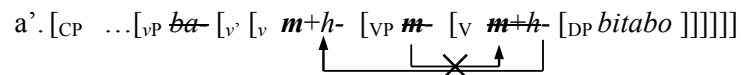

In order to derive the correct order without incurring a violation of the Structure Preservation Condition, the verb would first have to move to *v*, a position to which the indirect object marker could subsequently move in a licit manner, i.e. leftwards, as illustrated in (401).<sup>30</sup>

- (401) a. *Ba-m-h-ile bitabo.*  
 2SM-1OM-give-PST 8book  
 “They have bought books.”

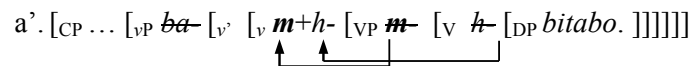

For the sake of convenience, I include the structural representation of (401a) in (402) to illustrate how the problem can be circumvented.

30 Although it does not affect the analysis for Bembe, note that such an approach faces serious problems when applied to languages in which two or more object markers can surface simultaneously on the verb. Riedel (2009) shows that this is the case in Saamba and Haya. In order to derive the correct order of two object markers, i.e. DO > IO, there exists no alternative other than to lower and adjoin the indirect object marker to V, while the direct object marker would have to incorporate into the complex head made up by the indirect object marker and the verb. Thus, in case of two or more possible object markers, we would again be faced with a violation of the Structure Preservation Condition. Thus, arguing from a comparative perspective, the account is far from promising to account for the distribution of object markers in Bantu. However, the core analysis can be upheld for Bembe under the premise that the verb moves first into *v*, followed by incorporation of the direct or indirect object marker into the complex verb head.

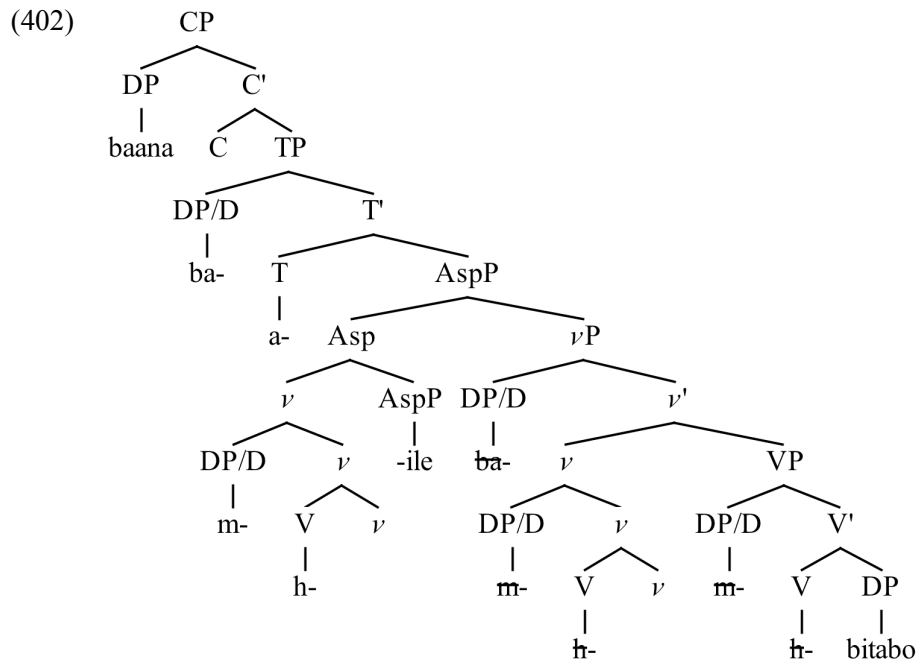

Therefore, B&M's (1987) approach of incorporating the object marker at the earliest point in the derivation cannot be upheld for Bembe, unless it is modified as described above. Interestingly, an analysis modified in such a way is similar to what Roberts (2010) proposes for Romance object clitics, although with the difference that he combines cliticisation with an Agree-based approach.

*Roberts (2010)*

Roberts (2010) follows Holmberg (2005) in recognising that an account of *pro* as being endowed with uninterpretable  $\phi$ -features is incompatible with a probe-goal approach to  $\phi$ -feature valuation as envisaged in Chomsky (2000, 2001), in which the features on T are said to be uninterpretable. Since both sets of  $\phi$ -features would be uninterpretable, derivations involving *pro* would always be doomed to crash. Therefore one of the two must be interpretable. Holmberg (2005, 2010) follows Chomsky in assuming that T has a set of uninterpretable  $\phi$ -features and concludes that the  $\phi$ -features on *pro* must therefore be interpretable, and *pro* hence argumental in nature. Holmberg then goes on to develop an analysis of null subjects for consistent null-subject languages (see Chapter 4).

Applying this by extension to the domain of object marking would mean that the  $\phi$ -features on  $\nu$  should be uninterpretable too. Roberts' (2010a,b) treatment of object clitics in Romance differs in so far from other cliticisation accounts in that he analyses

them as being defective pronouns, i.e.  $\varphi$ Ps (adopting Déchaîne & Wiltschko’s (2002) terminology). Defective is to be understood in the sense of lacking a D-layer, leaving clitics to be nothing else than “the inflectional part of the structure of a pronoun” (Roberts 2010b: 64). As such,  $\varphi$ Ps differ considerably from strong and weak pronouns, which are phrases.<sup>31</sup> Crucially, by being heads rather than phrases, they are able to incorporate into another head, and Roberts claims that incorporation of a  $\varphi$ P into  $\nu$  is a corollary of the operation Agree. In other words, it is nothing else than a way of satisfying the feature-valuation requirements of a probe by a goal. But since the  $\varphi$ -features of the goal are properly included in the  $\varphi$ -features of the probe, i.e. the  $\varphi$ -feature set of the goal is a subset of the  $\varphi$ -feature set of the probe, the result is incorporation, rather than phrasal movement. Roberts (2010b: 65) characterises the process as follows:

- (403) Incorporation can take place only where the features of the incorporee are properly included in those of the incorporation host.

This can be represented as in (404) (adapted in simplified form from Roberts 2010b: 65).

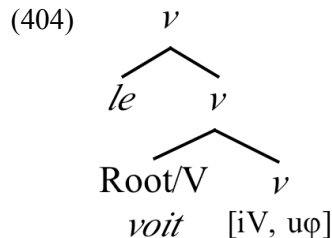

Roberts assumes a formulation of Kayne’s (1994) Linear Correspondence Axiom (LCA), as in (405):

- (405) If  $\alpha$  asymmetrically c-commands  $\beta$ , then  $\alpha$  linearly precedes  $\beta$ .

In the representation in (404), the moved/copied clitic asymmetrically c-commands the target of the movement/copy operation and everything dominated by it. Given the formulation of the LCA in (405), we see then why the clitic must appear to the left of the probe, i.e. “at the edge of the minimal phase” according to Roberts (2010b: 53).

---

31 Admittedly, Robert’s usage of the term ‘ $\varphi$ P’ for defective object clitics may be misleading in that one could be led into thinking that what we are dealing with is a phrase rather than a head. However, as explained above, this is not the case.

How does this incorporation operation work in detail? Consider the example in (406a) and the corresponding derivation in (406b).

- (406) a. *Baana ba-a-bi-ly-a.*  
 2children 2SM-N.PST-8OM-eat-FV  
 ‘The children have eaten it.’ (Int. *bilewa* ‘food’)

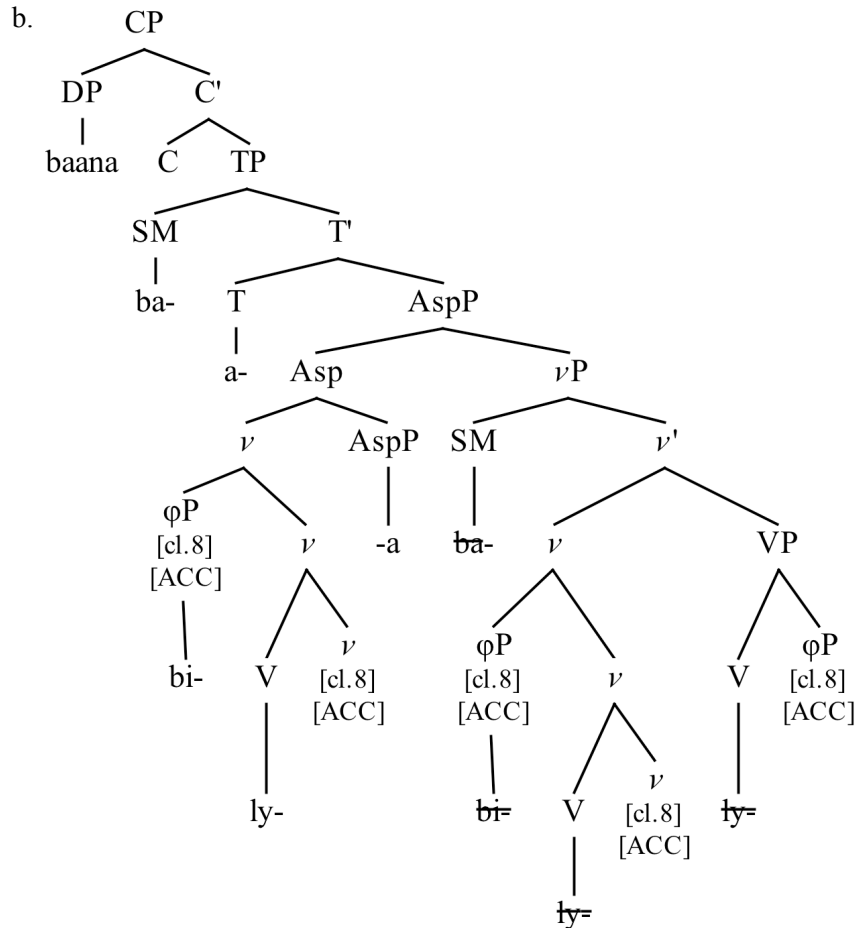

In (406b), the verb moves from V to  $v$ , at which point the finite head  $v$  needs to value its uninterpretable  $\phi$ -features with which it enters the derivation. It subsequently probes for a goal and finds it in the defective  $\phi$ P, which is base-generated as argumental complement to the verb and hence is assigned the theme/patient theta-role by V. The interpretable  $\phi$ -features of the  $\phi$ P subsequently value the unvalued  $\phi$ -features of  $v$ , i.e. class 8. Let us assume for the sake of completeness that  $v$ , in turn, values the unvalued



Case feature [ACC] of the  $\phi$ P.<sup>32</sup> What interests us most here is the result of the feature valuation: probe and goal end up having identical feature sets.

According to Roberts (2010b: 70), when a probe agrees with a goal whose features form a subset of the probe's features, a chain is formed. There are now two identical copies of the probe  $\phi$ P, making it impossible to differentiate the copy operation from ordinary head movement. However, since chain reduction only allows for the pronunciation of the highest copy in the chain, the result is that the lower copies of the defective  $\phi$ P in  $v$ P and VP are not pronounced. What is instead pronounced is the highest member of the chain, which is ultimately spelled out in the form of the [class 8] affix *bi-*.<sup>33</sup>

The chain will receive its referential index from a co-referential (possibly null) object topic in the anterior discourse, i.e. through a chain of topics situated in an A'-position within the C-domain, by virtue of which it will always be interpreted as definite null object with a referential index identical to that of the topic. I adopt Frascarelli's (2007) and Holmberg's (2010: 96) assumption that an A(boutness)-topic is always present in the C-domain, either overtly or covertly, and that the antecedent of the object marker is said null topic directly merged in the C-domain of the clause containing it.

A note on the function of this assumed A-topic is in order here. Admittedly, it seems unlikely that a right-dislocated object should receive its referential index from an Aboutness-shift topic in the sense of Frascarelli (2007) since right dislocation is not associated with providing the context for an assertion but rather with disambiguating an under-specified reference. I therefore assume that another type of topic with some kind of an disambiguating function of under-specified reference is responsible for giving

---

32 That the  $\phi$ P values the unvalued Case features of  $v$  presupposes that abstract Case is existent in Bantu language. This however is an ongoing debate in Bantu linguistics. Roberts (2010: n. 21) notes that if one assumes that clitics lacked an uninterpretable Case feature, this entails a potential violation of the 'Activity Condition' (Chomsky 2001), according to which a goal must have an uninterpretable feature in order to be active for feature valuation. However, Roberts assumes that defective goals do not have to comply with the Activity Condition altogether (pointing to Béjar & Rezac 2009 for evidence) rather than denying them Case. As a consequence, clitics would never cease to be active, which enables him to account for Romance clitic climbing.

Although Case-feature valuation has been included in the representation in (406), I will not discuss the question at this point, as the presented analysis of object marking does not hinge on this. As the question of activity of clitics will be of greater interest in the domain of subject marking (see Chapter 4), and, in particular, with so-called hyper-raising constructions, I will not dwell further upon it but return to the issue in due course.

33 As an alternative explanation as to why the higher copy instead of the lower one is pronounced in the case of  $v$  and the clitic, one could assume that  $v$  has more features than the clitic, namely a verbal feature.

object markers in right dislocations its referential value. The underlying idea however remains the same.<sup>34</sup>

Strong pronouns and DPs, in contrast, cannot incorporate into *v*. In his discussion of subject  $\phi$ Ps in consistent null subject languages, Holmberg (2010) attributes this to the fact that T lacks the corresponding unvalued features of some of the features of lexical DPs. As an example he cites that DPs have roots, the value of which is not relevant under the operation Agree. I cannot see why this should not equally be taken as a possible explanation as to why lexical objects or strong pronouns are blocked from incorporating into *v*. So while strong pronouns and lexical objects will notwithstanding enter an Agree relation with *v* (since the set  $\phi$ -features on *v* is always in need of feature valuation), they will not incorporate due to their D-layer, and the Agree relation will not be spelled out on *v*.<sup>35</sup> Roberts (2010a,b), in turn, attributes the incapacity of strong pronouns and lexical objects to incorporate into *v* to the absence of an EPP-feature on *v*. He claims that if there were an EPP feature, lexical objects would create a specifier for objects to move into in order to value the EPP feature. However, this is not the case, as the word order SOV is unattested in Romance null-subject languages. The same is valid for Bantu languages<sup>36</sup> and Bembe in particular. Hence no EPP-feature is assumed to be present on *v* in Bembe. Both explanations as to why lexical DPs cannot incorporate into *v* can in principle be adopted and the presented analysis does not hinge on this.

The complementary distribution of object markers and lexical objects in transitive sentences falls out naturally under such an analysis, and the obligatory topical interpretation (in the sense of discourse-old) that is associated with object marking in Bembe is accounted for by the argumental status of the object clitics. In the next section, I will determine whether Roberts' analysis is able to account for the object-marking facts in further constructions, namely double-object constructions, i.e. applicative, simple ditransitive and applicative ditransitive sentences, and relative clauses.

---

34 In her discussion of null subjects in Italian, Frascarelli (2007) explicitly argues against the assumption that a topic chain spans across the discourse. Rather, silent copies of referential features of an A-topic are merged in different C-domains. Holmberg (2010: 96) dismisses this as "rhetoric manoeuvre" arguing that "if the null A-topics are copies, then there is a chain-like relation between them, and this relation is established by an operation across sentences in a discourse." I will not comment on this rather technical point, as it would lead us afield from the current discussion.

35 In support of his assumption, Roberts shows that this is able to partially derive Greenberg's Universal 25, according to which a nominal object follows the verb, if the pronominal object follows it (thus the unattested orders  $V > \text{pronoun} \ \& \ O > V$ ). The implications of such a view with respect to null subject constructions in Bembe will be taken up in the next chapter.

36 With the notable exception of the Bantu language Nen (A44) (cf. Nurse 2008: 70).



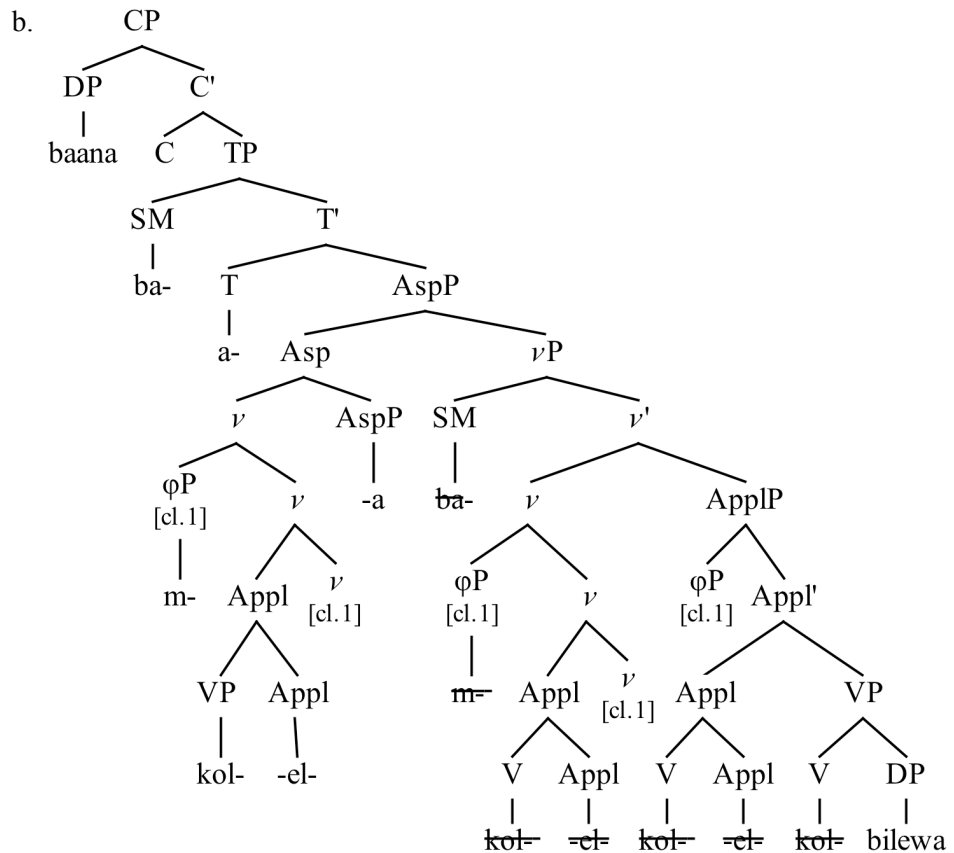

In (408b), I assume that  $\nu$  enters the derivation equipped with a set of unvalued  $\phi$ -features, which probe for a goal. As Roberts (2010a,b) follows Chomsky (2000, 2001) in assuming that probing is downward, the closest goal it encounters will be the applied  $\phi$ P. The features of the applied  $\phi$ P are a subset of the features of  $\nu$ . They will thus enter an Agree relation, in the process of which the applied  $\phi$ P is copied and incorporated into  $\nu$ . Two identical copies of the applied  $\phi$ P now exist and form a chain, making it impossible to differentiate the copy operation from ordinary head movement. Since only the highest copy of a chain is pronounced, the incorporated applied  $\phi$ P is ultimately spelled out in the form of an class 1 object marker *m-*. The applied  $\phi$ P receives its referential index from the (alternatively null) object topic that is merged in the C-domain and will always be interpreted as definite null applied object with a referential index identical to that of the topic in CP. I assume that the applicative  $\phi$ P gets assigned the role of beneficiary and inherent dative case by the applicative head, since the verb *i-kola* ‘to buy’ only sub-categorises for two arguments.

The derivation for applicative constructions in which the direct object is expressed in the form of an object marker proceeds in a similar fashion, with the difference that it is now the  $\phi$ P in direct (theme)-object position that incorporates into  $\nu$ . Consider (409a-b).

- (409) a. *Baana ba-a-bi-kol-el-a Iddi.*  
 2child 2SM-N.PST-8OM-buy-APPL-FV 1Iddi  
 “The children have bought it on behalf of/for Iddi.” (Int. *bilewa* ‘food’)

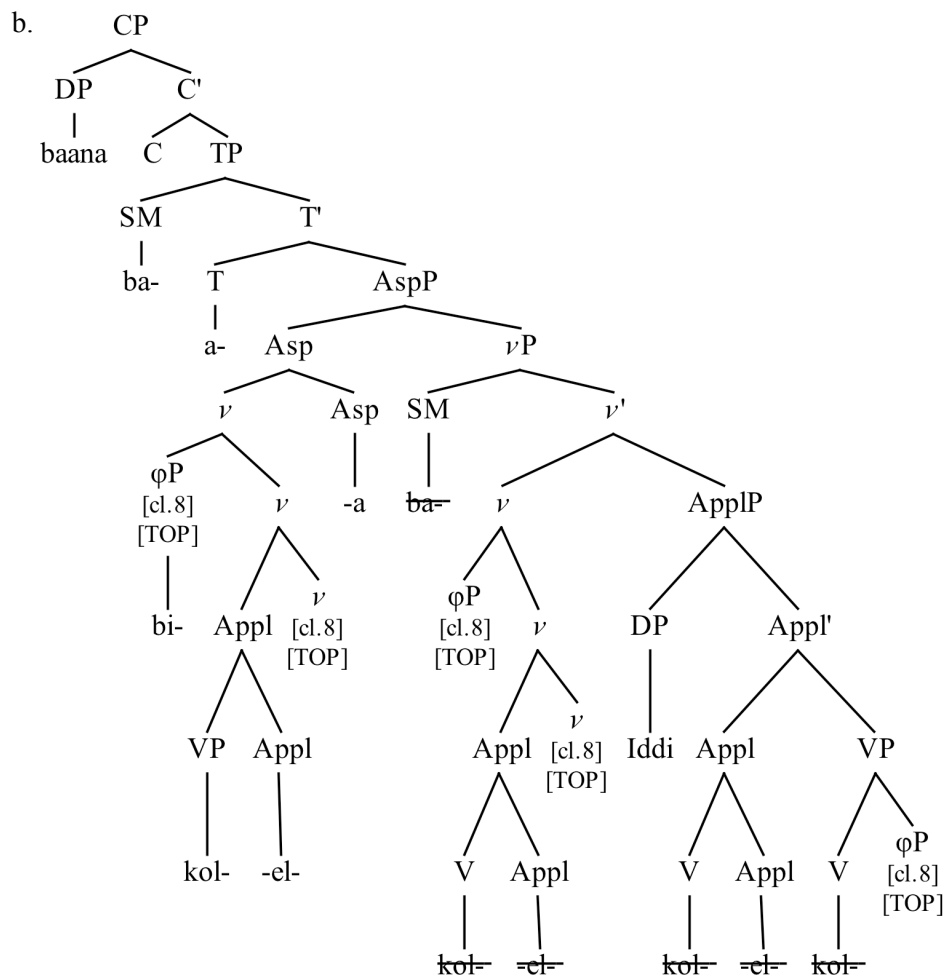

As opposed to (408b), the direct (theme) object in (409b) is generated as a  $\phi$ P in verb-complement position. After the complex head consisting of the verb and the applicative marker adjoins to  $\nu$ ,  $\nu$  probes for a goal and finds the closest goal in the applied (benefactive) object DP *Iddi*. In order to prevent  $\nu$  from choosing the applied (benefactive) object DP as closest goal for an Agree relation, we have to postulate that there is an unvalued [TOP]-feature on  $\nu$ , and the requirement that the operation Agree

requires that all features between probes and goal match, i.e. Full Match. Since the applied object DP is not interpreted as a topic and lacks a corresponding unvalued [TOP]-feature, *v* will continue probing until it finds the class-8  $\phi$ P within the VP. Given that the class-8  $\phi$ P is interpreted as topic, I assume that it has a [TOP]-feature, which together with its set of interpretable  $\phi$ -features matches the unvalued  $\phi$ -feature set and the postulated unvalued [TOP]-feature on *v*. The  $\phi$ P thus values the unvalued  $\phi$  and [TOP]-features of *v*, in the course of which the  $\phi$ P incorporates into *v* forming a complex head with it, since its features are a subset of the features of *v*. The formed constituent *bi-kol-el-* then moves to AspP, yielding the correct output *bi-kol-el-a*. The applied (benefactive) object DP remains in its base-generated position, i.e. in the specifier of ApplP, and since the verb has moved across it to AspP, we derive the correct word order. The presented analysis is able to account for the distribution of object markers and lexical objects in applicative constructions in Bembe under the additional assumption that a [TOP]-feature is relevant for feature valuation. The latter is subject to a Full-Match requirement which dictates that for a probe to agree with a goal, all their features, i.e.  $\phi$  and [TOP]-features, have to match. Next, I will consider whether this analysis can be extended to simple ditransitive sentences.

#### *Ditransitive sentences*

We have already seen that only a few proper ditransitive verbs exist in Bembe, i.e. verbs which do not need an applicative morpheme to license two object arguments. One of them is the verb *i-ha* ‘to give’. Remember that, just as with applicative constructions, either object-marked object must precede the non-object-marked one, and object-marked objects must be separated by an intonation break from the rest of the clause. Structurally speaking, ditransitive sentences are comparable to applicative sentences, with the exception that an ApplP is not projected and that indirect objects are merged in spec,VP rather than spec,ApplP. Consider the example in (410), in which the indirect object appears as a class 1 object marker on the verb, and the lexical indirect object can only appear sentence-finally, separated from the rest of the clause by an intonation break.

- (410) a. *Baana ba-m-h-ile bitabo \*(,) Iddi.*  
 2child 2SM-1OM-give-PST 8book 1Iddi  
 “The children gave him the books, Iddi (that is).”

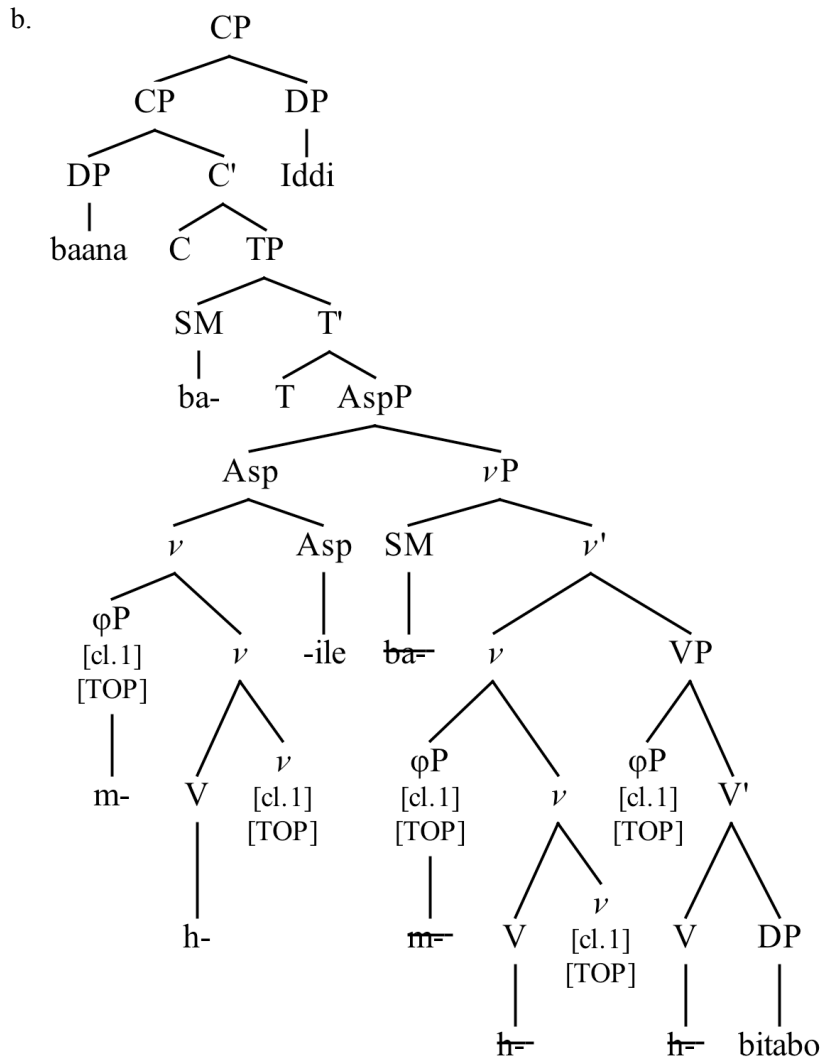

In (410b), the verbal head in V moves to  $\nu$  and forms the complex head consisting of  $V+\nu$ . The set of  $\phi$ -features on  $\nu$  probes for a suitable goal and finds it in the indirect (goal) object  $\phi$ P, which occupies its base-generated position, spec,VP. The latter will value the  $\phi$ -features of  $\nu$  and, in turn, receive dative case from  $\nu$ . Since the features of the  $\phi$ P form a subset of the features of  $\nu$ , the  $\phi$ P incorporates into  $\nu$ . As a result of assuming a copy theory of movement, there are two copies of the  $\phi$ P, one in its original position and one under  $\nu$ . Of these two copies, however, only the highest member of the chain will be pronounced, which is ultimately spelled out as the class 1 object marker *m-* on the verb. Strictly speaking, it is not necessary for the derivation of (410) to assume an unvalued [TOP]-feature on  $\nu$  to ensure that Agree with the indirect (goal)  $\phi$ P, as we have seen that the  $\phi$ -features of the indirect object  $\phi$ P are the closest goal for the  $\phi$ -features on  $\nu$  by default.

However, consider the case of a ditransitive sentence in (411), in which the direct (theme) object appears as an object marker on the verb while the indirect (goal) object is lexical.

- (411) a. *Baana ba-bi-h-ile Iddi \*(,) bitabo.*  
 2child 2SM-8OM-give-PST 1Iddi 8book  
 “The children gave them to Iddi, the books (that is).”

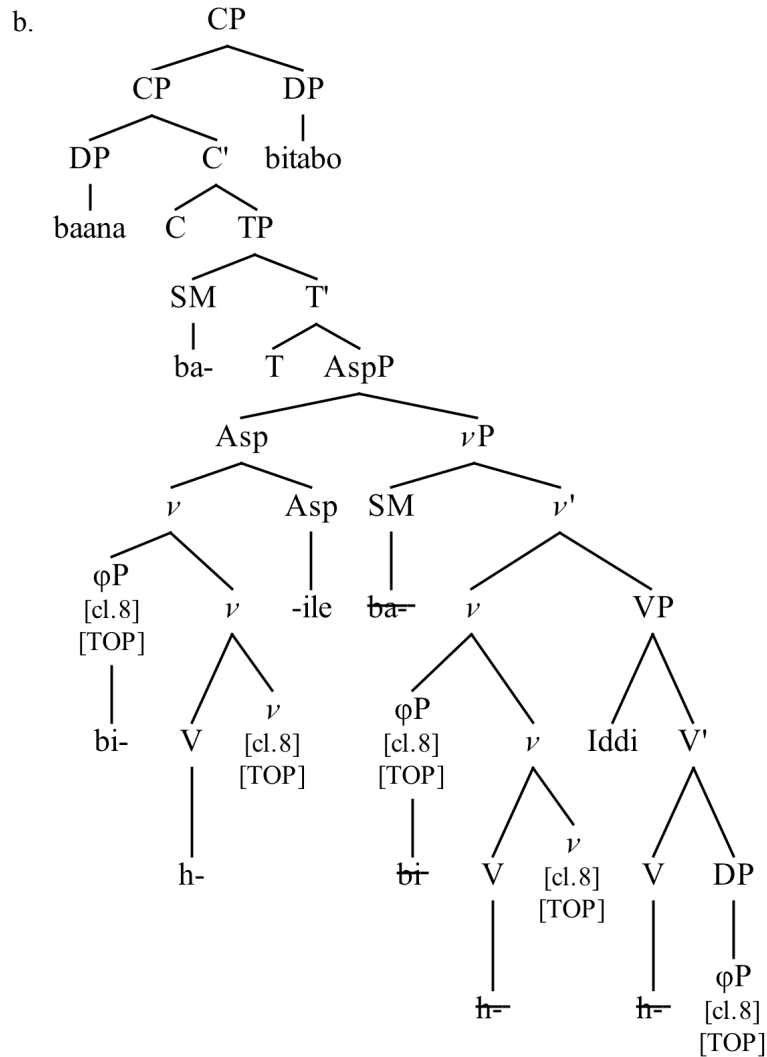

Given that the indirect (goal) object in the representation in (411b) in spec,VP is closer to  $v$  than the direct (theme) object  $\phi$ P in verb-complement position,  $v$  should choose the former over the latter to agree with, which would derive the wrong result. If, however,  $v$  is stipulated to additionally be equipped with a [TOP]-feature, we ensure that  $v$  will select the direct (theme) object  $\phi$ P over the indirect (goal) object to establish an Agree



relation. As a first step, the verb moves from V to  $v$ , at which point  $v$  will seek a goal with matching features. Assuming probing is downward and Full Match as a prerequisite for feature valuation, it will choose the direct (theme) object  $\phi$ P over the indirect object DP in spec,VP since the former enters the derivation with an interpretable [TOP]-feature in addition to its set of interpretable  $\phi$ -features. The direct (theme) object  $\phi$ P will value the [ $\mu$ TOP] and  $\mu\phi$ -features of  $v$ , which in turn will value the  $\mu$ Case feature of the direct object  $\phi$ P with [ACC] case. The result is the same as before: the features of the direct object  $\phi$ P form a subset of the features of  $v$ , as a consequence of which the direct object  $\phi$ P incorporates into  $v$ . Assuming a copy theory of movement, there are two copies of the  $\phi$ P, one in its original position and a higher one under  $v$ , of which only the highest member of the chain will be pronounced, which is ultimately spelled out as the class-8 direct-object marker *bi-* on the verb. Subsequently, the verb moves to its final destination AspP, while the indirect (goal) object DP stays in its base-generated position, which – ignoring the final steps of the derivation – allows us to derive the correct object-marking facts.

We see then that in order to derive the two possible types of ditransitive clauses, an unvalued [TOP]-feature has to be stipulated to be present on  $v$  in conjunction with the prerequisite that the operation Agree requires Full Match, in order to ensure that the direct (theme) object  $\phi$ P is selected over the indirect (goal) object in those cases in which the latter appears as DP.

#### *Ditransitive sentences with applicatives*

Ditransitive verbs in Bembe can also bear an applicative extension, in which case the verb sub-categorises for an additional, fourth argument, the semantic role of which is that of a beneficiary. It is in such constructions, in particular, that the importance of information-structural categories and their syntactic implementation in the form of an unvalued [TOP]-feature on  $v$  in Bembe becomes apparent. Consider the example in (412), in which the direct (theme) object is replaced by a corresponding class-8 object marker on the verb, and the representation in (413), which illustrates the derivation of the example in (412).

- (412) *Baana ba-a-bi-h-el-a Iddi batu \*(,) bitabo.*  
 2child 2SM-N.PST-8OM-give-APPL-FV 1Iddi 2man 8book  
 “The children have given them to the men on behalf of Iddi, the books (that is).”

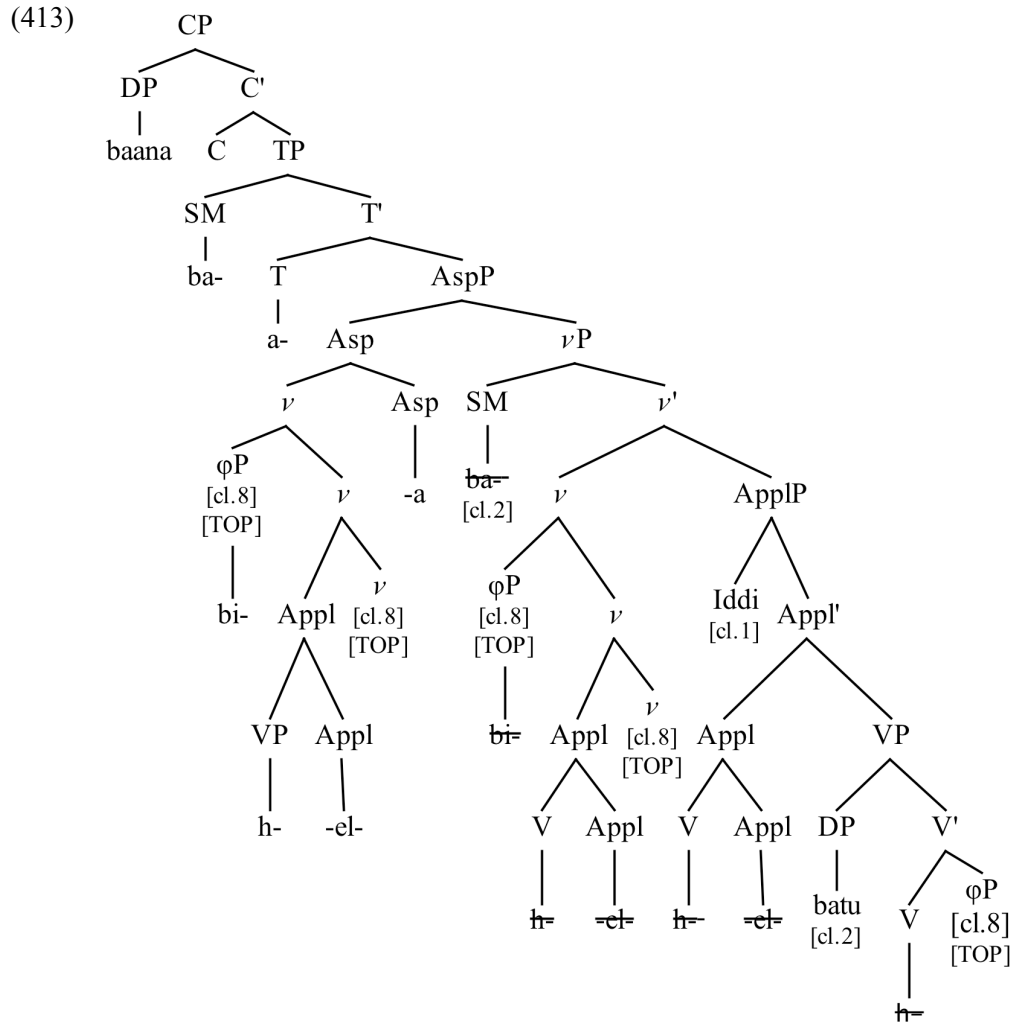

The verb root is generated with its direct complement, i.e. the class 8 φP, under V', and the indirect class 2 object DP *batu* in spec,VP. An ApplP is merged with the applicative morpheme *-el-* as its head. The applied class 1 object DP *Iddi* is generated in the specifier of ApplP, where it is assigned the role of beneficiary and inherent dative case by the applicative head, since the verb *i-ha* ‘to give’ only sub-categorises for three arguments. Subsequently a νP is merged which introduces the light verb *ν* and the class 2 subject marker *ba-* in its specifier. Once *ν* is generated, it will probe for a goal with matching φ-features. Now, if φ-features were the only relevant features for the process

of feature valuation of  $v$  in Bembe,  $v$  would choose the applied object DP *Iddi* since it is the closest goal with a set of matching interpretable  $\phi$ -features, with the result that the Agree relation would not be spelled out. This, however, would be an incorrect result, as the verb displays class 8 object marking.

Given that the object marker on the verb is the class-8 marker *bi-*, we know that the verb has to agree with the direct (theme) object  $\phi$ P in verb-complement position. Thus, if one postulates that  $v$  additionally bears an uninterpretable [TOP]-feature, which is in line with the fact that the referent expressed by the class-8 object marker *bi-* is obligatorily interpreted as being discourse old, and that feature valuation of  $v$  in Bembe requires Full Match,  $v$  will choose the direct (theme) object  $\phi$ P as closest goal, since it enters the derivation equipped with a set of interpretable  $\phi$ -features and a [TOP]-feature. Since the  $\phi$ -features of the direct object  $\phi$ P form a subset of the feature set of  $v$ , the  $\phi$ P will incorporate into  $v$ . Two copies of the  $\phi$ P exist now and form a chain, of which only higher of the two  $\phi$ P copies is spelled out as class 8 object marker *bi-*.

The remainder of the derivation is of minor importance at this point. Suffice it to say that one could assume that the subject DP, if present, finds its place in spec,CP (thereby accounting for its topic properties; see Chapter 4), whereas the subject marker moves from spec, $v$ P to spec,TP. More importantly, however, we have seen that an additional feature in the form of an unvalued [TOP]-feature on  $v$ , and the presence of an interpretable counter-part on the goal, is necessary in order to derive the correct result. This is illustrated in the revised representation in (414), which reflects this insight.

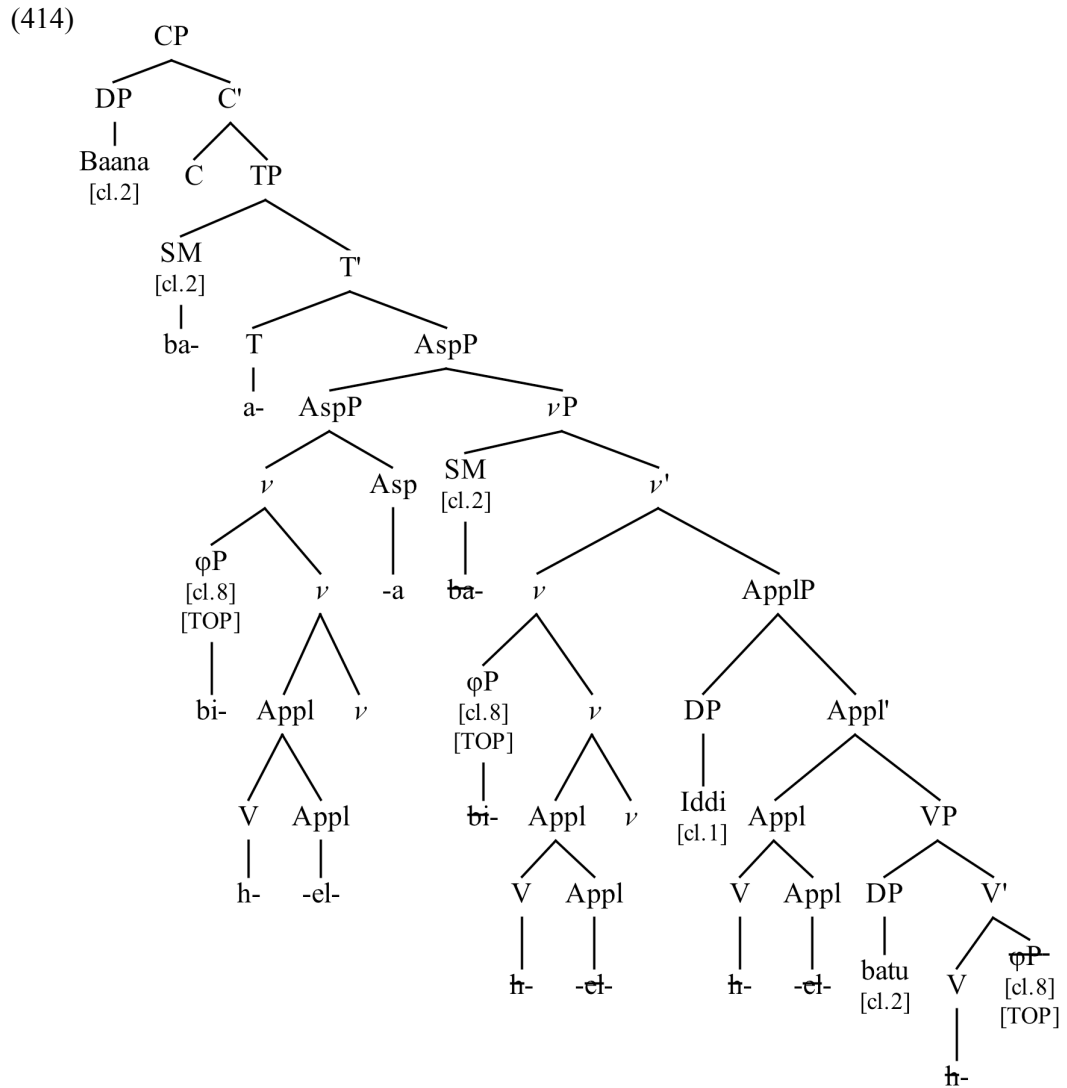

*Subject relative clauses*

Both direct (theme) as well as indirect (goal) objects can be replaced by object markers in subject relative clauses. The example in (415b) shows a subject relative clause in which the indirect (goal) object is expressed as object marker, while (415c) illustrates the use of an object marker for a direct (theme) object.

- (415) a. *mtu wa-h-ilé Iddi bitabo*  
 1man 1REL-give-PST 1Iddi 8book  
 “the man who gave Iddi books”
- b. *mtu wa-m-h-ilé bitabo \*(,) Iddi*  
 1man 1REL-1OM-give-PST 8book 1Iddi  
 “the man who gave him books, Iddi (that is)”

c. *mtu wa-bi-h-ilé Iddi \*(,) bitabo*  
 1man 1REL-8OM-give-PST 1Iddi 8book  
 “the man who gave them Iddi, the books (that is)”

I assume that the derivation of the ditransitive subject relative clause in (415b) is similar to the derivation of the ditransitive sentence illustrated in (410b), with the difference that no subject marker figures in the structure. Consider (416).

(416) a. *mtu wa-m-h-ilé bitabo \*(,) Iddi*  
 1man 1REL-1OM-give-PST 8book 1Iddi  
 “the man who gave him books, Iddi (that is)”

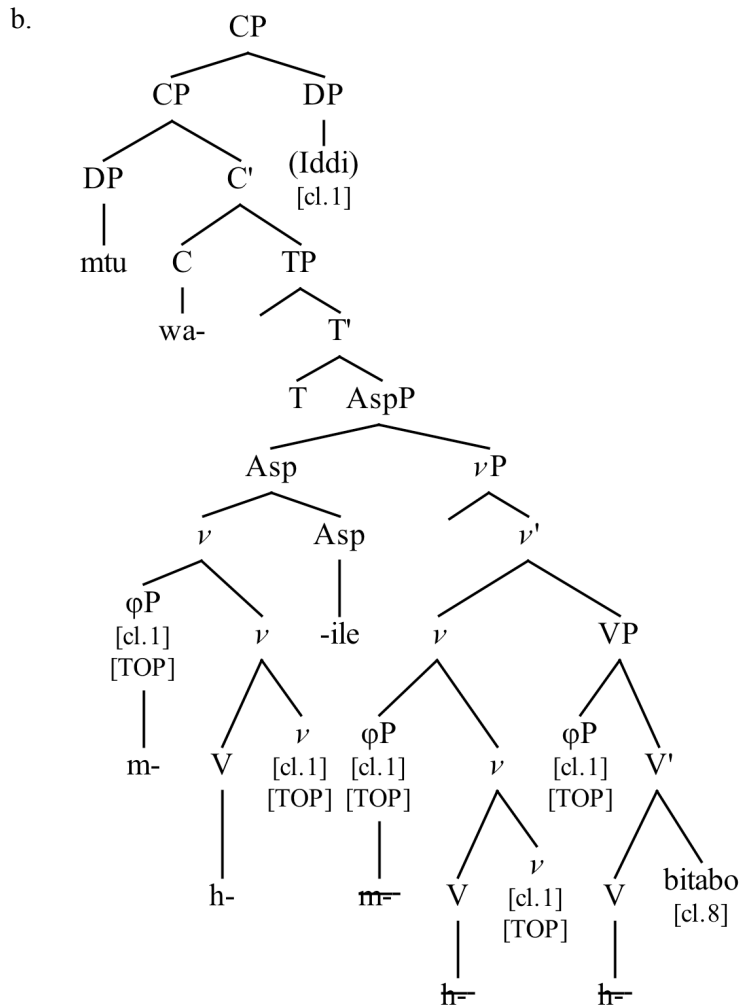

In (416) the verb moves from V to  $\nu$ , after which  $\nu$  probes for a goal, which it will find in the indirect (goal) class 1 object marker in spec,VP, which I assume is introduced as  $\phi$ P into the derivation. The unvalued  $\phi$ -features and [TOP]-feature on  $\nu$  match the set of

$\phi$  and [TOP]-features of the indirect  $\phi$ P, as a result of which the latter will agree with  $\nu$  and incorporate. Of the two copies of the  $\phi$ P, which form a chain with  $\nu$ , only the highest member will be pronounced. As a consequence, the object marker appears to the left of the verb. The so-created complex head, including the object marker and the verb, then moves on to its final destination AspP.

For the alternative of replacing the direct (theme) object in a subject relative clause with an object marker, consider the representation in (417).

- (417) a. *mtu wa-bi-h-ilé Iddi \*(.) bitabo*  
 1man 1REL-8OM-give-PST 1Iddi 8book  
 “the man who gave them to Iddi, the books (that is)”

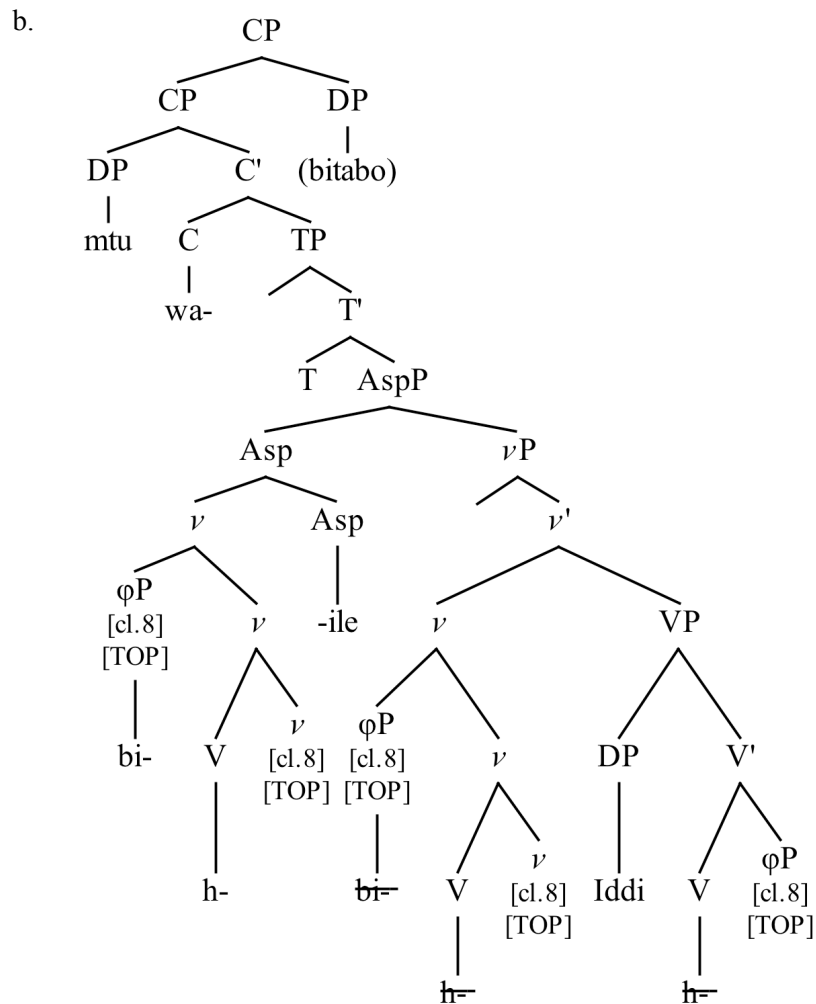

In (417) the verb moves from V to  $\nu$ , after which  $\nu$  probes for a goal, which it will find in the indirect (goal) object marker in spec,VP. However, since it is my assumption that

feature valuation of  $v$  requires Full Match but the indirect (goal) object lacks the necessary [TOP]-feature, it will not be chosen as goal by  $v$ . Probing continues until  $v$  encounters the direct (theme) object in verb-complement position, which I assume is introduced as  $\phi$ P into the derivation. The unvalued  $\phi$ -features and [TOP]-feature on  $v$  match the set of  $\phi$  and [TOP]-features of the direct  $\phi$ P, as a result of which the latter will agree with  $v$  and incorporate. Of the two copies of the  $\phi$ P, which form a chain with  $v$ , only the highest member will be pronounced. As a consequence, the higher  $\phi$ P appears as class-8 object marker *bi-* to the left of the verb. The so-created complex including the object marker and the verb then moves on to adjoin to the final suffix *-ile* under AspP.

### *Object relative clauses*

We have already seen in Chapter 2 that there exist two ways of forming an object relative clause in Bembe: one in which the subject marker figures on the verb but a simultaneous, co-referential lexical subject results in ungrammaticality, referred to as Type 1 object-relatives in this thesis. The opposite scenario, one in which a lexical subject obligatorily figures in postverbal position while a subject marker is barred from appearing simultaneously, I refer to as Type 2 object-relatives. The two types are exemplified in (418).

- (418) a. *ngyo?a ya-ba-(\*ya)-yak-ile* [Type 1 object relative]  
           9snake 9REL-2SM-9OM-kill-PST  
           “the snake which they killed”
- b. *ngyo?a ya-(\*ya)-yak-ile baana* [Type 2 object relative]  
           9snake 9REL-9OM-kill-PST 2child  
           “the snake which the children killed”

In both cases, the relativised object cannot be object-marked, which has earlier been taken as an argument for the pronominal status of object markers. The absence of object-marking is explained if one assumes a traditional analysis to relative clauses, according to which the relativised object starts out in verb-complement position, and thereby already occupies the position which would otherwise be taken up by an object marker. For the issue at hand, we shall abstract away from the distributional facts relating to subject markers and subject DPs and concentrate on object markers for the time being. Since in the here-presented analysis nothing hinges on the nature of the subject marker or the exact structural position of subject DPs, I will postpone a

discussion of these issues until Chapter 4. Now, consider the example of a Type 2 object-relative clause in (419a) and how its derivation looks like up to the moment AspP is merged into the structure, illustrated in (419b).

- (419) a. *ngyoʔa ya-(\*ya)-yak-ile baana* [Type 2 object relative]  
 9snake 9REL-9OM-kill-PST 2child  
 “the snake which the children killed”

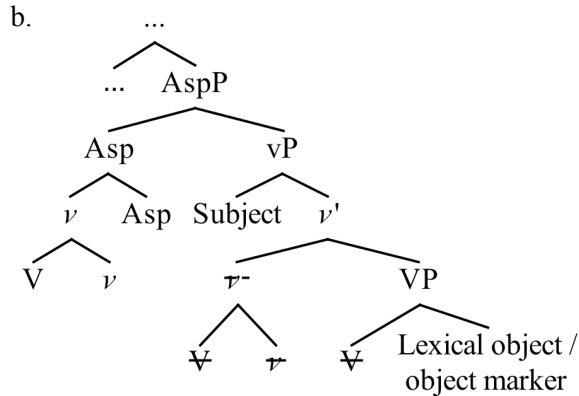

Since we have already established that lexical objects and object markers are in complementary distribution, and knowing that in standard generative analyses object DPs move from their base-generated position into the left-periphery (the exact position we leave open for now), the absence of object marking, and hence the absence of any instance of incorporation, in the derivation in (419a) follows naturally from an account that takes object markers to be pronominal elements.

However, in ditransitive or applicative relative constructions, the object that does not undergo relativisation can be omitted and expressed through a corresponding object marker. Consider the examples of object relative clauses with ditransitive verbs in (420), in which the non-relativised direct (theme) object is expressed through the class 8 object marker *bi-*.

- (420) a. *mtu wa-ba-bi-h-ile \*(,) bitabo*  
 1man 1REL-2SM-8OM-give-PST 8book  
 “the man to whom they gave them, the books (that is)”
- b. *mtu wa-bi-h-ile baana \*(,) bitabo*  
 1man 1REL-8OM-give-PST 2child 8book  
 “the man to whom the children gave them, the books (that is)”



The representation of (420b) is given in (421).

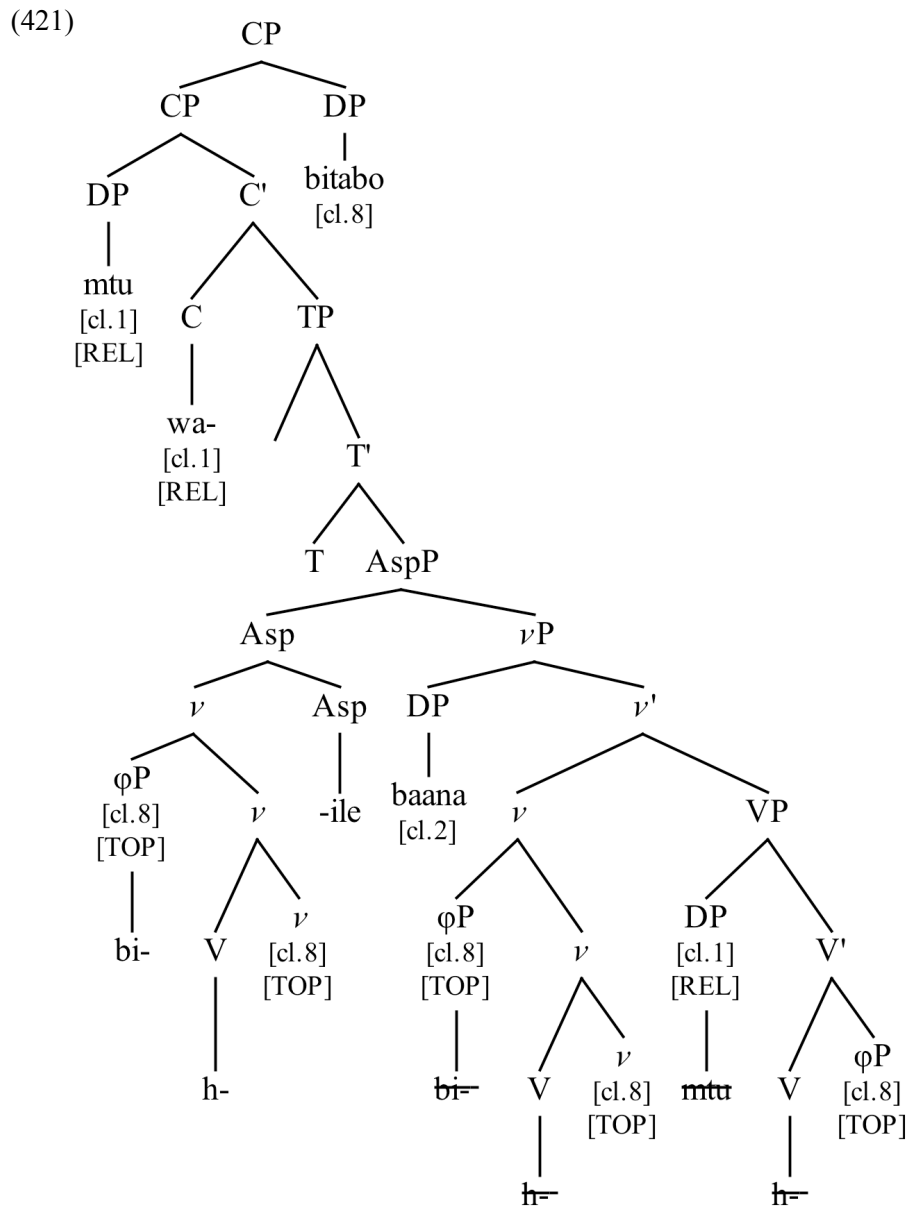

In (421), the verb moves from V to  $\nu$ , after which  $\nu$  probes for a goal, which it will find again first in the indirect object DP *mtu* in spec,VP. Besides a set of interpretable  $\phi$ -features, the indirect object is equipped with a [REL]-feature, which is presumably responsible for raising it into a position within the left periphery, reserved for relativised elements. However, the [REL]-feature is not relevant for the feature valuation requirements of  $\nu$ , and since one of my working assumptions is that feature valuation requires Full Match, the indirect object will not be chosen as goal by  $\nu$  because it lacks

the necessary [TOP]-feature. Probing by  $v$  continues until it encounters the direct (theme) object in verb-complement position, which I assume is introduced as  $\phi$ P into the derivation. The unvalued  $\phi$ -features and [TOP]-feature on  $v$  match the set of  $\phi$ -features of the indirect  $\phi$ P, as a result of which the latter will agree with  $v$  and incorporate. Of the two copies of the  $\phi$ P, which form a chain, only the highest member will be pronounced. As a consequence, the higher  $\phi$ P appears as class 8 object marker *bi-* to the left of the verb. The so-created complex including the object marker and the verb then moves on to adjoin to the final suffix *-ile* under AspP.

The derivation of a Type 1 relative sentence, as in (420a) in which no lexical subjects figure but instead a co-referential subject marker appears on the verb proceeds in a similar manner, with the only difference that instead of a lexical subject, the subject marker is merged into the canonical subject position, *spec,vP*. The lexical subject is merged directly as a null topic into a position in the left periphery, from where the subject marker will receive its referential value. The direct object marker in verb-complement position bears an interpretable [TOP]-feature (besides a set of interpretable  $\phi$ -features) that will ensure that it is this element that will agree with  $v$  (assuming Full Match) and subsequently incorporate, and not the indirect object, which is actually closer to  $v$ .

The derivation of an object relative clause involving an applicativised ditransitive verb, as in (422a) in which the indirect object is relativised rather than the direct object is straightforward, with the only difference that the applicative  $\phi$ P in *spec,AppIP* will count as closest goal for the unvalued  $\phi$ -features of  $v$  (and, importantly, not the direct object or the subject), since it enters the derivation equipped with an additional [TOP]-feature, required to satisfy the Full Match condition. Consider the representation in (422b).

- (422) a. *mtu wa-a-m-h-el-a baana bilewa \*(,) Iddi*  
 1man 1REL-N.PST-1OM-give-APPL-FV 2child 8food 1Iddi  
 “the man to whom the children have given food on his behalf, Iddi (that is)”



established, two copies of the  $\phi$ P exist. They form a chain, of which only the highest member will be pronounced, ergo the object marker to the left of the verb.

However, I have also shown that an approach to feature valuation according to which the  $\phi$ -features of a probe simply probe downward until they find a goal with a matching set of  $\phi$ -features is not sufficient to adequately describe the object-marking facts in Bembe. I have thus proposed that object markers enter the derivation with an interpretable [TOP]-feature. This is in line with their topic interpretation, and serves to ensure that it is the  $\phi$ P that agrees with and incorporates into  $v$ , satisfying the corresponding unvalued feature  $v$ . The incorporated  $\phi$ P receives its referential index from a dislocated (and possibly null) topic in the C-domain. This is sufficient to correctly derive the word order and object-marking facts in transitive, ditransitives, applicatives, applicativised ditransitive and relative constructions. Note that the question whether (abstract) case plays a role in the Agree relation between  $v$  and the incorporated  $\phi$ P will be deliberately left open for the time being, and since nothing in the present analysis hinge on this question, I will postpone discussion of the issue until Chapter 4.

### **3.6 Summary and conclusions**

The aim of Chapter 3 was to introduce the properties of object marking in Bembe, decide on the question whether it should be treated as an agreement or rather a pronominal phenomenon, and to present a syntactic analysis which is able to capture the object-marking data, in accordance with recent minimalist assumptions.

The chapter began by introducing the huge variation that exists with respect to object marking within the Bantu languages and the theoretical treatment it has received in the literature. Whereas most Bantuists favour a pronominal analysis of object markers for the majority of Bantu languages, this has been called into question by some who convincingly showed that this may be not be necessarily true with respect to all members of this language family (see Riedel 2009).

In order to determine whether this may also the case for object markers in Bembe, I applied a number of diagnostics standardly employed in the literature, the results of which lead me to conclude that they must be pronominal rather than agreement morphemes. In particular, the fact that there exist (i) an obligatory intonation break and (ii) interpretational differences in the presence of object markers, besides (iii) the co-occurrence restrictions between object marking and indefinite, focused, relativised, passivised elements and negative-polarity items, *and* (iv) the ungrammaticality of

certain orderings of object-marked objects and other elements, points to the conclusion that object-marked objects are obligatorily dislocated. It follows that object markers, if they are in complementary distribution with lexical objects, must be pronominal in the sense of being theta-role bearing arguments.

I then proceeded to resolve the resulting question as to what kind of pronouns they could be, and concluded, in line with the diagnostics provided by C&S (1999), that they cannot be strong pronouns due to their inability (a) to be coordinated with other DPs, (b) to appear in the canonical object position and (c) to be clefted. Further evidence for this comes from their semantics, as they cannot be used ostensively either. Their phonological necessity to attach to a host, ultimately, leads me to analyse them as clitics, rather than weak pronouns. In particular, I follow C&S in analysing them as defective pronouns, i.e.  $\phi$ Ps.

I argued for a representation of the verb in Bembe following Julien (2002), according to which the verb in Bantu only moves to a position below T (specified here as AspP). As opposed to the more traditional view of V-to-T movement of the verb, Julien proposes that the parts of the verb are formed differently: suffixes are the result of (iterating) head-movement, while prefixes are attached to the verb by a morpho-phonological operation. This has the advantage of being able to account in a principled way for why some heads attach as suffixes while others appear as prefixes.

Subsequently, I reviewed and discussed a number of different proposals concerning clitic placement and tested them against the Bembe object-marking data. As a result, I concluded that an analysis à la Roberts (2010), according to which object markers are theta-role bearing, defective pronouns – i.e.  $\phi$ Ps, which are externally merged in verb-complement position and the syntactic structure of which enables them to incorporate into their probe. Their lack of a D-layer as well as semantic content (a root) is what allows them to incorporate into the verb, as opposed to strong pronouns and lexical objects which cannot incorporate because their feature-sets are not proper subsets of that of the probe (either because the probe lacks the corresponding unvalued features of some of the features of lexical DPs, such as the value of root (cf. Holmberg 2010), or because it lacks an EPP feature (cf. Roberts 2010a,b)).

However, I have also shown that a standard approach to Agree (Chomsky 2000, 2001), as adopted by Roberts (2010a,b), according to which probing is downward is insufficient to adequately describe the object-marking facts in Bembe, since the principle Closest Goal alone does not guarantee that the correct goal will be chosen for the Agree relationship with  $v$ . I have thus proposed that Agree with  $v$  requires Full

Match, and that object markers enter the derivation equipped with an interpretable [TOP]-feature, required to value the unvalued counterpart on  $\nu$ . This is in line with their topic interpretation, and serves to ensure that it is the  $\phi$ P that agrees with and incorporates into  $\nu$ , satisfying the corresponding unvalued feature on  $\nu$ . The incorporated  $\phi$ P is provided with a referential index by a necessarily definite (and possibly null) topic in the C-domain. This is sufficient to correctly derive the word order and object-marking facts in transitive, ditransitives, applicatives, applicativised ditransitive, and subject and object relative constructions. The fact that incorporation of defective pronouns into  $\nu$  can be equally well explained by assuming that it is triggered by the need to value a feature suggests that despite all differences that exist between affixes and clitics, pronominal and grammatical agreement are actually two sides of the same coin (cf. Givón 1976, Roberts 2010a,b).

## CHAPTER 4 – SUBJECT MARKING IN BEMBE

### 4.1 Introduction

In the previous chapter, I have presented evidence for the view that object markers in Bembe are pronominal clitics, i.e.  $\phi$ Ps, rather than grammatical agreement morphemes. Largely following ideas proposed by Roberts (2010a,b), I claim that they incorporate into the verb under  $v$  from an argument position. Since they are analysed as theta-role bearing arguments, it follows that they obligatorily force co-referential objects into an extraposed position, which accounts for the distribution of object markers with respect to overt object DPs and the attested word-order facts. In this chapter, I will turn the focus of attention to the phenomenon of subject markers with the aim of finding an answer to the question as to which analysis is most appropriate to formally capture the Bembe subject-marking and word-order facts.

Similarly to object markers, subject markers in Bembe cross-reference subject arguments with which they agree in class on the verb. *Prima facie* they bear a striking resemblance to object markers, particularly in their ability to license non-overt arguments, which could lead one to treat them as being pronominal elements too, along the lines of the analysis proposed for object markers in the preceding chapter. Consider (423), which shows that subject DPs can be omitted under the condition that the referent is retrievable from either the anterior discourse or the extra-linguistic context.

- (423) a. *Mlome*    *a-koch-ile*    *bilewa*.  
1husband    1SM-buy-PST    8food  
“The husband bought (some) food.”
- b. *A-koch-ile*    *bilewa*.  
1SM-buy-PST    8food  
“He bought (some) food.”

However, treating subject and object markers on the basis of examples such as in (423) on par would mean to miss one oft-noted major difference between them: while in most Bantu languages object markers can be omitted (under the respective language-specific conditions), subject markers are always obligatory, irrespective of the overtness of the co-referential subject DP. Consider the examples in (424), which show that Bembe is no

exception to this (at least in simple declarative clauses). We note then, at least in this respect, one difference in the behaviour of subject markers from that of object markers.

- (424) a. *Iddi a-koch-ile bilewa.*  
 1Iddi 1SM-buy-PST 8food  
 ‘‘Iddi bought (some) food.’’
- b. \**Iddi koch-ile bilewa.*  
 1Iddi buy-PST 8food  
 (Int. ‘‘Iddi bought (some) food.’’)
- c. *Ba-a-chw-a m-numba.*  
 2SM-N.PST-come-FV 18-9house  
 ‘‘They have come into the house.’’
- d. \**A-chw-a m-numba.*  
 N.PST-come-FV 18-9house  
 (Int. ‘‘They have come into the house.’’)

Although all Bantu languages show the ability to drop subject DPs (under the language-specific identity conditions), the co-occurrence restrictions (or absence of them) between subject marking and subject DPs makes them a particularly worthwhile topic of study. In fact, much of the literature on subject marking in Bantu centers on the question whether it should be analysed as pronominal or grammatical agreement, or even as being ambiguous between the two.

The remainder of the chapter begins by reviewing the recently revived theoretical debate surrounding its grammatical nature in Bantu and other null subject languages, before I embark on an analysis of the categorial status of subject markers in Bembe. In section 4.2, I answer the question whether subject markers should be treated as agreement, pronouns, or as being ambiguous between the two. I dismiss the view according to which subject markers are ambiguous between being agreement morphology and pronouns (section 4.2.1). Instead, I present evidence which shows that preverbal subjects show topic-like properties, which suggests that they are always in a dislocated (A’) position, which in turn suggests that subject markers are pronominal rather than grammatical agreement morphology (section 4.2.2).

As regards the structural make-up of the Bembe clause, I subsequently show in section 4.3.1 how a traditional movement analysis, according to which subject markers



are pronominal syntactic objects, copes with the presented Bembe facts. More recent grammatical-agreement analyses, in contrast, attempt to explain the perceived topic status of preverbal subjects in Bantu by alluding to the presence of null subjects that ultimately control agreement, like Baker (2003, 2008) (section 4.3.2) and Carstens (2005) (section 4.3.3). Such analyses stress that Bantu languages defy Chomsky's (2000, 2001) approach to probe-goal feature valuation in that agreement seems to require a spec-head relation between probes and goals, and thus movement. As a result, most analyses tend to modify the probe-goal system to accommodate the Bantu facts. In section 4.3.4, I show that an account as presented by Henderson (2006, 2011a) who introduces the most far-reaching alteration to the operation Agree, is able to explain a variety of subject-marking patterns and word orders across Bantu languages, in particular the variation in availability and subject agreement within single Bantu languages with regard to operator constructions (REL/TOP V S). However, the predictions Henderson's analysis makes are not entirely borne out for Bembe, and the theory fails to predict attested word orders and subject-marking patterns.

In section 4.3.5, I claim that the reason for this lies in the fact that Henderson's and other accounts are flawed in their initial assumption to treat subject markers as the spell-out of an Agree relation between T and a null subject *pro*. Rather, they should be analysed as the spell-out between T and pronominal  $\phi$ Ps. Following Roberts' (2010a,b) treatment of Romance object clitics and in analogy to Bembe object markers, I claim that subject markers are deficient clitic pronouns ( $\phi$ Ps), i.e. theta-role bearing arguments of the verb, which are base-generated in  $\nu$ P and which, due to their defective nature, must incorporate into the head position in T, whenever their  $\phi$ -features are a subset of the  $\phi$ -features of the probe. This precludes the need for an active spec,TP position in Bembe. Incorporation of a  $\phi$ P is taken to be a corollary of the operation Agree. Despite being theta-role bearing arguments,  $\phi$ Ps are non-referential, and thus in need of a referential value, which is provided by a dislocated (and possibly null) A(boutness)-topic DP (Frascarelli 2007, Holmberg 2010), which additionally explains the A'-properties of preverbal subjects. A further advantage is that such a proposal relinquishes the need for drastic changes to the probe-goal approach to Agree, instead advocating downward probing and no spec-head requirement for agreement, in line with Chomsky (2000, 2001). With these assumptions in place, such a proposal is able to account for a number of agreement and word order facts, which the discussed theories struggle to explain. As a result, the different word orders and subject-marking patterns between Bembe and other Bantu languages can be reduced to the different syntactic status of the

subject markers, either being the spell-out of Agree between *pro* and T or that of a  $\phi$ P and T (or rather, in the case of expletive VS constructions, the spell-out of agreement relation between a  $\phi$ P<sub>Expl</sub> and T).

Section 4.4 is devoted to Case and the question of how Case-feature valuation is resolved in the proposed analysis. Bantu languages do not show morphological case, and I present empirical evidence from a number of Bantu languages (cf. Diercks 2012), which even suggests that abstract Case is altogether absent in the Bantu language family. Evidence in the form of licensed DPs in non-licensed positions, licensed DPs in non-Case-marked positions, and the ability of DPs to move out of positions in which they have had their Case-feature valued lead me to conclude that the same is true for Bembe. Ultimately, this paints a picture according to which *u*Case-features cannot play a part in the feature-valuation process. Section 4.5 concludes the chapter by summarising the findings.

#### **4.2 The categorial status of subject markers**

The phenomenon of subject marking in Bantu has so far defied a unified theoretical analysis. Opinions about its exact grammatical status range from one end of the spectrum to the other, and over time and depending on the language, it has been analysed as either anaphoric agreement (Givón 1976), grammatical agreement or as being ambiguous between the two. While the latter analysis is most prominently advanced in B&M's (1987) seminal work on the syntax of Chichewa, there is a strong tradition of analysing verbal inflections in null subject languages as actual arguments of the verb (Borer 1984; Jaeggli 1982, 1986; Suñer 1988; A&A 1998; Barbosa 1995). A number of researchers working within a Generativist tradition, in turn, treat subject marking as an instance of grammatical agreement (Baker 2003, 2008; Carstens 2005; Henderson 2006, 2011a; Kinyalolo 1991 among others). I will present each of the views and discuss them in turn, before reviewing the arguments in favour of a pronominal analysis of Bembe subject markers (section 4.2.2). Subsequently, I apply the diagnostics given by Cardinaletti & Starke (1999) in order to determine which kind of pronoun we are dealing with in Bembe (section 4.2.3).

#### 4.2.1 Subject markers as ambiguous elements

In their seminal work about topics, pronouns and agreement in Chicheŵa, carried out within the framework of Lexical Functional Grammar (LFG), B&M (1987) reach the conclusion that the subject marker is either an agreement marker signaling the Agree relationship an overt subject and the verb have entered, or acts as an incorporated pronoun in the absence of an overt subject which refers to a topic NP (whose interpretation is either accessible through discourse or contextual cues) (B&M 1987: 755).

In the framework of LFG for a sentence to be well formed certain conditions have to be met. One such well-formedness condition is the so-called Uniqueness Condition, according to which no two arguments in a clause can bear the same function. Thus, when a sentence contains an overt subject, the subject marker cannot also act as argument of the verb and is thus to be regarded as an agreement marker instead of an incorporated pronoun. Consider (425).

- (425) *Njuchi zi-ná-lúma-a alenje.* (Chicheŵa; B&M 2001: 150)  
Bees SM-PST-bite-FV hunters  
“The bees bit the hunters.”

The overt subject and the subject marker in (425) are sufficiently ‘local’ to enter an agreement relation. It follows that the subject marker *zi-* cannot function as incorporated pronoun as we would then have two subjects in one clause. Instead, it must be seen as an agreement marker.

Another well-formedness condition is the so-called Completeness Condition, according to which every argument that is lexically required needs to be present in the surface structure. This means that in null subject constructions, some other overt element must take over the argument function. This is arguably fulfilled by the subject marker, acting as incorporated pronoun. Note that the Completeness Condition is the reason why LFG differs so drastically from Generative theories by not permitting the existence of any null subjects such as *pro*. In the light of this, consider (426) in which a subject DP has been extracted and arguably occupies a dislocated position in the left periphery.

(426) *Mkángó uwu, alenje a-ku-gáníza kutí ú-ma-fúná*  
 Lion(3) this hunters SM-pres-think that SM(3)-HAB-want  
*ku-gúmúla nyumbá yá mfúmu.*  
 INF-pull.down house of chief

“This lion, the hunters think that it wants to pull down the chief’s house.”

(B&M 1987: 756)

B&M contend that the subject marker *ú-* in (426) cannot function as agreement marker since the dislocated subject *mkángó* and the subject marker in the subordinate sentence are not in the same clause. Thus, in order to satisfy the Completeness Condition, the subject marker needs to assume the function of an incorporated pronoun acting as subject argument of the verb in the subordinate sentence. The simplified structural representations of a transitive sentence (a) with and (b) without overt subject are given in (427).

(427) a. [TP Subject [T' SM+v [vP Subject [v' v...]]]]  
 b. [TP SM [T' v [vP SM [v' v...]]]]

Despite the fact that B&M’s theory is able to account for the data in Chicheŵa, there exist a range of problems with their account. First, B&M claim that subject markers are obligatory in a finite sentence while incorporated object markers are optional (B&M 1987: 743). Thus, as we have seen for the example in (426), B&M accordingly contend that the subject marker *u-* is to be treated as incorporated pronoun acting as the subject of the subordinate clause. However, if this were the case, one is inclined to ask where the obligatory subject marker is in the subordinate clause. Following B&M’s line of argumentation, one would expect two forms of the subject marker *u-* to appear in the subordinate clause, one acting as the subject of the clause and the other as the obligatory agreement marker. This however is not the case as the examples in (428) & (429) show.

(428) \**Mkángó uwu, alenje a-ku-gáníza kutí ú ú-ma-fúná*  
 Lion(3) this hunters SM-pres-think that it SM(3)-HAB-want  
*ku-gúmúla nyumbá yá mfúmu.*  
 INF-pull.down house of chief

“This lion, the hunters think that it wants to pull down the chief’s house.”

- (429) *Mkángó* *uwu*, *alenje* *a-ku-gáníza* *kutí* *ú-ma-fúná*  
 Lion this hunters SM-pres-think that it-HAB-want  
*ku-gúmúla nyumbá yá mfúmu.*  
 INF-pull.down house of chief  
 “This lion, the hunters think that it wants to pull down the chief’s house.”  
 (B&M 1987: 756)

B&M try to strengthen their argument with the following example of a subject marker functioning as incorporated pronoun. Consider (430).

- (430) *Fisi a-na-gúlá chipéwá ku San Franciscó dzulo. Madzũlo*  
 Hyena SM-past-buy hat(7) in S.F yesterday evening  
*a-na-pítá ku San Jose kuméné á-ná-ká-chí-gulítsá kw’á mlóndá wá*  
 he-past-go to S.J. where he-past-go-it-sell to guard of.  
*á méya.*  
 hon. Mayor  
 “The hyena bought a hat in San Francisco yesterday. In the evening he went to San Jose, where he went to sell it to the honourable mayor’s guard.”  
 (Chicheŵa; B&M 1989: 748)

According to B&M, the subject marker on the verb *a-na-pítá* in the second sentence cannot act as subject agreement because it is separated from the subject *Fisi* by a sentence boundary, and thus a local agreement relation with the subject cannot be established. Due to this locality violation, the subject marker is taken to function as an incorporated pronoun, which assumes the subject role in the second sentence. This argument however is at most valid for a theory situated within the framework of LFG. In a Chomskyan analysis, in turn, no locality violation is incurred. Instead, the subject marker in question is assumed to be the spell-out of an Agree relation between T and a null subject *pro* in preverbal subject position, the identification of which is not hindered by the clause boundary.

Moreover, B&M’s distinct treatment of subject markers versus object markers is inconsistent. As we have seen, when an object appears in conjunction with an object marker, the former is regarded as an adjunct while the latter functions as an optional incorporated pronoun. The question that arises subsequently is why subjects do not

receive the same treatment and are not analysed as having adjunct status in conjunction with subject markers.

Finally, not only from a minimalist viewpoint but in any formal account in which a one-to-one relationship between function and structure is postulated, B&M's claim of structural ambiguity with respect to subject markers is clearly undesirable.

Given the arguments I have discussed in this section, I oppose B&M's analysis of subject markers as being ambiguous between agreement morphology and pronouns and choose to not pursue it any further. Instead, it is much more desirable to have a consistent analysis according to which subject markers in Bembe are either pronominal elements or agreement morphology. Therefore, the question at hand is to determine whether, and, if so, to what extent this is possible, which I will deal with in the next section.

#### **4.2.2 Agreement morphology or pronouns?**

I now turn to the question whether subject markers in Bembe should be analysed as pronominal elements or rather as agreement morphology. Deciding on the question is not a straightforward task and, as we shall see, involves a number of diagnostics. We have already noted that if subject markers were pronominal elements, subject-marked subjects should not be able to co-occur in the inflectional domain but should, instead, be forced into a dislocated position in order to avoid a theta-criterion violation. In such cases of apparent doubling, we expect subject-marked subject DPs to show properties associated with dislocated elements (e.g. topics). In turn, if subject markers were agreement morphology, doubling of the subject DPs should be permitted, and preverbal subjects should occupy the canonical subject position spec,TP.<sup>37</sup> An agreement analysis thus makes no predictions as to the information-structural status of subject-marked subject DPs, i.e. they do not have to necessarily be topics. Since there is no intonation break or any other phonological cue in Bembe that indicates dislocation of the subject from the rest of the clause, the burden of proof lies with those claiming that subject marking is pronominal. I will present evidence from distributional and interpretational facts that strongly suggest that subject DPs are obligatorily forced into a dislocated position in Bembe due to the pronominal status of Bembe subject markers. In particular, evidence stemming from (i) the distribution of subject markers with negation markers,

---

<sup>37</sup> I employ the terms 'subject-marked' and 'doubling' to refer to subject DPs that appear simultaneously with the corresponding subject marker on the verb.

(ii) the obligatory wide-scope readings of preverbal subject DPs, (iii) the non-availability of preverbal foci or negative polarity items, and (iv) the complementary distribution of subject markers and subject DPs in object relative clauses suggest that subject DPs are always in dislocated position whenever they are subject-marked. This in turn is suggestive of the pronominal status of the verb-marking morphology in Bembe.

*Negation precedes subject marker*

One argument for the A'-status of preverbal subject DPs comes from their distribution with negation markers. Preverbal subject DPs in Bembe cannot be in the prototypical surface position because negation always follows the subject DP but precedes the subject marker. If one assumes that the subject marker moves to T below NegP but the subject DP is above NegP, the subject cannot be in the same maximal projection as the subject marker, i.e. spec, TP, as this would incorrectly predict the unattested order NEG > subject.<sup>38</sup>

- (431) *Maria ta-a-komb-ile Petelo.*  
 1Mary NEG-1SM-hit-PST 1Peter  
 “Mary did not hit Peter.”

*Wide-scope reading of preverbal quantified subjects*

As regards the scope properties of preverbal subjects, a pronominal approach predicts that preverbal quantified subjects should not show any reconstruction effects and therefore always have wide scope since they never occupy spec,TP. In the Greek example (432a), *some student* necessarily has wide scope over the universal quantifier, i.e. there is one certain student who filed every article. The sentence cannot have a reading where *every article* has wide scope over *some student* such that there are different students who filed every article.

- (432) a. *Kapios fititis stihiothetise kathe arthro* [some>every, \*every>some]  
 some student filed every article

---

38 See Laka (1994), Zanuttini (1997) and Giorgi & Pianesi (1997) for arguments that a NegP above TP is a parametric option alongside of the more familiar order TP > NegP. One could alternatively assume that TP > NegP in Bembe, in which case movement of the negative head in front of the verbal complex would have to be made responsible for deriving the correct morpheme order negation > tense, as in (i).

(i) [TP Neg T [NegP t<sub>Neg</sub> [vP...V...]]]

- b. *Stihiothetise kapios fititis kathe arthro* [some>every, every>some]  
 filed some student every article  
 “Some student filed every article.” (A&A 1998: 505)

Since Bembe does not allow VSO sentences, I cannot replicate the Greek examples in (432). Yet, the same effect should be visible in contexts in which the subject needs to be interpreted as being in the narrow scope of the quantified object to prevent a non-sensical reading, which would arise if it had a wide scope reading. The prediction is that if the subject DP cannot appear in a preverbal position, this is evidence that it is unable to do so because it cannot reconstruct into an A-position. The examples in (433) illustrate that this is indeed the case, as in order to achieve a felicitous reading, i.e. for the subject DP to be in narrow scope, it has to appear in a postverbal position.

- (433) a. \**Mtu a-le mo-himan-a m-numba tfose.* [wide scope =  
 1man 1SM-COP PROG-sit-FV 18LOC-9house 9all non-sensical]  
 (Int. “A (certain) man is sitting in every house.”)
- b. *ʔwa-le mo-himan-a mtu m-numba tfose.*  
 15EXPL-COP PROG-sit-FV 1man 18LOC-9house 9all  
 “There is a man (or the other) sitting in every house.” [narrow scope]

It seems reasonable then to conclude that preverbal subjects in Bembe can reconstruct into the canonical subject position because they are in fact outside of the inflectional domain to begin with. In order to strengthen this observation, language consultants were asked to read what is perceived to be an ambiguous quantifier sentence (434) and were presented with a set of continuation sentences, each of which expresses a logical continuation of the discourse. They were then asked to judge the appropriateness of the continuation sentences. The first continuation sentence implies a wide-scope reading on the subject, whereas in the second sentence it is in the narrow scope of the object. If Bembe preverbal subjects were to occupy an A-position, both sentences should be rated as meaningful continuation. If they were to occupy a clitic left-dislocated A'-position, we should expect only sentence (435a) to be judged as meaningful continuation of the discourse. As the examples below illustrate, the prediction is borne out since (435b) is not felicitous under a narrow-scope reading of the subject.



(434) *O-no mwana a-som-ine bitabo byose.*  
 1some 1child 1SM-read-PST 8book 8all  
 “Some child read every book.”

(435) a. *A-lo-soakelw-a manga.* [some > every]  
 1SM-PST-like-FV much  
 “He liked them a lot.”

b. *#Ba-lo-soakelw-a manga.* [\*every > some]  
 2SM-PST-like-FV much  
 “They liked them a lot.”

*No indefinite preverbal subjects*

Following Cinque (1990), dislocated elements are necessarily definite or specific from which follows that non-specific indefinites should be disallowed from appearing in preverbal position. If preverbal subjects were to occupy a dislocated position, they should have a strong specific reading, while postverbal subjects should have a (non-specific) existential reading since they occur within the *vP*, the domain said to encode existentiality (cf. Diesing 1992). In fact, it is not possible for (436a) to receive an existential reading (= some unspecified child), while (436b) can only mean that a non-specific child fell down.

(436) a. *Mwana a-a-kwel-a.*  
 1child 1SM-N.PST-fall-FV  
 (Lit. “Child has fallen.”)  
 “A (certain) child has fallen down.”

b. *ɔwa-a-kwel-a mwana.*  
 15EXPL-N.PST-fall-FV 1child  
 (Lit. “Has fallen child.”)  
 “(Some) child has fallen down.”

*Ban on Wh-phrases in preverbal position*

If preverbal subjects in Bembe were in a dislocated position, we would not expect non-referential Wh-phrases to appear in preverbal position either. For a range of Bantu languages it has indeed been shown that this is the case (cf. Baker 2003 for Kinande; Bokamba 1976 for Dzamba; Demuth & Johnson 1989 for Setawana; Kimenyi 1980;

Maxwell 1981 for Kinyarwanda; Ndayiragije 1999 for Kirundi; Muriungi 2005 for Kitharaka; Sabel & Zeller 2006 for Zulu; Zerbian 2006 for Northern Sotho). In such cases subject Wh-question words require extraction, typically in the form of a cleft construction. Schneider-Zioga (2007) shows that this is the case in Kinande and notes that a special agreement marker *-u-* must appear in such circumstances. She contends that these so-called “anti-agreement markers” signal extraction of Wh-phrases to a position above spec,TP.<sup>39</sup>

Interestingly, for Bembe this is not different. Two strategies for forming a Wh-question are permitted: a structure comparable to an English it-cleft, illustrated in (437a-b), and in-situ Wh-questions (438) with intransitive verbs. Note that answers to a Wh-subject question must either be clefted or show a postverbal subject, suggesting that the immediate preverbal position cannot be a focus position.<sup>40</sup> Consider the examples in (437) & (438).

(437) a. Q: *A-le beni i-wa-a-komb-á Petelo?*

1SM-COP 1who FOC-1REL-N.PST-hit-FV 1Peter

(Lit. “It is WHO that has hit Peter?”)

“WHO has hit Peter?”

A: *A-le Mary i-wa-a-komb-á Petelo.*

1SM-COP 1Mary FOC-1REL-N.PST-hit-FV 1Peter.

(Lit. “It is MARY who has hit Peter.”)

“MARY has hit Peter.

b. Q: *A-le beni i-wa-a-kol-á bilewa?*

1SM-COP 1who FOC-REL-N.PST-buy-FV 8food

(Lit. “It is WHO that has bought food?”)

“WHO has bought food?”

39 Schneider-Zioga (2000:1) not only takes this to be evidence for a ban of referential expressions to appear in spec,TP but for her, “[t]he answer must go beyond the idea that anti-agreement is simply a morphological reflection of the subject occupying the specifier of CP.” She goes further by proposing that “preverbal subjects are located in a topic phrase very high in an enriched CP field”, as illustrated in (i).

i. [topic phrase *Subject-NP* [focus phrase [wh-phrase [ ... ]]]

40 There is of course the possibility of answering a subject question with a fragment answer consisting only of the focused element (e.g. “*Who was it?*” - “*Mary.*”). I will however not discuss this possibility.

A: *A-le Iddi i-wa-a-kol-á bilewa.*  
 1SM-COP 1Iddi FOC-1REL-N.PST-buy-FV 8food.  
 (Lit. “It is IDDI who has bought (some) food”)  
 “IDDI has bought food.”

(438) Q: *ɔwa-a-chw-a beni?*  
 15EXPL-N.PST-come-FV 1who  
 (Lit. “Has come WHO?”)  
 “WHO has come?”

A: *ɔwa-a-chw-a baana.*  
 15EXPL-N.PST-come-FV 2child  
 (Lit. “Have come the children.”)  
 “THE CHILDREN have come.”

*No preverbal negative polarity items*

Another piece of evidence in favour of the topic-like quality of preverbal subjects comes from the constraint on preverbal (non-referential) negative quantifiers. To express them, either an existential construction with the postverbal DP *mtu* ‘person’ (with the meaning of ‘anybody/nobody’), as in (439a), or a relative construction without an overt subject has to be employed, as in (439b). In any case, a subject DP cannot receive the negative reading whenever it is in preverbal position (439c).

(439) a. *Ta-ɔwa-chu-le mtu.*  
 NEG-15EXPL-come-PST 1person  
 (Lit. “There did not come (any) person.”)  
 “Nobody came.”

b. *Ta-le i-wa-chu-le.*  
 NEG-COP.PST FOC-1REL-come-PST  
 (Lit.: ‘There was not (anybody) who came.’)  
 “Nobody came.”

c. \**Mtu ta-a-chu-le.*  
 1person NEG-1SM-come-PST  
 (Int. “Nobody came.”)

*Complementary distribution of SMs and subject DPs*

The pronominal status of subject markers is also supported by the complementary distribution displayed with subject DPs, that is, with respect to the inflectional domain. This is particularly evident in object relative clauses, of which Bembe has two types: Type 1 object relatives in which agreement on the verb is with the relativised object and a subject that cannot appear overtly, and Type 2 object relatives in which agreement on the verb is only with the relativised object DP while any overt subject DPs must appear in a postverbal position. If the subject marker was merely the spell-out of a grammatical agreement relation, nothing should prohibit it from appearing with a postverbal subject DP. The data, however, suggest otherwise, as shown in (440).

- (440) a. *bilewa bi-ba-a-kol-á* (\**batu*)  
8food 8REL-2SM-N.PST-buy-FV 2person  
“the food that they have bought”
- b. *bilewa bi-(\*ba)-a-kol-á* *batu*.  
8food 8REL-2SM-N.PST-buy-FV 2person  
“the food that (some) people have bought”

Having shown that preverbal subjects in Bembe show the above-listed properties vis-à-vis sentential distribution and interpretation which are strongly associated with topics, I conclude that they must be elements occupying an A'-position. In particular, their obligatory wide-scope reading and complementary distribution with subject markers (in the inflectional domain) is indicative of their dislocated position, which in turn implies that Bembe subject marking is a purely pronominal phenomenon. The list in (441) summarises the properties of preverbal subjects in Bembe.

- (441) Properties of Bembe preverbal subjects
- Precede negation markers
  - Show obligatory wide-scope readings
  - Must not be foci or negative polarity items
  - Are in complementary distribution with subject markers

### 4.2.3 The categorial status of the subject marker

In this section, I will Apply C&S's (1999) diagnostics (see also Chapter 3) to determine the categorial status of Bembe subject markers. They could be strong pronouns, weak pronouns or clitics. As far as their syntactic characteristics are concerned, the three pronouns differ in five respects: (a) syntactic status (XPs or X°), (b) theta-position, (c) coordination, (d) clefting, and, ultimately, (e) modification. Semantically, weak pronouns and clitics differ from strong pronouns in that the former cannot be used ostensively since they need an antecedent in the discourse. As regards phonology, weak pronouns and clitics differ from strong pronouns in that they can form a phonological unit with a lexical item while the latter cannot. In what follows, I will apply the diagnostics presented by C&S to Bembe in order to identify the syntactic nature of the subject marker.

To begin with, subject markers cannot appear in subject positions, i.e. immediately preceding or following the verb, which however is possible for full DPs and strong pronouns. Consider (442).

- (442) a. *Iddi a-lo-mon-a Ali.*  
1Iddi 1SM-PST-see-FV 1Ali  
“Iddi saw Ali.”
- b. *Ɛwe a-lo-kol-a bilewa.*  
1he 1SM-PST-buy-FV 8food  
“He bought (some) food.”
- c. *\*a a-lo-mon-a ngyo?a.*  
1SM 1SM-PST-see-FV 9snake  
(Int. “He saw a snake.”)

Secondly, subject markers cannot be coordinated with other DPs, as in (443).

- (443) a. *Iddi na Ɛwe ba-lo-som-a bitabo.*  
1Iddi and 1he 2SM-PST-read-FV 8book  
“Iddi and him read (some) books.”

- b. \**Iddi na a ba-lo-som-a bitabo.*  
 1Iddi and 1SM 2SM-PST-read-FV 8book  
 (Int. “Iddi and he read (some) books.”)

In contrast to strong pronouns, subject markers cannot be clefted either. Consider (444).

- (444) a. *A-le εwe i-wa-som-iné etabo.*  
 1SM-COP 1he FOC-1REL-read-PST 7book  
 “It is him who read a book.”
- b. \**A-le a i-wa-som-iné etabo.*  
 SM-COP 1SM FOC-1REL-read-PST 7book  
 (“It is him who read a book.”)

The last syntactic diagnostic concerns modification. While strong pronouns can be modified, weak pronouns and clitics cannot. This is also true for Bembe, as (445) illustrates.

- (445) *Bale εbo/(\*ba) inose i-ba-a-yak-á ngyo?a.*  
 2SM-COP they/2SM only FOC-2REL-N.PST-kill-FV 9snake  
 (Lit. “It is only them who has killed a snake.”)  
 “Only they killed the snake.”

The data so far suggest that subject markers in Bembe behave more like defective pronouns than strong ones. This should also be visible with respect to their semantics. C&S contend that strong pronouns differ from weak pronouns and clitics in that the former do not need to refer to an antecedent in the discourse, while the latter always have to. It follows that strong pronouns should be able to be used ostensively, i.e. deictically, while clitics should not. As (446) illustrates, the same holds for Bembe. Subject markers cannot be used ostensively because they are non-referential and need an antecedent in the discourse.

- (446) a. *εwe a-a-kol-a bitabo.*  
 1he 1SM-N.PST-buy-FV 8book  
 “He has bought (some) books.” (pointing at someone)



Given the importance of the different agreement and word-order patterns of Bembe relative clauses in the quest for the structural representation of subject markers, I will begin this section by outlining the analysis of relative clauses have received in Generative Grammar before presenting how the aforementioned analyses cope with the Bembe facts.

#### 4.3.1 Relative clauses – Theoretical background

As we have seen before, Bembe shows three types of relative clauses (RCs), one subject relative clause, and interestingly, two types of object relative clauses. In subject relatives, there is agreement between the relativised subject and the verb in the form of a relative marker, as shown in (447a). In Type 1 object relative clauses, agreement on the verb is with the object DP in the form of a relative marker and with a covert subject in the form of a subject marker, as shown in (447b). Alternatively, in Type 2 relatives, an overt subject DP surfaces, which must appear postverbally and does not control verb agreement. Instead, the verb only displays agreement with the object DP, in the form of a relative marker, as shown in (447c). The information-structural content of the two types of object relative clause differs; In Type 1 relatives, the subject must be a topic, while it is focused/non-referential in Type 2 relatives.

- (447) a. *mtu wa-a-kol-a bilewa* (Subject relative clause)  
 1person 1REL-N.PST-buy-FV 8food  
 “the/a person that has bought food”
- b. *bilewa bi-a-a-kol-a* (Type 1 object relative clause)  
 8food 1REL-1SM-N.PST-buy-FV  
 “the food that he/she has bought”
- c. *bilewa bi-a-kol-a mtu* (Type 2 object relative clause)  
 8food 1REL-N.PST-buy-FV 1person  
 “the food that SOMEBODY has bought”

The examples in (448) show that preposition stranding is prohibited in Bembe.



- (448) a. *Ta-ba-iky-e*      *o-le*      *mwele* *o-na-bémb-ile*      *n(a)*  
 NEG-2SM-know-FV 17SM-be 3knife 3REL-1SG-cut-PST with  
*eho nyama.*  
 3which 9meat  
 (Lit. “They do not know where is the knife I cut the meat with which.”)  
 “They do not know where the knife with which I cut the meat is.”
- b. \**Ta-ba-iky-e*      *o-le*      *mwele* *eho*      *o-na-bémb-ile*      *n(a)*  
 NEG-2SM-know-FV 17SM-be 3knife 3which 3REL-1SG-cut-PST with  
*nyama.*  
 9meat  
 (Lit. “They do not know where is the knife which I cut with meat.”)  
 “They do not know where the knife with which I cut meat is.”

Object marking of relativised objects is completely ungrammatical, as shown in (449). Coupled with the fact that Bembe object markers have been identified as pronominal clitics, the ungrammaticality of the examples in (449) is suggestive of the fact that relativised objects originate within the relative clause.

- (449) a. \**Baana ba-ba-mon-ilé*      *Iddi* *ba-a-b-ile*      *babembe.*  
 2child 2REL-2OM-see-PST 1Iddi 2SM-COP-PST 2Bembe  
 (Int.: “The children which Iddi saw were Bembe.”)
- b. \**bilewa* *bya-bi-koch-ilé*      *baana*  
 8food 8REL-8OM-buy-PST 2child  
 “the food that (some) children bought”

The theoretical discussion of relative clauses (RCs) evolves around two issues: (a) the relation between the relative clause and the modified head of the relative, and (b) the relation of this relative head to the relativisation site. Given the fact the relative head seems to play a role in the relative-clause-internal syntax and semantics although forming part of the matrix clause, the questions arise whether a relative clause is a complement or an adjunct of the DP that contains it, and whether the relativized element is base-generated in a position external to the clause or originates inside of it.

For a long time, the standard analysis of relative clauses has been one according to which a relative clause is a CP which right-adjoins to an NP, which is itself merged outside of the relative clause and selected by an external determiner (cf. Chomsky

1977), as illustrated in (450).

(450) [DP the [NP [NP book [CP which [TP John bought ~~which~~ ]]]]]

Note that there is no direct relation between the relative head and the relativisation site in (450), since it is claimed that no movement of the relative head out of the relative clause occurs. Within the relative clause, a relative pronoun or null operator is merged in verb-complement position, which subsequently A'-moves into spec,CP. The relative head and the relative pronoun/operator are linked by predication, which results in the fact that the determiner which selects the NP is structurally higher than the relative clause CP. This enables the analysis to capture the fact that the external determiner scopes over both the relative head NP and the relative clause, as the following example and its semantic interpretation in (451) illustrate (cf. Alexiadou et al. 2000: 5)

(451) a. every girl that Mary saw  
 b.  $\forall x$  [girl (x)  $\wedge$  Mary saw (x)]

The adjunction analysis sketched above remained unchallenged until Kayne's (1994) Antisymmetry Hypothesis, which presupposes a strict mapping between hierarchical relations of asymmetric c-command between any two non-terminal nodes in a tree and a linear ordering of the terminal symbols that these non-terminals dominate. Among other things, it presupposes binary branching and that right-adjunction is an illicit operation, which makes the Head-External analysis of relatives untenable.<sup>41</sup> Kayne (1994) proposes what is referred to as the Head-Raising Analysis for relative clauses, the structure of which (452) is claimed to be the only one in conformity with the Linear Correspondence Axiom (LCA).<sup>42</sup>

(452) [DP the [CP **book**<sub>j</sub> [CP [**which book**]<sub>i</sub> [IP John likes [**which book**]<sub>i</sub> ]]]]

41 Naturally, a number of empirical problems have been identified in connection with the adjunction analysis over the years, a discussion of which, however, would lead too far astray.

42 The Linear Correspondence Axiom claims that hierarchical structure fully determines linear order:

- (i) For any two non-terminals X, Y, if X asymmetrically c-commands Y, then all terminals x dominated by X precede all terminals y dominated by Y.



relative clauses despite the fact that coordination and extra-position contexts, with both that- and Wh-relatives, illustrate that the head NP cannot be within the relative CP.

- (455) a. the picture [which Bill liked] and [which Mary hated]  
 b. the picture [that Bill liked] and [that Mary hated]  
 c. I met a girl   <sub>1</sub> yesterday [who I used to date in high school]<sub>1</sub>  
 d. I met a girl   <sub>1</sub> yesterday [that I used to date in high school]<sub>1</sub>

(Salzmann 2006: 7)

Although Bembe does not have that- or Wh-pronouns (or any overt relative pronouns for that matter), the data can be replicated for Bembe, as in (456), and serve to illustrate that the NP cannot be in the relative CP in Bembe either.

- (456) a. *picha* [ya-a-ond-á Bill] na [ya-a-somb-á Mary]  
 9picture 9REL-N.PST-like-FV 1Bill and 9REL-N.PST-hate-FV 1Mary  
 “The picture which Bill liked and Mary hated.”  
 b. *Na-sangan-ine na msea elya ekolo o-na-a-ond-a.*  
 1SG-meet-PST with 3girl 7DEM.dist 7night 3REL-1SG-PRES-like-FV  
 “I met a girl yesterday which I like.”

The aforementioned points of criticism led Bianchi (1999, 2000) to modify Kayne’s proposal. In an attempt to unify the analyses of Wh-relatives, that- and zero-relatives, she argues against movement of the relative head NP to the specifier of the relative pronoun in Wh-relatives. Instead, she assumes a Split-CP projection à la Rizzi (1997), and claims that the relative DP is first moved to a specifier position of a lower Top(ic) P(hrase) within the CP, from where it sub-extracts and moves to Spec, CP (Bianchi 1999: 190–197, 2000: 130).<sup>44</sup>

---

44 Bianchi’s reformulation of Kayne’s (1994) proposal is not free of obstacles either, of which I mention just one here, as any more would lead the discussion too far afield. One question that arises with Bianchi’s modification is what motivates raising of the relative head NP and, concretely, the last step to the specifier position of the relative determiner, as indicated in bold letters in (i). See Bhatt (2002) for further discussion.

(i) a. [DP [D the [CP [DP [NP story]<sub>j</sub>] [D which t<sub>j</sub>] ]]<sub>i</sub>] [C you read t<sub>i</sub>] ]]  
 b. [DP [D the [CP [PP [NP house]<sub>j</sub>] [P **in** [DP which t<sub>j</sub>] ]]<sub>i</sub>] [C you are living t<sub>i</sub>] ]]

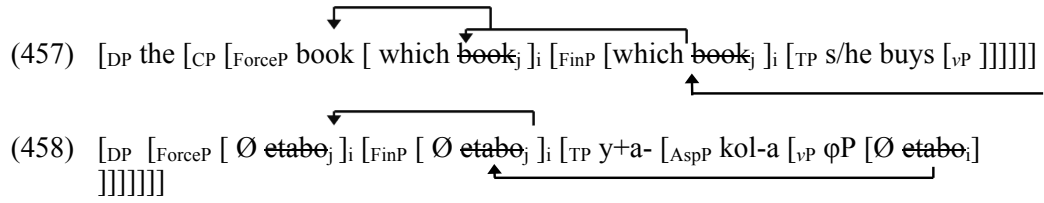

One of the reasons for which I adopt a Head-Raising analysis is its ability to account for reconstruction effects in Bembe. Reconstruction is possible with Condition A and B, as illustrated in (459a-b), and Condition C, as shown in (459c).

- (459) a. *picha ya ewe imwene ya-a-kol-á John*  
 9picture 9of 1he self 9REL-N.PST-buy-FV 1John  
 “the picture of himself<sub>i</sub> that John<sub>i</sub> has bought”
- b. *Ndoko yake<sub>i</sub> ya-a-ond-á mtu<sub>i</sub> wose ta-a-ikyo-b-a*  
 9relative 9POSS.3SG 9REL-PRES-like-FV 1person 1all NEG-1SM-HAB-COP-FV  
 (Lit. “relative his (who) likes every person is not”)  
 “The relative of his<sub>i</sub> that every person<sub>i/j</sub> likes does not exist.”
- c. *E-le picha ya John i-y-a-a-kol-á?*  
 9SM-COP 9picture 9of 1John FOC-9REL-1SM-N.PST-buy-FV  
 (Lit. “It is the picture of John that (he) has bought?”)  
 “Is it the picture of John<sub>i</sub> that (he<sub>\*i/j</sub>) has bought?”

#### 4.3.2 Bresnan & Mchombo (1987)

One example of a traditional movement analysis has already been introduced in the preceding chapter in the form of B&M’s (1987) account of object marking. Although I have decided to not follow B&M in their treatment of subject markers as being functionally ambiguous between agreement markers and incorporated pronouns, I will nonetheless illustrate how such an account tries to derive the attested word orders and verb-marking patterns in Bembe.

Just as with their analysis of object markers in Chapter 3, B&M’s analysis of subject marking is not immediately transferrable to Bembe. The reason for this is that their analysis is not rooted in Chomskyan Generative Grammar but rather in Lexical-Functional Grammar, and B&M thus make no comments about a possible structural representation. However, it seems reasonable to assume that in cases of an overt subject

DP, the subject marker is taken to be the spell-out of an agreement relation between that subject DP and T, and in the case of a non-overt subject DP, subject markers are some kind of syntactic object with argument status. B&M do not offer an explicit discussion of the issue but I assume that they regard subject markers as inflectional prefixes, which combine with the verb in the morphological component of the Grammar rather than in the syntactic one. In case subject markers are seen as having argument status, they would be base-generated in spec, $\nu$ P and subsequently move to the traditional subject position, spec,TP. However, to keep in line with the findings made about the A'-properties of preverbal subjects in Bembe, I am rather inclined to treat subject DPs as occupying spec,CP (either overtly or covertly), while the subject marker actually acts as grammatical subject in spec,TP. This would eliminate the earlier-criticised mismatch between form and function of subject markers, as they would be analysed as pronominal syntactic object in both cases, irrespective of the presence of a subject DP. The analysis of a declarative clause (with overt or covert subject, as indicated by the brackets) could then look like (460).

- (460) a. (Baana) *ba-a-kol-a* *bilewa*.  
 2child 2SM-N.PST-buy-FV 8food  
 “(The children)/they have bought (some) food.”

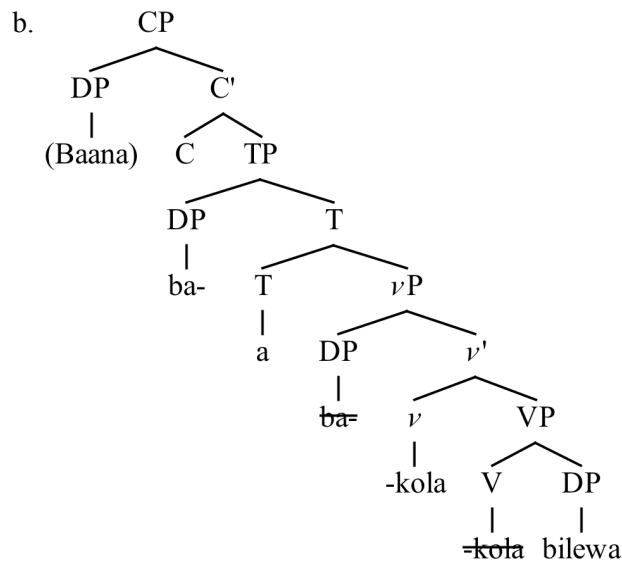

The subject marker *ba-* is base-generated in spec, $\nu$ P from where it raises to spec,TP, presumably in satisfaction of an EPP requirement on T. Preverbal subject DPs appear either overtly or covertly in spec,CP, which captures the fact that they show strict A'-characteristics in Bembe. Moreover, since it is assumed that a theta-role is distributed to

subject markers, and they hence must be generated in spec, $\nu$ P, the complementary distribution between them and overt subject DPs in object relative construction follows naturally, since there is no position for the latter. Consider the example in (461).

- (461) a. *bilewa bi-ba-a-kol-á* (\**baana*)  
 8food 8REL-2SM-N.PST-buy-FV 2child  
 “the food that they/\*some children have bought”

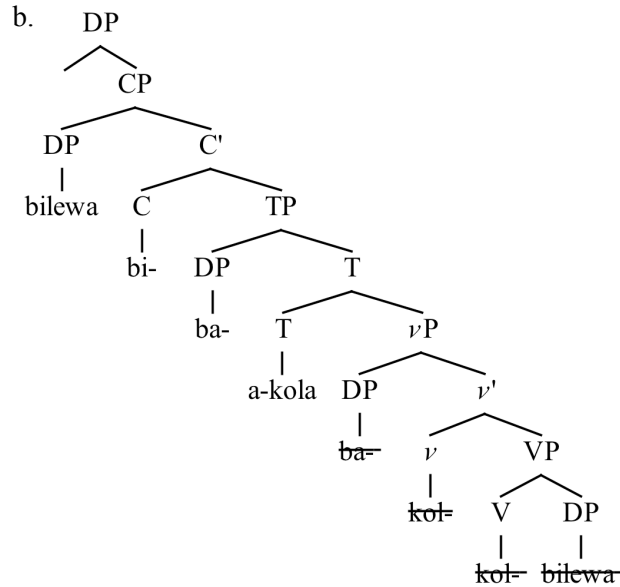

However, a pronominal movement analysis that treats the subject marker as syntactic element in its own right, (merged in argument position and capable of absorbing a theta-role) rather than the spell-out of an agreement relation between a probe T and a goal becomes problematic in connection with Bembe Type 2 object relative clauses. Although it correctly predicts that there cannot be a subject marker in the presence of an overt subject DP in such structures, it fails to explain why the overt subject DP stays low in object relative constructions, especially in the light of the fact that subject markers always raise into spec,TP, presumably in an attempt to satisfy the EPP requirement.

- (462) a. *bilewa bi-(\*ba)-a-kol-á* \*(*baana*) [Type 2 object relative]  
 8food 8REL-2SM-N.PST-buy-FV 2child  
 “the food that the children have bought”

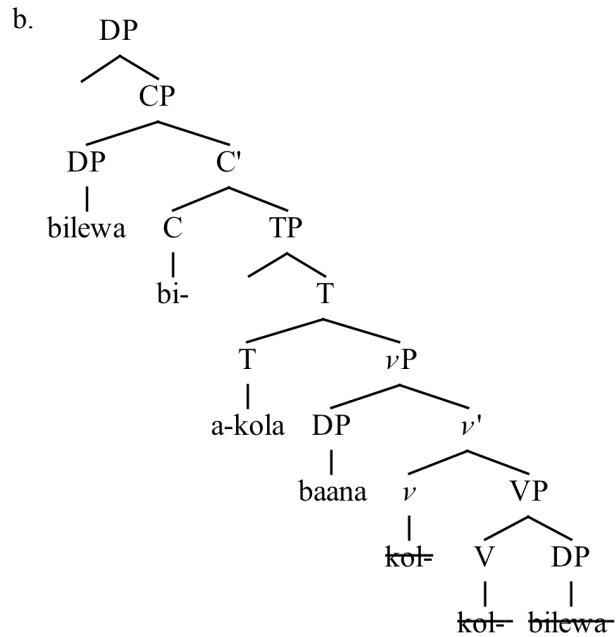

We have seen that a pronominal analysis according to which the subject marker starts out as pronominal argument in spec,vP, receives the agent theta-role and combines with the verb under T faces problems when applied to Bembe. The analysis does not answer the question as to why overt subject DPs in Type 2 object relatives do not raise into spec,TP, especially in the light of the fact that subject markers obligatorily raise to that position.

#### 4.3.3 Baker (2003, 2008)

We have seen that a movement analysis according to which the subject marker starts out as pronoun in spec,vP faces problems when presented with the Bembe facts. One of the motivating factors to assume a movement analysis of subject markers are the A'-properties of preverbal subjects. However, as mentioned earlier, the fact that preverbal subjects in Bembe seem to be generated in an A'-position does not a priori rule out an agreement analysis. As opposed to analyses within an LFG tradition, a Chomskyan approach makes an analysis available, according to which subject markers are treated as inflectional markers licensing a null subject *pro* in subject position in order to try to account for the A'-properties of preverbal subjects, as presented in Baker (2003, 2008) and Carstens (2005), whose approaches I will discuss next.

Baker (2003) who argues on the basis of Kinande, which he refers to as being polysynthetic languages, that Bantu languages in more general always have agreement



with a null argument and display dislocation of agreeing phrases. Since dislocation is generally only possible with definite and/or specific elements (cf. Rizzi 1986), the agreeing phrase must be in a specifier position higher than the usual one, i.e. somewhere above spec,TP. Recall the earlier-mentioned example (repeated here as (463)), which shows that agreement with the verb in the form of a class 8 object marker is possible because the topicalised object is in a left-dislocated position above spec,TP.

- (463) *Bilewa, ba-a-bi-kol-a.*  
 8food 2SM-N.PST-8OM-buy-FV  
 “The food, they have bought it.”

Baker (2003: 109) claims that “a verb X agrees with an NP Y if and only if Y is in a dislocated, adjunct position.” Since all agreeing phrases should be dislocated, his claim naturally extends to subject NPs, which results in the following representation (464):

- (464) [TP' NP<sub>i</sub> [TP *pro*<sub>i</sub> T <Agr<sub>i</sub>>+Verb... [<sub>VP</sub> t<sub>i</sub>... ]]]

Most importantly, Baker’s view of the operation Agree deviates fundamentally from the standard view of Agree (Chomsky 2000, 2001). According to Chomsky, a probe with uninterpretable and unvalued features probes the c-commanded structure for a suitable goal. Upon finding it, it will enter an Agree relation with the goal, in the course of which the interpretable features of the goal will value those unvalued ones on the probe. If the probe also bears an EPP-feature, the agreeing goal will be additionally raised into the specifier of the probing head. It follows that every instance of Move is dependent on a previously established Agree relation. The opposite, however, is not the case, i.e. an Agree relation is not dependent on the operation Move.

To account for the different agreement patterns between Indo-European (i.e. Romance) and Bantu languages, Baker proposes that Agree be linked to two macro-parameters, the Directionality Parameter and the Case Parameter. The directionality parameter determines whether agreement is with an element in the c-commanded domain, or whether it is with a c-commanding element, i.e. one that is structurally higher than the probing head. Baker (2008) claims that for Bantu the parameter is set in

such a way that probes always probe upwards.<sup>45</sup> Baker is not alone in criticising Chomsky’s (2000, 2001) dissociation of the operations Agree and Move as being too restrictive for Bantu, especially in the light of the oft-iterated claim that agreement in Bantu necessitates a spec-head relationship between the probe and the goal (cf. Kinyalolo 1991; Demuth and Harford 1999; Koopman 2000; Carstens 2005; Henderson 2006, 2011a among others).

In addition to the directionality of agreement, languages are parametrised as to whether the probe values the unvalued Case features of a goal. Based on the absence of morphological case marking in Kinande, and Bantu in more general, Baker claims that Bantu lacks structural Case. Since no Case is assigned to the element in spec,TP, no fully specified NP can occupy this position, as it would otherwise be left with an unvalued Case feature at LF, resulting in a crash of the derivation. However, some element has to occur in spec,TP to satisfy the alleged EPP-feature, and Baker claims that *pro* is a prime candidate since it does not need Case but is able to satisfy the EPP.

The motivation for a strong connection between agreement and movement in Bantu comes primarily from inversion constructions such as Default Agreement and Locative Inversions. Many Bantu languages allow for structures in which the logical subject appears postverbally and agreement on the verb is with a null expletive or with a preverbal locative phrase rather than with logical subject, such as in (465) and (466).

(465) *Hó-tswalá lipó:li.* (Sesotho; Demuth 1990: 239)  
 17SM-give.birth 10goat  
 “There are goats giving birth.”

(466) a. *Mu-ki-liḽa mu-tumbuk-í li-holo.* (Ndendeule; Ngonyani 1996: 210)  
 18-7well 18SM-fall.into-PERF 5tortoise  
 “Into the well has fallen a tortoise.”

---

45 Diercks (2012) and Henderson (2006a, 2011a) make similar claims. Van der Wal (2009) presents serious counter-examples to Baker’s attempt of parameterizing Bantu languages by reporting on agreeing inversion-constructions in Makhuwa.

(i) *waa-nú-mwááryá mweéri.* (van der Wal 2009: 199)  
 3.PAST-PERS-shine 3.moon  
 ‘the moon was shining’

- b. *Mu-zízo nyumbá mu-á-nyám-é bána wálúbí.*  
 18-10that 10house 18SM-FUT-sleep-FV 2child one.day.period  
 “There will sleep children in those houses tomorrow.

(Kilega; Kinyalolo 1991)

Baker adopts V-to-T movement of the verb in Bantu, an assumption that I have earlier dismissed in favour of Julien’s (2002) V-to-AspP analysis (see Chapter 3). I still subscribe to Julien’s approach, and nothing in Baker’s analysis hinges on this. Consider the example of a Bembe declarative clause in (467).

- (467) a. *Baana ba-a-kol-a bilewa.*  
 2child 2SM-N.PST-buy-FV 8food  
 “The children have bought (some) food.”

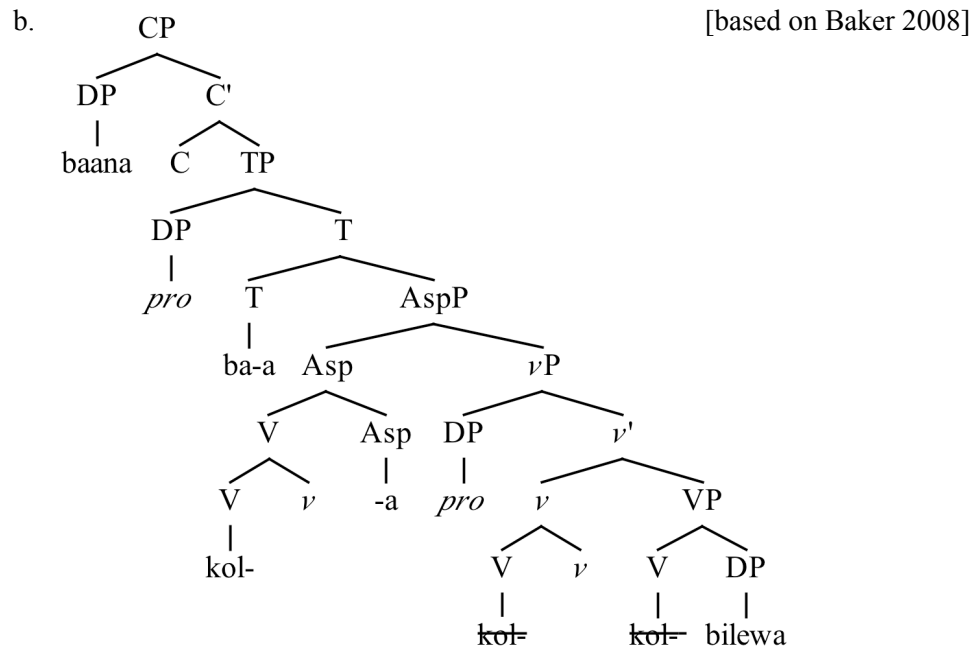

In (467b) *pro* is merged in spec,*vP* and raises to spec,*TP* in an attempt to satisfy the EPP-requirement, which Baker assumes to be universal. Given that the directionality parameter for Bantu is set to upwards probing, T probes the c-commanding structure for a goal and finds it in the  $\phi$ -features of *pro* in spec,*TP*. An Agree relation is established between the two, ultimately spelled out as class 2 subject marker *ba-*. In case a subject DP figures in the numeration, it will be merged as a dislocated adjunct to *TP* (here assumed to be spec,*CP*), which is in line with the topic interpretation preverbal subject DPs receive in Bembe.

We have already seen that Bembe also features inversion structures such as Default Agreement Inversions and Locative Inversion, repeated in (468). Default Agreement Inversion is restricted to unaccusative and copular verbs, while both VSO and VOS orders are ungrammatical.

- (468) a. *ʔwa-a-chw-a*                    *baana*.  
 15EXPL-N.PST-come-FV 2child  
 “There have come/arrived (some) children.”
- b. \**ʔwa-a-yak-a*                    *baana ngyoʔa*.  
 15EXPL-N.PST-kill-FV 2child 9snake  
 (Int. “There have killed children snakes.”)
- c. \**ʔwa-a-yak-a*                    *ngyoʔa baana*.  
 15EXPL-N.PST-kill-FV 9snake 2child  
 (Int. “There have killed children snakes.”)

According to Baker’s analysis, such expletive inversions are explained by assuming that the logical subject is merged as a DP complement of an unaccusative verb and moves to spec,VP. However, it stays within the VP, while T agrees with an expletive null subject which has been merged in spec,TP to satisfy the EPP condition. The insertion of an expletive marker is also motivated by considerations with respect to the principle of Economy of Derivation: the operation External Merge is considered less costly in terms of cognitive effort than the operation Move, since the latter consists of the two independent operations Copy and Merge. Consider (469).

- (469) a. *ʔwa-a-chw-a*                    *baana*.  
 15EXPL-N.PST-come-FV 2child  
 “There have come (some) children.”

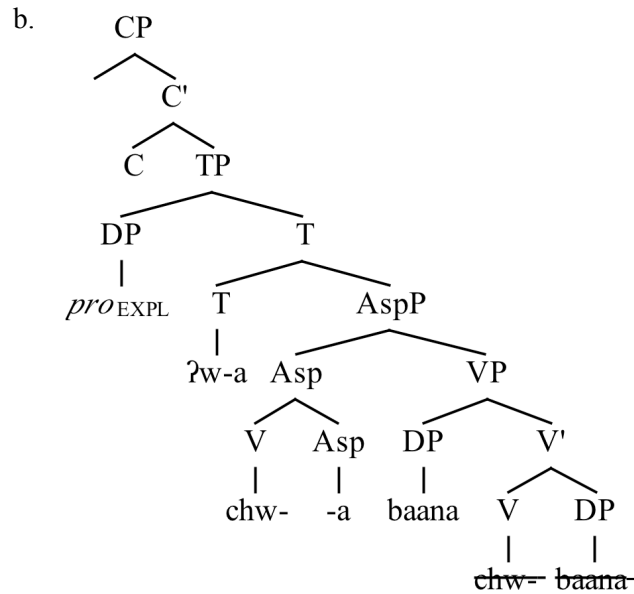

Locative Inversion in Bembe is also only possible with copular verbs and unaccusatives, as shown in (470). Importantly, agreement on the verb is with the preverbal locative and not with the postverbal logical subject, the latter of which receives a narrow information-focus reading as indicated by the use of upper case in the gloss.

- (470) a. *M-lobonga mu-le baana.*  
 18LOC-11church 18SM-COP 2child  
 “There are (some) CHILDREN in the church.”
- b. *M-numba mwa-a-chw-a mboka.*  
 18LOC-9house 18SM-N.PST-come-FV 1neighbour  
 “Into the house has come A NEIGHBOUR.”

Under Baker’s analysis it is assumed that the logical subject stays low within the VP, i.e. in the verb-complement position it has been merged. A null subject *pro* which is co-referential with the locative DP is merged into spec,vP and moves into spec,TP in order to check the EPP-feature. This will automatically trigger locative agreement on the verb, as *pro* will agree with the features on T. The locative DP is merged directly in spec,CP, in line with the topic reading they receive.

- (471) a. *M-lobonga mu-b-ile baana.*  
 18LOC-11church 18SM-COP-PST 2child  
 “There were (some) children in the church.”

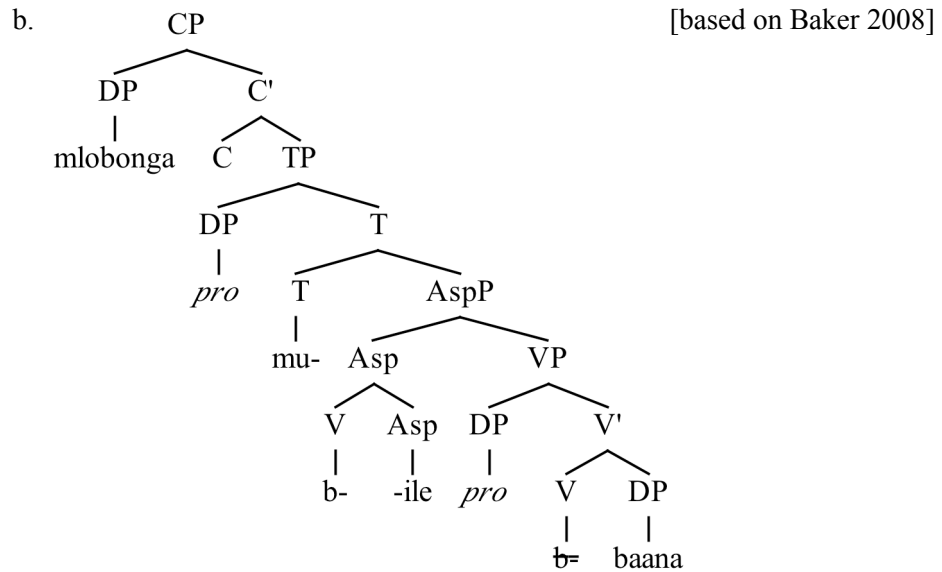

However, there is at least one case of subject-verb inversion that Baker’s analysis struggles to account for, namely that of object relative clauses. We have already seen that Bembe allows two different strategies for the formation of an object relative clause. In what I refer to as Type 1 relatives, the verb agrees with the relativised object and the obligatorily non-overt subject, while in Type 2 relatives the verb agrees with the relativised object only but crucially not with the logical subject DP, which must appear postverbally. Consider the contrast in (472) & (473).

- (472) *bilewa bi-ba-a-kol-á* (Type 1 object relative)  
 8food 8REL-2SM-N.PST-buy-FV  
 “the food that they have bought”

- (473) *bilewa bi-a-kol-á* \*(*baana*) (Type 2 object relative)  
 8food 8REL-N.PST-buy-FV 2child  
 “the food that some children have bought”

For the derivation of Type 1 object relatives (472), the verb supposedly moves to AspP, while a null subject *pro* is merged in spec,vP. Attracted by the need to satisfy the EPP on T, the latter moves to spec,TP and subsequently agrees with T, resulting in the

subject marker *ba-*. Subsequently, the object DP moves to spec,CP, presumably attracted by a [REL]-feature on C. Given the class 8 relative marker, I assume that the interpretable  $\phi$ -features of the relativised object DP value those on C. Consider (474).

- (474) a. *bilewa bi-ba-a-kol-á* (Type 1 object relative)  
 8food 8REL-2SM-N.PST-buy-FV  
 “the food that they have bought”

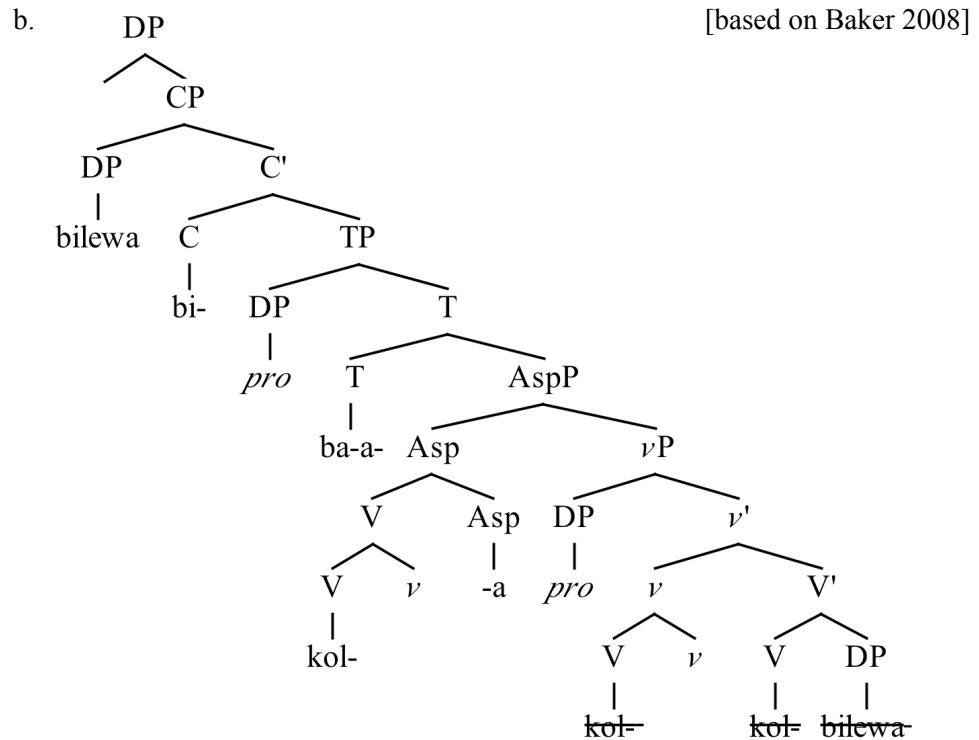

Note that since inflectional morphemes are not prefixed to the verb stem until PF in Julien’s (2002) analysis of verb movement, nothing in this analysis should hinge on the fact that *pro* intervenes between relative, subject and tense marker on the one hand and the verb stem on the other.

Type 2 object relatives (473), in contrast, do not feature subject-verb agreement but only agreement with the relativised object, in the form of a relative marker on the verb. In addition, a subject DP must obligatorily feature in postverbal position. This is suggestive of the subject not being raised to spec,TP but rather remaining low in its merge position. Thus, a possible representation of (475a) could look like (475b).

- (475) a. *bilewa bi-a-kol-á baana* (Type 2 object relative)  
 8food 8REL-N.PST-buy-FV 2child  
 “the food that (some) children have bought”

b. [based on Baker 2008]

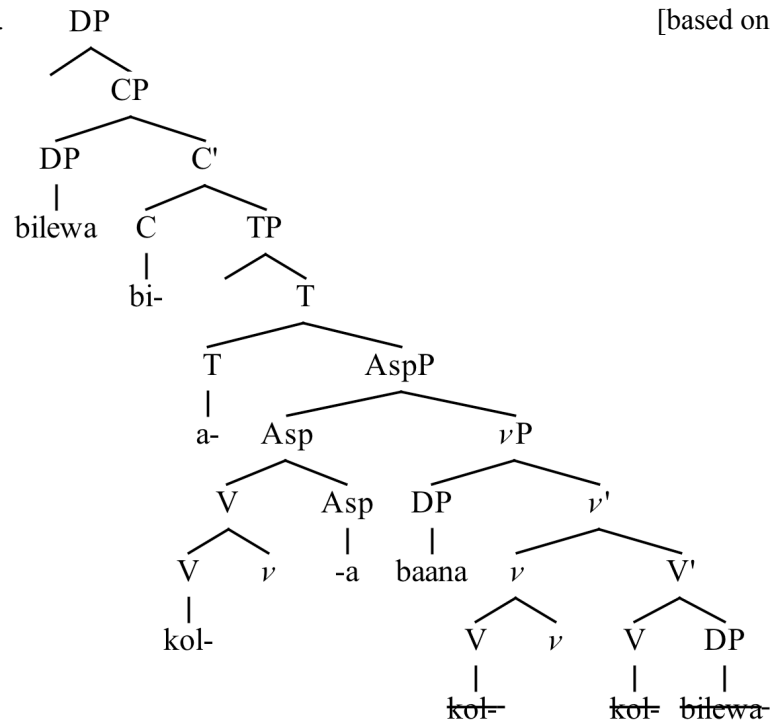

The verb moves to AspP after the subject DP has been merged in spec,vP. If the subject DP had moved into spec,TP, akin to *pro*, we would expect it to have marked the verb. This however is not the case. Under Baker’s view, the ban on subject DPs in spec,TP follows from the fact that the unvalued Case-feature of subject DPs would be left unvalued since Case plays no role for agreement in Bantu. Rather than crossing the verb like *pro*, subject DPs in Type 2 relatives remain in their merge position. This is in line with the fact that postverbal subject DPs (spec,vP/VP) are obligatorily interpreted as being indefinite, whereas a null subject *pro*, which presumably moves to spec,TP in Baker’s account, can only be interpreted as definite. Consider the contrast between (476a-b).

- (476) a. *bilewa bi-ba-a-kol-á* (\**baana*) (Type 1 object relative clause)  
 8food 8REL-2SM-N.PST-buy-FV 2child  
 “the food that (\*some children)/they have bought”



- b. *bilewa* *bi-a-kol-á* *baana* (Type 2 object relative clause)  
 8food 8REL-N.PST-buy-FV 2child  
 “the food that some children/(*\*they*) have bought”

Baker assumes that the EPP is universal. But since the subject DP in Type 2 relatives remains in its base-generated position, one important question that arises is whether anything actually occupies spec,TP or whether it remains empty. If the latter were true, the validity of the claim of a universal EPP would be called seriously into question. Now, the possibility of *pro* occupying spec,TP must be dismissed since there is no subject-verb agreement in Type 2 relatives and external merger of *pro* would violate Condition C of the Binding Theory, according to which R-expressions must be free. Similarly, an expletive null subject is ruled out since we would expect the verb to display the corresponding marker *ɔwa-*. Under Baker’s assumption that the EPP forces agreement with whichever element is raised into the specifier of the agreeing head, the most likely conclusion then seems to be that nothing occupies spec,TP. Under these circumstances, it follows that the EPP cannot possibly be universal, as Baker wants us to believe.

An alternative under which it could be possible to maintain the universality of the EPP and a close connection between movement and agreement in Bantu languages is to assume that, contrary to what the linear order might suggest, the subject does indeed move to spec,TP. The inverted order of subject and verb could then be derived either by postulating VP movement across the subject position (cf. van der Wal 2009), or by spelling out the lower copy of the subject (in case a copy theory of movement is assumed (cf. Chomsky 1995)). I exclude the former analysis for Bembe on the grounds that this would incorrectly predict VOS orders to be grammatical.

In contrast, an analysis in which the lower copy of the subject is spelled out has been claimed to be able to derive inversion structures in Italian (cf. Bošković 2001; Bošković & Nunes 2007; Sheehan 2010). Despite the fact that this (not uncontroversial) assumption derives the correct order of verb and subject, there exist problems with such an approach. Consider (477b), which illustrates the course of the derivation of the Type 2 object relative clause in (477a) at the point at which the subject DP is presumably copied into spec,TP.

- (477) a. *bilewa bi-a-kol-á baana* (Type 2 object relative clause)  
 8food 8REL-N.PST-buy-FV 2child  
 “the food which (some) children have bought”

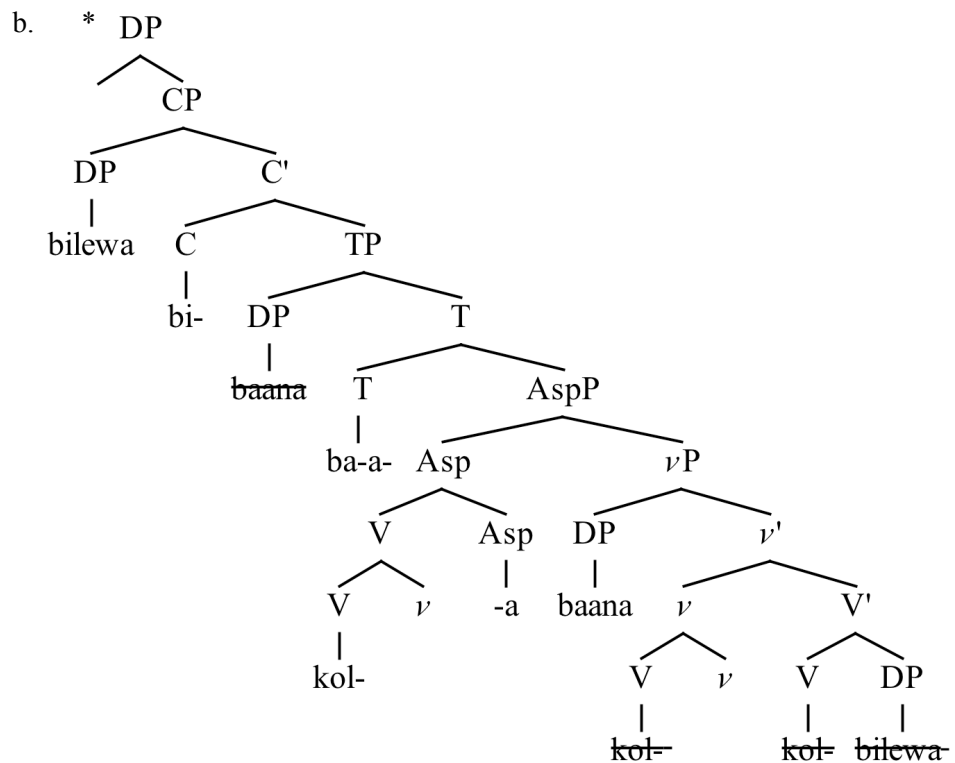

Granted that the higher copy of the subject will not be pronounced at PF, it is reasonable to assume that once it is copied into spec,TP, it will nonetheless enter an Agree relation with T, the result of which will be spelled out as the class 2 subject marker *ba-* at PF. This, however, is contrary to facts, as we have seen that Type 2 relatives do not show subject agreement on the verb.

I conclude then that the ‘low spell-out’-analysis also makes the wrong prediction for Default Agreement Inversions in Bembe. In the light of this, it is unlikely that the EPP is active in Bantu and hence universal, which brings us back to Baker’s inability to explain why in Bembe only *pro* seems to be able to raise into spec,TP while DPs are excluded from appearing in that position.

One could bar subject DPs from raising to spec,TP and salvage the analysis in (477) by entertaining Baker’s hypothesis that in Bembe T simply does not value the *uCase* features of subject DPs. This way we would derive the fact that the only element allowed to occupy spec,TP is referential *pro* since it does not possess a *uCase* feature in need of valuation. This would be a possible explanation as to why presumably preverbal

null subjects can agree with the verb in Type 1 relatives but postverbal subject DPs never do. However, if we accept this as an explanation, we are forced to conclude that for those Bantu languages unlike Bembe, in which preverbal subject DPs in relative clauses *are* allowed (e.g. Zulu & Lingala), T *must* in fact be able to check the *uCase* feature of subject DPs in spec,TP, as we would otherwise predict non-raising of subjects, against the facts illustrated in (478).

- (478) a. *Inja e-mfana wa-yi-thenga in-hle.* (Zulu; Poulos 1982)  
 9dog 9CA-1boy 1SA-9OA-buy 9SA-good  
 “The dog which the boy bought is good.”
- b. *munkanda mi-ye baasi ba-tind-áká awa*  
 5letter 5CA-REL 2women 2AGR-send-PST here  
 “the letter that the women sent here” (Lingala; Bokamba 1981: 39)

This consequence is clearly undesirable from Baker’s point of view, as it would mean that at least in the Bantu languages Zulu and Lingala Case actually *does* play a role in the operation Agree, which would seriously undermine Baker’s initial intention to capture the differences between agreement and word order in Bantu and Romance by postulating that Agree is linked to a universal EPP in Bantu while being linked to Case in Romance. If T were able to check *uCase* features of the subject, Zulu and Lingala would have to be grouped with Romance languages, meaning that Baker’s macro-parameters would have to be ultimately dismissed on the grounds of being too permissive.

What is more, since Minimalist Case Theory adopts the view that every argument bears an *uCase* feature, which is required to be valued in the course of the derivation, the inability of T to value the *uCase* features of subject DPs also leaves the question open as to how exactly a subject DP gets its *uCase*-feature valued in case it remains in its postverbal position. Baker (2008) claims that postverbal arguments never bear an augment in Kinande, whereby they escape the need to get their Case feature valued. His argumentation, however, is not immediately transferrable to Bembe, as the language does not feature any augments or pre-prefixes. Given the questions the Bembe data, in particular Type 1 relative clauses, pose to Baker’s (2003, 2008) analysis, and the related ones with respect to the issue of upwards-probing and universal EPP, I turn to Carstens (2005) who takes the word order and agreement facts in Bantu languages as a starting point to present a different approach to Agree.

#### 4.3.4 Carstens (2005)

In a similar fashion to Baker, Carstens (2005) (and Collins 2004) tries to explain the Bantu agreement facts by linking agreement and movement in such a way that EPP-features are treated as sub-features of agreement features (479).

(479) Bantu EPP:  $\varphi$ -features have EPP features in Bantu.

Carstens' assumption differs from Baker's in that a spec-head relationship between a probe and a goal in Bantu is the result of Agree, rather than its trigger. They share the common assumption that Case should be dissociated from agreement and that this should result in a close relationship between agreement and movement in Bantu. Carstens, however, differs from Baker's view in that she argues that C and T each bear a set of  $\varphi$ -features, instead of only one on T. Consider (480b), which illustrates what her analysis applied to the Bembe simple declarative clause in (480a) would look like.

(480) a. *Baana ba-a-kol-a bilewa.*  
 2child 2SM-N.PST-buy-FV 8food  
 "The children have bought (some) food."

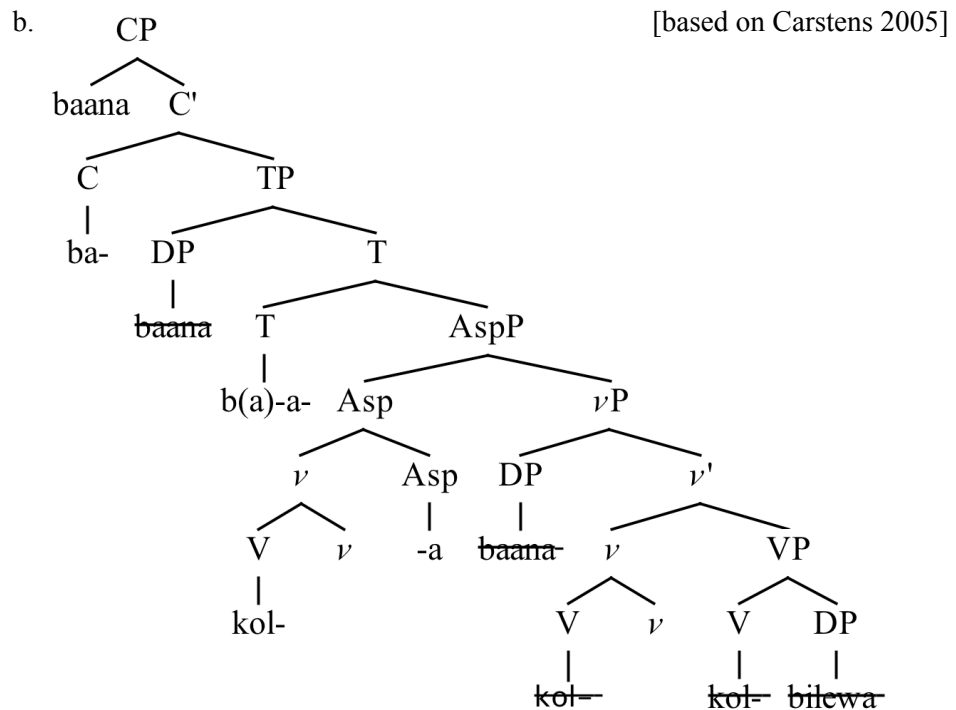

According to Carstens, an extracted argument has to pass through spec,TP to reach spec,CP because after having been attracted to spec,TP by the EPP and  $\phi$ -features on T, it will be the closest goal for the probe on C and subsequently agree with it. That only one of the two agreement relations is spelled out is owed to what Carstens (2005: 253) refers to as ‘Kinyalolo’s constraint’ ((481); Kinyalolo 1991), according to which of two identical sets of  $\phi$ -features that are adjacent, only one will be spelled out. This correctly explains the word order and agreement facts for simple declaratives in Bembe.

(481) *Kinyalolo’s Constraint*

In an adjoined structure, AGR on a lower head is inert iff its features are predictable from AGR on a higher head.

But how does this analysis fare with the variation presented by Bembe object relative clauses, which has proven to pose the biggest problem to Baker’s analysis? The derivation of Type 2 relatives seems straightforward. Consider the example in (482).

- (482) a. *bilewa bi-a-kol-á baana* [Type 2 object relative]  
 8food 8REL-N.PST-buy-FV 2child  
 “the food that (some) children have bought”

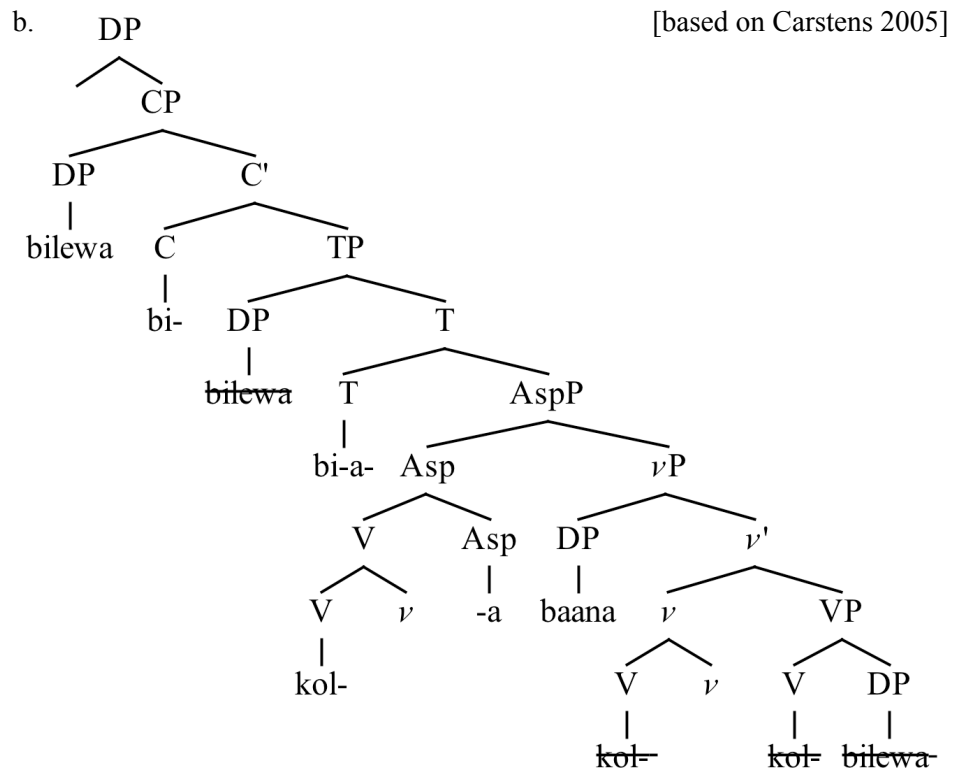

The probe on T establishes an agreement relation with the object rather than the subject. Since agreement is a sub-feature of the EPP, the object will raise to spec,TP to satisfy the EPP and value the  $\phi$ -features on T. In that position, it will subsequently count as closest goal for the probe on C and value its  $\phi$ -features. Subsequent movement of the object DP to spec,CP is also motivated by a [REL]-feature on C. Under the assumption that Kinyalolo's constraint also holds in Bembe, i.e. only one of two morphemes with identical sets of features will be spelled out, the analysis correctly derives Type 2 relatives in Bembe.

One immediate question that arises is why the probe on T can choose the object over the logical subject for its Agree relation despite the fact that the latter is closer to T. Carstens does not comment on this issue, and the [REL]-feature on C cannot possibly be responsible either, since C has not yet been merged when the object DP agrees with the probe on T. Thus movement of the object DP to spec,TP would only take place in anticipation of its subsequent movement to spec,CP. Needless to say that such anticipatory movements are undesirable in a theory where each movement operation is supposedly triggered by the need to value some feature that has already been introduced into the structure.

The derivation of Type 1 relatives is also less than optimal under Carstens' approach. Since an extracted argument has to pass always through the spec,TP position (in order to value the set of  $\phi$ -features on T), the prediction is that cases in which agreement on C is different from the one on T should be impossible. This is because, as we have seen, what occupies spec,TP and agrees with T, will automatically count as closest goal for the probe on C and be forced to agree with it subsequently. Notwithstanding, what we find in Type 1 relatives is exactly this, relativised objects *and* null subjects simultaneously controlling verb agreement. Consider (483).

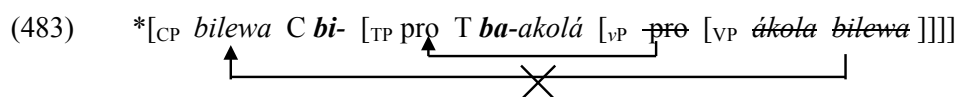

Since subject agreement appears on the verb, one is forced to assume that *pro* agrees with T at some point and moves from spec,vP to spec,TP, thereby also satisfying the EPP on T. However, the object cannot move to spec,CP in an attempt to satisfy the [REL]-feature on C since *pro* in spec,TP is closer to the set of  $\phi$ -features on the probe on C than those of the object in merge position. One could make the [REL]-feature on the object DP responsible for allowing it to be selected by the  $\phi$ -features on C as goal over

the subject DP in spec,vP. While this would correctly derive Type 1 object relative clauses, it does not help in correctly deriving Type 2 object relatives under Carsten's analysis. I conclude then that her approach presents problems when applied to the agreement and word order facts in Bembe, since the assumption that any extracted element (be it topicalised or relativised) must pass through spec,TP on its way to spec,CP, excludes cases in which agreement on C is different from that on T. This way, Carstens incorrectly predicts the ungrammaticality of Type 1 relatives in Bembe.

A solution to the shortcomings of both Baker's and Carstens' analyses in giving an explanation as to why in Bembe covert subjects appear preverbally and mark the verb while subject DPs have to stay low, would be to appeal to an optional rather than a constantly active EPP. In case of a non-active EPP, the logical subject stays low and the result is a Type 2 relative clause without subject agreement. This would also explain the low position of the logical subject in Default Agreement Inversion. However, assuming a non-active EPP in Bembe would bring back the problem we discussed in connection with the 'low spell-out'-analysis above (cf. Bošković 2001; Bošković and Nunes 2007), as it would now be impossible to explain the obligatory presence of the default expletive marker in Default Agreement Inversions, the only motivation of which is the need to satisfy an EPP-feature in the first place. Thus, either a motivation for merging an expletive marker different than the EPP has to be found, or its presence in Default Agreement Inversion remains unaccounted for. On the other hand, in structures with an (optionally) active EPP, the logical subject would be attracted to a preverbal position, and thereby agreement with the verb should be allowed. However, while this would correctly derive Type 1 object relatives (under the assumption that a null subject *pro* satisfies the EPP) and SVO orders in declarative sentences, it also incorrectly predicts that preverbal subject DPs (and not only *pro*) in Type 2 object relatives should be grammatical, which is contrary to the Bembe facts. In summary, postulating an optional EPP amounts to saying that the activity/inactivity of the EPP depends on the elements in the numeration: with *pro* as logical subject, the EPP is activated, hence subject-verb agreement; with subject DPs, in turn, the EPP is always inactive. I fail to see how this does anything else than just stating the Bembe agreement facts in different terms without giving a principled formal explanation.

#### 4.3.5 Henderson (2006, 2011a)

We have seen that both Baker and Carstens are forced to resort to either an inactive or at least, optional EPP in Bembe, which proves to be insufficient to account for the agreement and sentential word order patterns in Bembe since the theory over-generates. What is needed instead is a movement trigger that is able to discriminate between subject DPs and null subjects in object relative clauses. Put differently, the question we have to ask is what the difference between *pro* and a subject DP is that allows the former to raise to a preverbal position, yielding Type 1 object relatives, but not the latter? One aspect that we have not yet taken into account is the different information-structural status of these two elements. Consider (484).

- (484) a. *bilewa* *bi-ba-a-kol-á* (*\*baana*) [Type 1 object relative]  
           8food 8REL-2SM-N.PST-buy-FV 2child  
           “the food that (\*some children) / they have bought”
- b. *bilewa* *bi-a-kol-á* *baana* [Type 2 object relative]  
           8food 8REL-N.PST-buy-FV 2child  
           “the food that some children / (\*they) have bought”

It is clear that null subjects in Type 1 relatives can only be interpreted as being discourse-old due to their inherent topical nature.<sup>46</sup> Subject DPs, in turn, can be foci/non-referential as well as topics, depending on their position in the sentence, as we have seen. Since the postverbal position has been identified as being the domain of focus (cf. Chapter 2), we expect that the postverbal position of subject DPs in Type 2 relatives, which implies non-movement, should translate into an indefinite or focused interpretation. In fact, this is the only interpretation they can receive, as the gloss in (485) illustrates.

- (485) *bilewa* *bi-a-kol-á* *baana* [Type 2 object relative]  
           8food 8REL-N.PST-buy-FV 2child  
           “the food that \*they/\*the/some children have bought”

---

<sup>46</sup> See Holmberg (2010: 93) who claims that null existential indefinites may not exist at all (at least in active clauses).



In addition, there is no subject-verb agreement with postverbal subjects in relatives but only with null subjects. The correlation between postverbal subject DPs, lack of verb agreement and focus/indefinite interpretation on the one hand, and preverbal null subjects, agreement and topic interpretation on the other implies that there may in fact be an obligatory movement trigger linked to agreement. This could be claimed to be a movement trigger (EPP) associated with a [TOP]-feature on T, which is responsible for attracting only subjects the referents of which must be known to the discourse, i.e. topics. It is, in a sense, a more specialised version of the EPP. We would then expect that in constructions in which there is no subject marking but postverbal subjects that these are not topics. This is in line with the data in (486), which shows that postverbal subjects are either in narrow focus, such as in an answer to a subject Wh-question, or in wide focus, such as in all-new contexts (indicated by small capitals in the gloss).

(486) a. Q: *ʔwa-a-chw-a* *beni?*

15EXPL-N.PST-come-FV 1who

(Lit. “Has come who?”)

“WHO has come?”

A: *ʔwa-a-chw-a* *tata.*

15EXPL-N.PST-come-FV 1father

(Lit. “Has come my father.”)

“MY FATHER has come.”

b. Q: *E-le* *éé?*

7SM-COP 7what

(Lit. “It is what?”)

“WHAT HAPPENED?”

A: *ʔwa-a-chw-a* *tata.*

15EXPL-N.PST-come-FV 1father

(Lit. “Has come my father.”)

“MY FATHER HAS COME.”

Similar ideas have been expressed in Zeller (2008) and Miyagawa (2010). The former proposes that the subject marker in Bantu should be treated as antifocus marker while latter claims that some Bantu languages have a [–FOC] feature. The underlying idea is that Bantu languages are parameterized as to whether agreement is linked to a

discourse feature instead of a more general EPP. A similar idea is found in Henderson (2006b, 2011a), who sets out to resolve the variation in word order and agreement in relative clauses and subject-object reversals in Bantu, which makes it particularly relevant to the current discussion. He shows that Bantu languages differ as to whether it is the extracted element and subject DP that control agreement on the verb, as in (487), or only the extracted element, as in (488).

(487) *Inja e-mfana wa-yi-thenga in –hle.* REL S V  
 9dog 9CA-1boy 1SM-9OM-buy 9SM-good  
 “The dog which the boy bought is good.” (Zulu; Poulos 1982)

(488) a. *Omwana a-tom-aki imukanda.* S V O  
 1child 1SM-send-PERF 5letter  
 “The child sent a letter.” (Dzamba)

b. *Imukanda mu-tom-aki omwana.* TOP V S  
 5letter 5CA-send-PERF 1child  
 “The letter, the child sent it.” (Dzamba)

Henderson (2006b) assumes that Bantu languages with constructions such as in (487) have two sets of  $\phi$ -features (one in C and one in T), while those that allow inversion constructions (either TOP V S and/or REL V S) have only one set of  $\phi$ -features in C (but crucially, not T). In his revised (2011) analysis, Henderson allows for the possibility of having a parametric choice between an active and an inactive spec,TP position and follows Carstens (2005) in assuming that C and T in Bantu each carry a set of  $\phi$ -features. The sets of unvalued  $\phi$ -features on C and T are strong, meaning that they attract their matching goals, which is Henderson’s way of capturing the often-made observation that movement and agreement are tied together in Bantu. However, although the variation in operator constructions suggests that not every Bantu language projects a spec,TP position (strictly speaking, the set of  $\phi$ -features on T cannot attract a DP in these cases, because T will not project a specifier), T can still *agree* with DP goals. This follows because Henderson adopts Chomsky’s (2000, 2001) probe-goal approach to agreement but, crucially, modifies it in the way listed in (489) (from Henderson 2011a: 9).

- (489) a. UNRESTRICTED PROBING: Probes can scan both c-commanded and c-commanding structure for potential goals.
- b. MULTIPLE MATCH: Probing features enter Match relation with every possible goal.
- c. LOCAL AGREE: Only the most local Match relation becomes an Agree relation.
- d. DYNAMIC LOCALITY: The locality of syntactic relations is computed at the end of syntactic derivations (before spell-out).

Henderson’s assumption that probes can probe upwards and downwards comes close to Baker’s very liberal view on probing, which the latter restricts with the Directionality Parameter. Henderson, in turn, restricts his system from over-generating by introducing the condition of LOCAL AGREE, i.e. that a probe will only establish an Agree relation with the most local goal. This does neither exclude Agree with c-commanded goals nor with c-commanding goals. One unfortunate consequence is that in some cases more than one goal may be equally local to a set of  $\phi$ -features. Such cases of what he terms ‘symmetric locality’ cannot be interpreted by the computational system, as a result of which the derivation would crash. In order to prevent this, Henderson allows the computational system to choose any goal over the other. Additionally, Henderson shares with Carstens (2005) the assumption that something like Kinyalolo’s constraint is active in Bantu, the (robust) generalisation according to which only one of two adjacent heads with the same feature content need to be spelled out (cf. (481)).

### *Analysis*

What would such an analysis look like if applied to Bembe? Consider the case of a simple declarative clause in Bembe, for which we assume a specifier of TP to be projected in the structure, in line with assumptions made in Henderson (2011a). Additionally, I follow Julien (2002) in her assumption that the verb moves from V-to-AspP, picking up possible suffixes along the way, while prefixes and verb combine via a morpho-phonological operation.

- (490) a. *Baana ba-a-kol-a bilewa.*  
 2child 2SM-N.PST-buy-FV 8food  
 “The children have bought (some) food.”

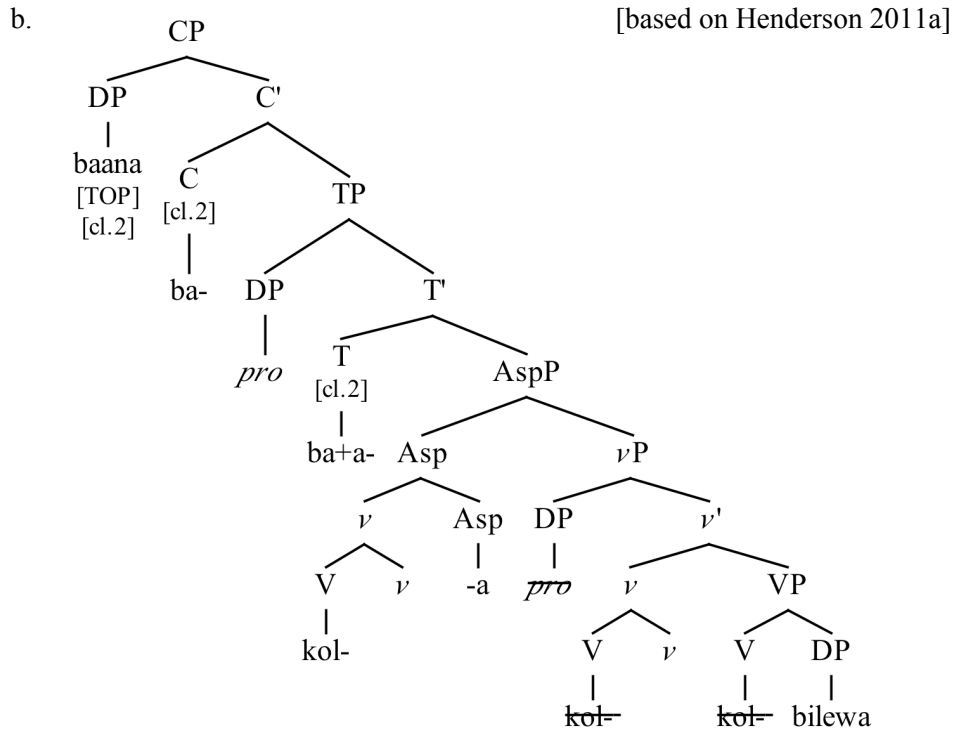

A null subject *pro*, co-indexed with the class 2 DP *baana*, is merged in spec, $\nu$ P, from where it is raised into spec,TP, attracted by an uninterpretable [TOP]-feature on C. The topic DP *baana* is merged directly into spec,CP. Of all Match relations the  $\phi$ -features of T have established (cf. MULTIPLE MATCH & UNRESTRICTED PROBING), they choose *pro* as their closest goal (cf. LOCAL AGREE) at the end of the derivation (cf. DYNAMIC LOCALITY), hence the subject marking on the verb. Of all Match relations the  $\phi$ -features of C have established, the closest match relation which will be turned into an Agree relation is that with *baana* in spec,CP. Note that C chooses the topic DP in spec,CP over *pro* in spec,TP as its closest goal, despite the fact they are equally distant (in terms of the number of nodes separating probes from goals). This constitutes a case of so-called symmetric locality. Granted it does not make any difference for declaratives in Bembe whether agreement of C is established with *pro* in spec,TP or with the topic DP in spec,CP since they are co-indexed and share the same referent, and thus the same  $\phi$ -feature sets. However, it does not become clear (at least to me) from Henderson's analysis how these asymmetries are formally resolved. In addition, as we will see below, they can prove to be problematic in some cases. Returning to the analysis of declaratives, the feature content of the probes in C and T is now identical, which, under the assumption that Kinyalolo's constraint also holds in Bembe, results in the deletion

of one of the two morphemes. This correctly predicts that what is spelled out at PF is the string in (490a), in line with the Bembe facts.

Let us evaluate how Henderson’s analysis fares with the variation in object relatives in Bembe, those constructions that proved to be most problematic for the previously discussed analyses. Recall that for languages like Bembe with postverbal subjects in extraction contexts, Henderson (2006) originally assumes only one preverbal A’-position. In his revised (2011) analysis, he allows for the possibility that Bantu languages have a parametric choice between projecting a spec,TP position and not doing so. This is to capture not only more variation between different Bantu languages but also, and more importantly for our purposes, variation within single languages.

- (491) *bilewa bi-ba-a-kol-á* (\**baana*). (Type 1 object relative)  
 8food 8REL-2SM-N.PST-buy-FV 2child  
 “the food that they have bought”

- (492) [based on Henderson 2011a]

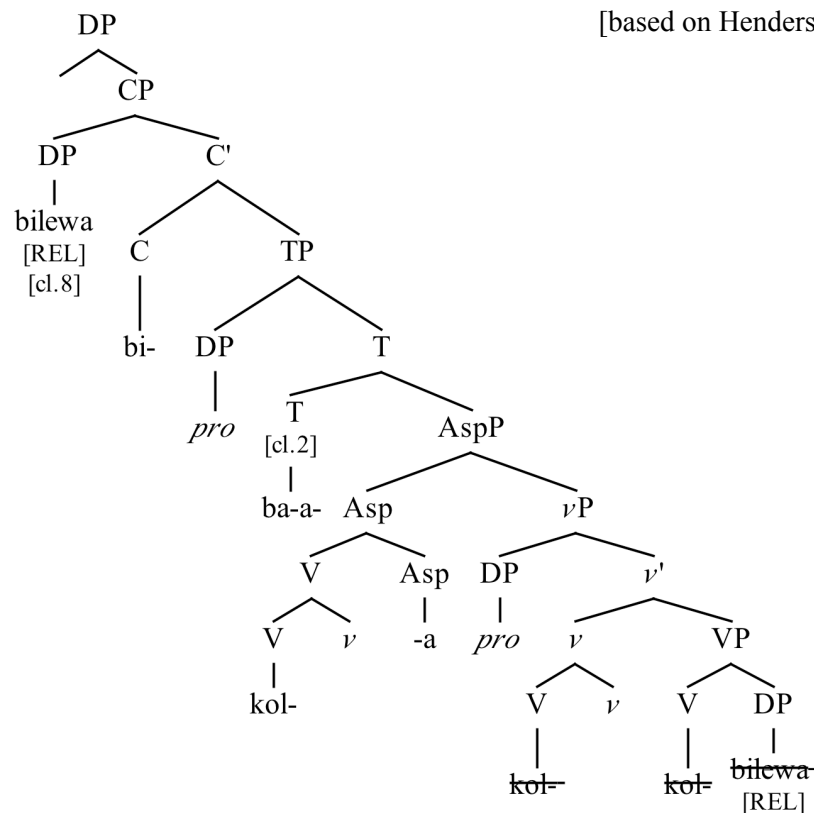

In the course of the derivation of a Type 1 object relative in Bembe, a null subject *pro* is merged in spec,vP, which is raised into spec,TP and matches the  $\phi$ -features of T. It will be chosen as the closest goal at the end of the derivation and be spelled out as subject

marker *ba-* on the verb. Of all Match relations the  $\phi$ -features of C entertain, they will choose those of the object DP *bilewa*, which has been raised into spec,CP due to its [REL]-feature, and agree with them. Note that we are again faced with a case of symmetric locality in Type 1 relative clauses: C is equally close to the null subject *pro* in spec,TP as it is to the relativised object in spec,CP. According to Henderson, such asymmetries can be resolved one way or the other by assuming that the probe simply chooses one goal over the other. Thus, in Bembe, it happens to be the case that C chooses to agree with the relativised object in spec,CP, yielding the class 8 relative marker *bi-*, as illustrated in (491)-(492), and as a result the derivation yields a Type 1 relative clause.

For a Type 2 object relative clause in Bembe, the analysis is not so straightforward. Consider the derivation of the example in (493) in (494).

- (493) *bilewa* *bi-a-kol-á* \**(baana)* (Type 2 object relative)  
 8food 8REL-N.PST-buy-FV 2child  
 “the food that (some) children/\*they have bought”

(494) [based on Henderson 2011a]

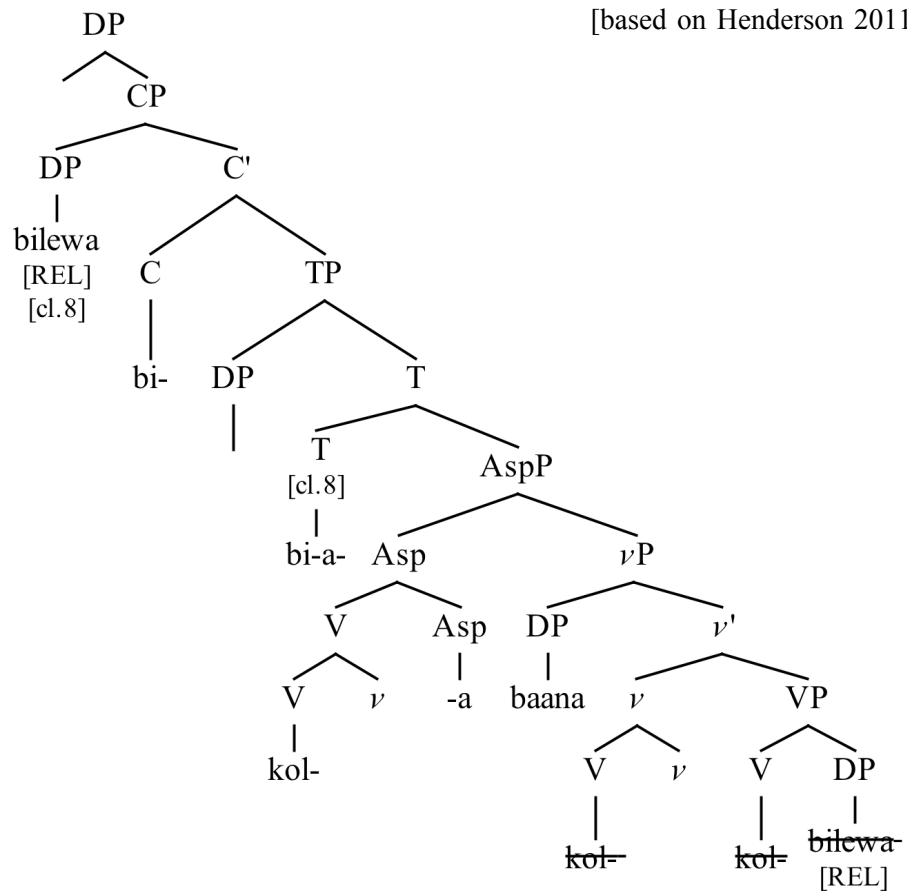

Besides a set of  $\phi$ -features, the object DP in (494) is equipped with a [REL]-feature which is responsible for lifting it into the spec,CP position. As regards the possible goals T has entered Match relations with, the one with C is the closest one, as a result of which T agrees with it.<sup>47</sup> C probes for a goal and has the choice between the equally local T and the relativised object in spec,CP. This being yet another case of the earlier-mentioned symmetric locality, Henderson assumes that any of the two goals can be chosen over the other. However, since the features of T have been valued by the features of C, we have to assume that C agrees directly with the relativised object in spec,CP, because a constellation under which C values T and T values C, would result in a non-convergent derivation, since both heads would vacuously value the features of each other. Note that spec,TP remains empty in the derivation of Type 2 object relatives, as the object *bilewa* is presumably raised directly into spec,CP. In conjunction with Kinyalolo’s constraint (the deletion of one of two morphemes with identical feature sets), the analysis correctly derives Type 2 relatives in Bembe.<sup>48</sup>

Subject relative clauses are derived by assuming that of all the Match relations the  $\phi$ -features of the probes entertain, the  $\phi$ -features on C will choose to agree with those of the relativised subject, which comes equipped with a [REL]-feature and thus gets attracted to spec,CP, which makes it the closest goal for C at the end of the derivation. As regards the  $\phi$ -features on T, they will choose the  $\phi$ -features of the relativised object via their Agree relationship with C, as C is the closest goal for T at the end of the derivation. Taking into account Kinyalolo’s constraint, the derivation in (495b) correctly yields the grammatical (495a).

- (495) a. *baana ba-a-kol-á bilewa*  
 2child 2REL-N.PST-buy-FV 8food  
 “the children who have bought (some) food”

47 Note that under Henderson’s assumption of rather traditional V-to-T movement, a case of symmetric locality would be given in (494) since both C and the subject DP in spec,vP would be equally close goals for T.

48 One could also evade symmetric locality by following Henderson’s (2011a) assumption that Bantu languages can exercise the parametric choice of not projecting a spec,TP position altogether. Thus, without a spec,TP position in the structure, C and T both would choose the relativised object in spec,CP (T via C) as their closest goal. In combination with Kinyalolo’s constraint, this would correctly derive the word order and agreement facts in Type 2 object relatives in Bembe, as illustrated below.

- (i) a. *bilewa bi-á-kol-a \*(baana)* [Type 2 relative]  
 8food 8REL-N.PST-buy-FV 2child  
 “the food that (some) children/(\*)they have bought”  
 b. [DP [CP *bilewa* C *bi-* [TP (*\*bi*)+*a-* [AspP *kol-a* [vP *baana* [vP *kol- bilewa* ]]]]]]

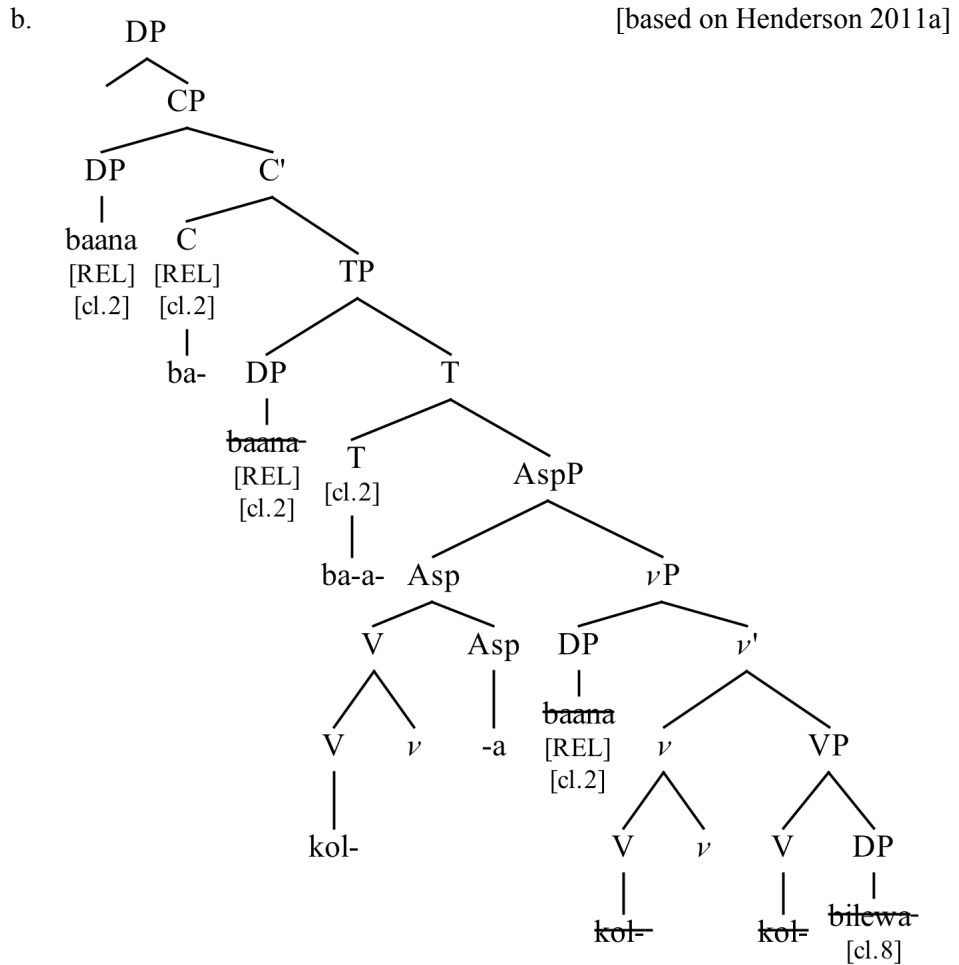

Alternatively, one could assume that Bembe makes the parametric choice to not project a specifier of TP in subject relative clauses, as made available under Henderson's account and illustrated in (496b). This would not change the agreement relations established in (495), as T would still agree with the relativised subject via C, and C directly with the relativised subject in spec,CP. Again, one of the two agreement morphemes which are identical in feature content is deleted as a consequence of Kinyalolo's constraint.<sup>49</sup>

49 Note that while the assumption that Kinyalolo's (1991) constraint holds in Bembe is essential in successfully deriving Type 2 relative clauses, it also raises questions. Consider the following example of a Type 1 relative clause in (i).

- (i) *baana ba-ba-sangan-ilé*  
 2child 2REL-2SM-meet-PST  
 "the children which they met"

The relative marker on the verb in (i) agrees with the relativised class-2 object *baana* while the subject marker also cross-references to the referent of a class-2 noun. Strictly speaking, this constitutes a case for Kinyalolo's constraint, according to which one of the two adjacent morphemes with identical feature content should be deleted. Thus, if we assume Kinyalolo's constraint (in its current formulation) to hold in Bembe, we predict that the simultaneous appearance of relative and



- (496) a. *baana ba-a-kol-á bilewa*  
 2child 2REL-N.PST-buy-FV 8food  
 “the children who have bought (some) food”
- b. [<sub>CP</sub> *baana* C *ba-* [<sub>TP</sub> T *ba(a)-* [<sub>AspP</sub> *kol+a* [<sub>vP</sub> *baana kol-* [<sub>VP</sub> *kol-bilewa* ]]]]]

A final testing ground for Henderson’s analysis is the Default Agreement Inversion, as illustrated in (497), in which subject agreement is with the default class 15 marker *ʔwa-* instead of the postverbal subject.

- (497) a. *ʔwa-a-chw-a baana.*  
 15EXPL-N.PST-come-FV 2child  
 “There have come/arrived (some) children.”
- b. [based on Henderson 2011a]

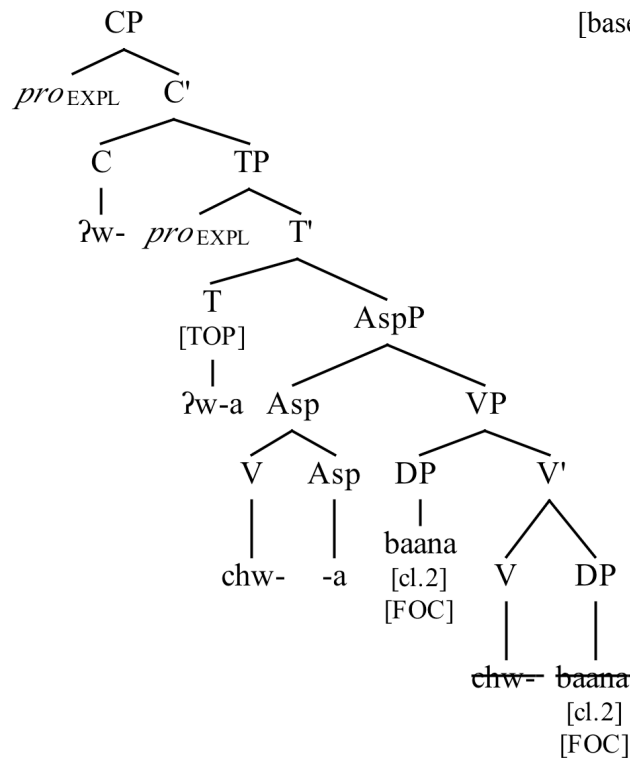

In (497), the verb moves from its base-generated position to AspP, forming the complex head *chw-a*. The logical subject is generated as DP in spec,vP. It is equipped with a [FOC] feature, in line with the fact that postverbal subjects in Default Agreement

---

subject markers of the same class should be prohibited, and thus incorrectly rule out grammatical cases like (i). One could circumvent the problem by specifying that Kinyalolo’s constraint only holds for adjacent morphemes which have the same feature content *and*, crucially, cross-reference the same referent (via indices).

Inversions receive a focus interpretation. A null expletive *pro<sub>Expl</sub>* is merged in spec,TP, which is the closest goal for T at the end of the derivation, as a result of which T agrees with the null expletive. As a result, the Agree relation between C and the null expletive is spelled out as class 15 marker *ʎwa-*. The same is valid for the probe C, which will choose the null expletive *pro<sub>Expl</sub>* as its closest goal at the end of the derivation, and establish an Agree relation with it. The result is the class 15 marker *ʎwa-*. Now, according to Henderson, the  $\phi$ -features on both heads C and T are strong in the sense that they attract their goals. Thus, one has to assume that the null expletive *pro<sub>Expl</sub>* is attracted to spec,CP. In conjunction with Kinyalolo’s constraint, one of the two identical morphemes is deleted before spell-out, as a result of which the analysis correctly predicts Default Agreement Inversions in Bembe.

### *Summary & Discussion*

In summary, we have seen that the Bembe agreement and word order facts in the discussed constructions are accounted for under Henderson’s (2011a) analysis. However, it does not come without problems. While I have not discussed negated structures, it is important to note that Henderson’s analysis makes the wrong predictions for Bembe in this respect. Consider the simple case of a simple negated structure, as in (498), for which I assume a Neg(ation)P(hrase) above TP (see Laka 1994; Zanuttini 1997 and Giorgi & Pianesi 1997 for arguments that a NegP above TP is a parametric option alongside of the more familiar order TP > NegP).

- (498) a. *Baana ta-ba-a-kol-a bilewa.*  
 2child NEG-2SM-N.PST-buy-FV 8food  
 “The children have not bought (any) food.”

- b. [<sub>CP</sub> *baana* C *ba-* [<sub>NegP</sub> *ta-* [<sub>TP</sub> *pro* T *ba+a-* [<sub>AspP</sub> *kol-a* [<sub>VP</sub> ~~*pro*~~ [<sub>VP</sub> ~~*kol-*~~ *bilewa* ]]]]]]]

The introduction of a NegP between the CP and TP projections will inevitably change the structure insofar as that C will always choose whatever element ends up in spec,CP as its closest goal (based on the number of nodes separating probes from goals) since T will now be always one projection further away from C than it is in affirmative structures. In addition, since a Neg head intervenes between the two heads C and T, Kinyalolo’s constraint cannot apply, thus resulting in the ungrammatical string *\*(baana) ba-ta-ba-a-kol-a bilewa*. Given that the Neg head will always intervene

between C and T, we are unable to derive any negated relative construction in which the verb shows only single operator agreement.<sup>50</sup>

One could alternatively assume that the order of functional projections is such that TP precedes NegP in Bembe, in which case movement of the negative head in front of the verbal complex would have to be made responsible for deriving the correct morpheme order, i.e. Negation > Tense, as in (499).

(499) [TP Neg T<sub>[φ]</sub> [NegP t<sub>Neg</sub> [vP...V...]]]

However, this would only defer the problem, as with the introduction of a NegP between T and vP, we are now faced with the dilemma of having T always choosing C as the closest goal over anything that occupies spec,vP. Any introduction of a NegP then proves to be problematic for deriving the attested word order and verb-marking patterns in Bembe under Henderson's account.

His analysis raises further questions, most notably in connection with the parametric choice of projecting a specifier of TP or not, his approach to the operation Agree and the resolution of symmetric locality. Admittedly, the latter phenomenon is a direct result of the liberal conditions under which probe-goal feature-valuation proceeds in his account, and there is not so much one can do about it other than accept it as a necessary consequence of his theory. Yet, it weakens Henderson's theory, which may be criticised on the basis of introducing a fair amount of arbitrariness into a system that should rather be characterised by the absence of it.

As regards Henderson's (2011a) claim that languages have the choice between projecting two (spec,TP and spec,CP) or only one preverbal position (spec,TP or spec,CP), I have already indicated in (491) and (492) that he, crucially, also contends that languages have this option available between them *as well as* within them. One could criticise that this choice makes the derivational system less than economical since it introduces an element of optionality, especially in the light of the fact that there is no formal motivation given as to why and in which cases a language should choose to project a spec,TP or not. Reinhart (1996, 2006) allows for cases of 'apparent optionality' but only under the premise that in such cases there exists a difference in interpretation between in-situ subjects (spec,vP) and ex-situ subjects (spec,TP). This is de facto what we find in Bembe: preverbal subjects must be interpreted as topics

---

<sup>50</sup> Admittedly, one could simply assume that NegPs are not taken into consideration for the calculation of existing Match relations due to the lack of φ-features on them. Henderson does not comment on this but simply notes the complication NegPs cause in his system.

(indicated by the asterisked quantifier), as shown in (500a), while postverbal subjects receive a focused reading (indicated by the asterisked definite article), as shown in (500b).

- (500) a. *Baana ba-a-chw-a.*  
 2child 2SM-N.PST-come-FV  
 “\*Some/the children have come.”
- b. *ɔwa-a-chw-a baana.*  
 15EXPL-N.PST-come-FV 2child  
 “There have come (some/\*the) children.”

Alternatively, one could dismiss Henderson’s optionality and insist that Bantu languages, such as Bembe, which do not show more than one preverbal element, are suggestive of having only one preverbal position, in particular no spec,TP position, rather than alternating between projecting and non-projecting one depending on the construction (cf. Henderson 2006). However, this alternative comes at a price, too. As we have seen, while Type 2 object relative clauses can be easily derived without assuming a spec,TP position for Bembe, Type 1 object relative clauses are not so straightforward, as non-projection of a specifier of TP immediately raises the question as to how T can agree with a null subject *pro*, if there is no position available to the null subject *pro* in the first place. Notwithstanding, agreement on the verb is with the null subject *and* the relativised element. In contrast, if one assumes that Bembe always projects a specifier of TP regardless of the construction involved, one ends up with the problem of being unable to account for why null subjects can seemingly raise into that position in Type 1 object relatives, while subject DPs are not allowed to in Type 2 relatives, although the latter possibility is predicted under Henderson (2011a).

While I agree that optionality should be allowed under the conditions formulated in Reinhart (1996, 2006), i.e. as long as it comes with a difference in interpretation, this does not mean that the difference in interpretation has to come about necessarily as the result of an optionally available spec,TP position in Bembe. Rather, I start from the assumption that in Bembe there is no spec,TP position altogether. The reason for this is found in the syntactic status of the verbal morphology, which I claim to be pronominal. From here, it follows that preverbal subjects cannot be in the same inflectional domain but must be dislocated, which also explains their A’-properties we have identified earlier. I do not deny that there may be optionality in Bembe, which is tied to a

difference in interpretation. However, I simply claim that this optionality does not concern the projection or non-projection of a spec,TP position, but rather which element is inserted in the numeration. It is from here, I claim, that everything else falls into place. I will explain myself in more detail in the next section.

#### **4.3.6 A proposal**

Let us begin with the important insight that the sentential domain in Bembe is divided into a preverbal topic and a postverbal focus-field. If you couple this with the fact that subjects are topics and do not have to be pronounced overtly in Bembe but can be expressed via subject markers on the verb (under the condition that the anterior discourse or context allows for sufficient identification of the topic referent), it becomes clear that Bembe does not necessarily have to move overt topic expressions into a preverbal spec,TP position. Rather, it is sufficient to express topical referents via subject markers on the verb, which precludes the need for a spec,TP position. In fact, if one were to go so far as to propose to analyse subject markers as being pronominal elements rather than grammatical-agreement morphology, which would also explain the A'-properties of preverbal elements, the information-structural content of the two types of object relative clauses could be simply expressed by two spec,TP-less structures in Bembe; either in the form of a Type 2 relative clause, which renders the postverbal subject DP focused, or in the form of a Type 1 relative clause, which renders non-overt subject DPs topical. Rather than insisting that these two constructions have different underlying structures (active/inactive spec,TP) as Henderson (2011a) would claim, I start from the assumption that all constructions in Bembe share an underlying spec,TP-less structure, which is a consequence of subject markers being pronominal, and in particular, of being the spell-out of an Agree relation between  $\phi$ Ps and T. If this is on the right track, we will be able to eradicate the ambiguity introduced by the (seemingly random) choice of projecting or not projecting a specifier of TP, as proposed by Henderson.

We have seen that one of the main reasons that led Henderson (2011a) to allow languages to opt between projecting a spec,TP position or not is the fact that Bantu languages like Zulu and Lingala allow two types of relative clauses. In one of them we have to account for the possibility of preverbal subject DPs. We therefore also assumed that the option to choose between an active and an inactive spec,TP position would be available to Bembe, given that the same variation exists with respect to relative clauses.

However, strictly speaking this is not the case, as we have seen that subject DPs actually never raise in Bembe relative clauses but stay low whenever they figure in the derivation. The only reason for assuming a spec,TP position in the above analysis of Type 1 relatives was to accommodate the null subject which is traditionally assumed to be the weak pronoun *pro* in generative analyses, which is able to move only to specifiers. There is however, as I believe, an alternative explanation as to why only null subjects are able to control agreement on the verb simultaneously with relativised objects and which is in accordance with Henderson's (2006) claim that Bantu languages are parametrised as to whether they have an active vs. an inactive spec,TP position, without intra-language variation in this latter respect.

One way to look at this is to assume that subject markers are the result of an agreement relation between a probe and a  $\phi$ P, a maximal and minimal category, instead of the weak pronoun *pro*, as claimed by Holmberg (2005, 2010), who applies Roberts' (2010) proposal for object clitics in Romance (see Chapter 3), to subject agreement morphology in consistent null subject languages. That is, if we treat the subject marker, more specifically, as the spell-out of an Agree relation between T and a clitic  $\phi$ P, the latter of which is forced to incorporate into its probe, this would preclude the need for an active spec,TP position in Bembe.<sup>51</sup> I claim thus, contrary to Henderson (2011a), that Bembe does not have the choice between an active and non-active spec,TP position depending on the construction involved, but rather that a spec,TP position is never projected (cf. Henderson 2006). This is in line with the ban on preverbal subject DPs other than topics or specific-indefinites, and the other characteristics of preverbal DPs we have identified in section 4.2.2. This lack of a spec,TP position is ultimately to be attributed to the simple fact that null subjects in Bembe are not the spell-out of an agreement relation between a probe T and a weak pronoun *pro* but rather with a clitic, i.e.  $\phi$ P (Roberts 2010a,b). These are minimal/maximal categories, the features of which are a subset of the features of the probe. Roberts claims that it is exactly this defectiveness of  $\phi$ Ps that forces them to incorporate into their probes. As a consequence, incorporation of subject  $\phi$ Ps precludes the need for a specifier position. The lack of preverbal subject DPs in object relatives would be accounted for by the distinct syntactic status  $\phi$ Ps and subject DPs have. The former are heads which are able to (and in fact must) incorporate into T, yielding a Type 1 relative clause, whereas DPs

---

51 My consultants have been reluctant to accept topicalisation constructions in which the object is preposed and the subject is also preverbal, which supports the assumption that Bembe has only one preverbal position available (*Bilewa, (??baana) ba-a-bi-kol-a* [= "The food, they/??the children bought it."]).

are phrases, which have nowhere to raise to and thus remain low in spec, $\nu$ P (given that spec,CP is occupied by the relative operator already), thereby yielding a Type 2 relative clause. An analysis along these lines seems attractive since it would allow us to develop a unified analysis of subject and object markers in Bembe, since both would count as simple spell-out of Agree relations between  $\phi$ Ps and probes.

*Analysis*

Let us begin then to outline the analysis of a Type 1 object relative clause, which has proven to be one of the most problematic cases for the approaches we have considered so far. Remember that the verb shows simultaneous relative and subject marking morphology, as illustrated in (501).

- (501) a. *bilewa bi-ba-a-kol-á* (Type 1 object relative)  
 8food 8REL-2SM-N.PST-buy-FV  
 “the food that they have bought”

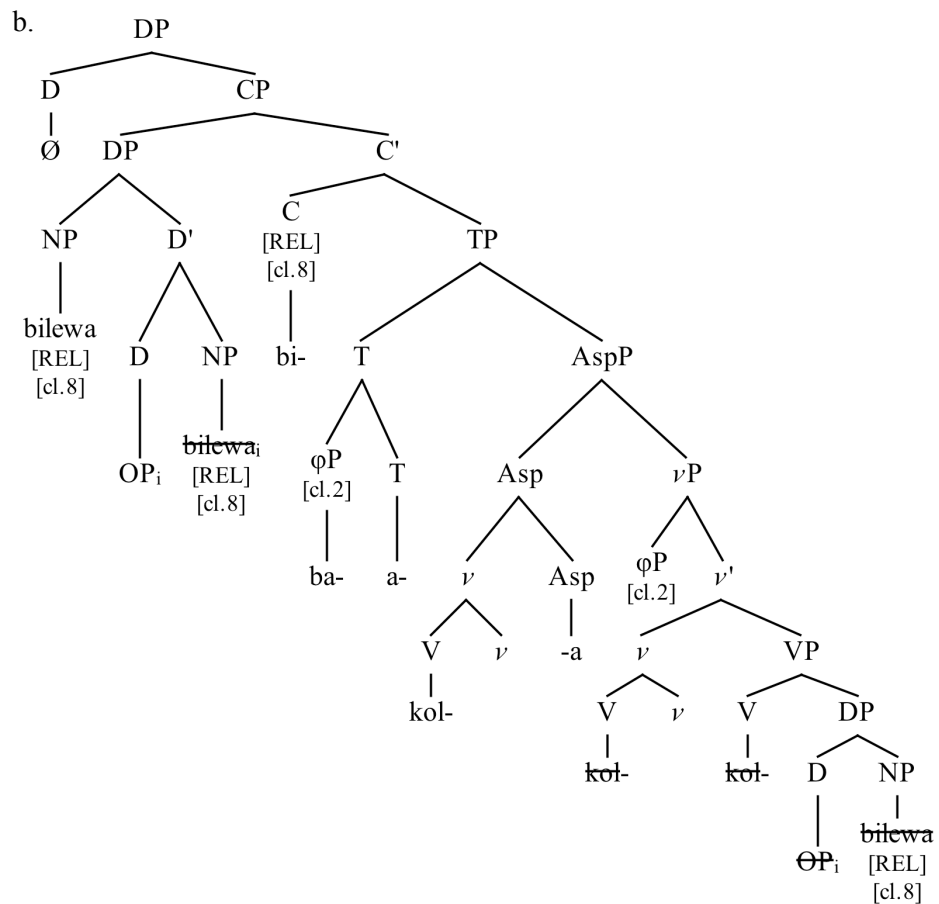

For relative clause structures, I assume that there is a [REL]-feature on C, responsible for attracting an object or subject DP to spec,CP. In line with Kinyalolo (1991), Carstens (2005) and Henderson (2006, 2011a), I also assume that C and T both bear a set of  $\phi$ -features, which act as probes. In Bembe, this assumption is necessary in order to account for the simultaneous relative and subject marking on verbs in Type 1 relative clauses. The verb moves from V-to-*v*-to-Asp. Given that a subject marker figures on the verb in Type 1 relative clauses (as opposed to Type 2 object relative and subject relative clauses), I assume that it is the subject clitic in the form of a  $\phi$ P that is merged in the canonical subject position in spec,*v*P, where it receives a theta-role. Once T is merged with a set of unvalued  $\phi$ -features, it will probe for a goal. The closest goal it will encounter at this point will be the  $\phi$ P in spec,*v*P, with the result that they enter an Agree relation, as a result of which the  $\phi$ P values the unvalued  $\phi$ -features of T. Given that the probe T has a rich enough set of unvalued features, the features of the  $\phi$ P are a subset of the features of T, and thereby be a copy. Two copies of the defective clitic now exist and form a chain, of which according to standard condition on chain reduction only the highest member will be pronounced. Thus the  $\phi$ P in spec,*v*P is deleted and only that under T is spelled out, namely in the form of the class 2 subject marker *ba*-.

Subsequently, a CP is merged, the head C of which also bears a set of unvalued  $\phi$ -features (Carstens 2005; Henderson 2006, 2011a) and an unvalued [REL]-feature. C will probe for a goal, which it will first find in the  $\phi$ P which has incorporated in T, since it is closer than the object DP in verb-complement position. However, the  $\phi$ P will not be agreed with because we assumed earlier that Agree requires Full Match. Under this assumption, it follows that the  $\phi$ P cannot agree with the features of C, since it lacks the corresponding interpretable [REL]-feature.<sup>52</sup> Remember that, under Henderson's account, choosing the most local among all Match relations that C entertains would result in a case of symmetric locality, which would have to be resolved randomly by the computational system. The [REL]-feature, however, is found on the object DP, which together with its matching interpretable  $\phi$ -features satisfies the requirement of Full Match, and the object can thus agree with C. The object DP is raised to spec,CP and the Agree relation is spelled out in the form of the relative marker *bi*- on C.<sup>53</sup> Postulating

---

52 An alternative explanation as to why the features of  $\phi$ P cannot agree with the features on C could be the assumption that probes are not active anymore after having valued a goal. For the above analysis this would mean that the  $\phi$ P is deactivated as a result of having valued the features of T and not available for any subsequent feature-valuing operations. C continues probing until it finds the object DP in the VP. However, as I will show below, this is not a desirable in the light of other constructions in Bembe, in which the verb seems to agree more than once with a goal.

53 Agreement between C and the object DP in verb-complement position presupposes that Agree is possible across a 'strong phase boundary', i.e. *v*P, against current assumptions. The formal solution



Full Match as a prerequisite for Agree thus prevents a locality violation which would otherwise be incurred since C would choose the  $\varphi$ P over the object DP in spec,CP.

We see then that it is possible to derive Type 1 object relatives in Bembe by analysing subject markers, following Roberts (2010), as the spell-out of an Agree relation between the probe T and  $\varphi$ Ps, under the additional assumptions that there is a [REL]-feature on C in Bembe and that the operation Agree requires Full Match, in the sense that all features of probes and goals match. With this in mind, let us now turn to the derivation of Type 2 relatives, such as in (502).

- (502) a. *bilewa* *bi-a-kol-á* *baana* (Type 2 object relative)  
 8food 8REL-N.PST-buy-FV 2child  
 “the food that (some) children have bought”

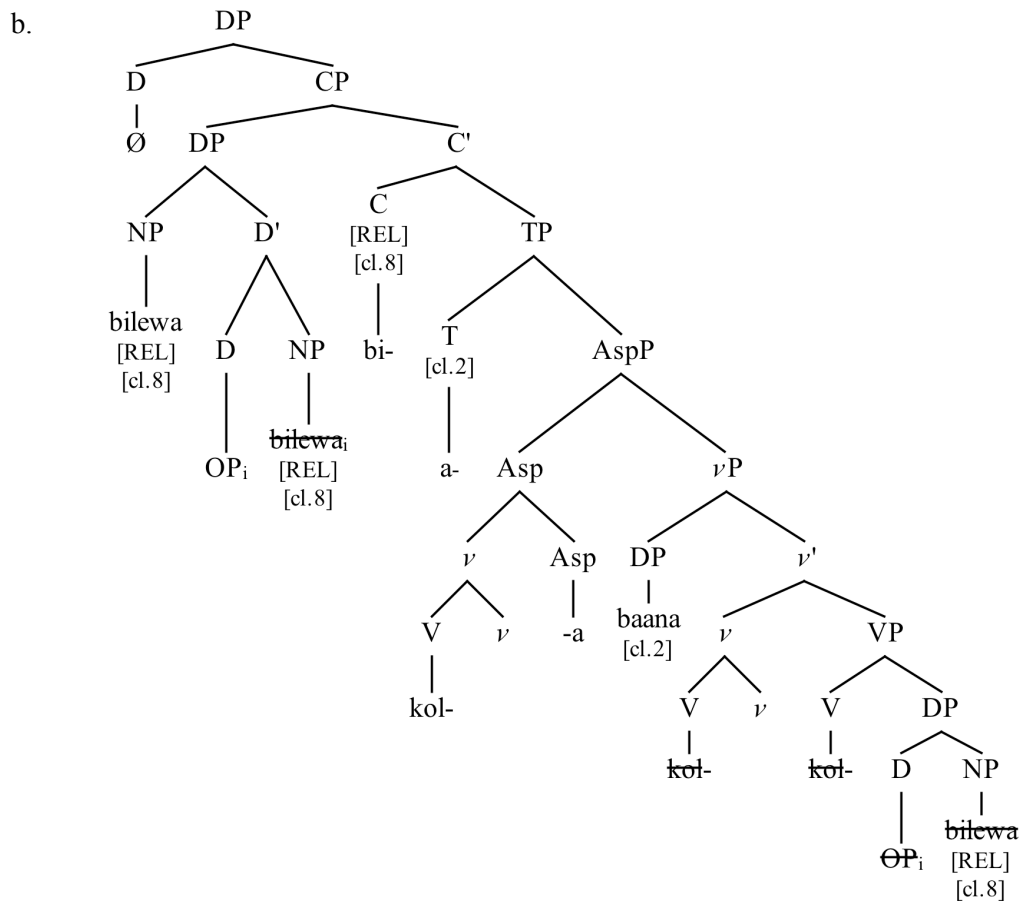

The derivation of a Type 2 relative clause is akin to that of a Type 1 relative clauses, as seen above. The difference is that a subject DP is merged in the specifier of  $v$ P instead

---

adopted in the literature is to assume that the object DP undergoes movement to the edge of the  $v$ P (Chomsky's (2000, 2001) *Phase Impenetrability Condition*), a view I also subscribe to.

of a  $\phi$ P. Once T is merged with a set of unvalued  $\phi$ -features, it will probe for a goal, and the closest goal it will encounter at this point will be the subject DP *baana* in spec, $\nu$ P. T agrees with the subject DP, but since there is no subject marking in Type 2 relatives, I conjecture that the Agree relation between the  $\phi$ -features of T and those of DPs is simply not spelled out in Bembe, due to the fact that DPs have features that are not represented in the probe, most notably a lexical root. They will thus not be a copy of the probe T. Subsequently, a CP is merged, the head C of which also bears a set of unvalued  $\phi$ -features (Carstens 2005; Henderson 2006, 2011a) and an unvalued [REL]-feature. C will probe for a goal, which it will first find in the  $\phi$ P incorporated in T, since it is closer than the object DP in verb-complement position. However, it will not agree with it but choose the object DP in verb-complement position, as it bears a matching [REL]-feature. As a result, the Agree relation between the two will be spelled out as *bi-*, thus correctly deriving the Type 2 relative clauses *bilewa biakolá baana*.

*Subject relative clauses*

The derivation of a subject relative clause is illustrated in (503).

- (503) a. *baana ba-a-kol-á bilewa*  
 2child 2REL-N.PST-buy-FV 8food  
 “the children that have bought food”

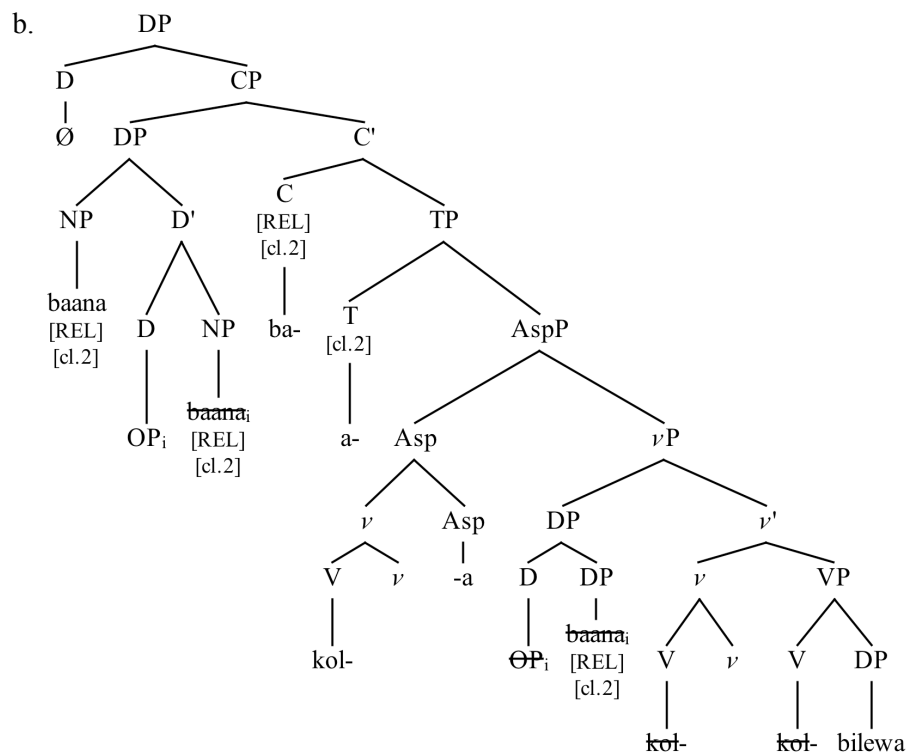

Once T is merged with a set of unvalued  $\phi$ -features in the structure, it will probe for a goal, and the closest goal it encounters at this point is the subject DP *baana* in spec,vP. T agrees with the subject DP but we have already seen in connection with Type 2 relatives, which do not show any subject marking either, that I assume that an Agree relation between the  $\phi$ -features of T and those of DPs is not spelled out in Bembe. Subsequently, a CP is merged, the head C of which also bears a set of unvalued  $\phi$ -features (Carstens 2005; Henderson 2006, 2011a) and an unvalued [REL]-feature. C will probe for a goal, which it finds in the subject DP in spec,vP, the [REL] and  $\phi$ -features of which fully match those of C. The subject DP is then raised into spec,CP as a consequence of the [REL]-feature on C.

Note that the presented analysis presupposes a view according to which goals remain active for further Agree relations despite having entered a prior one (contra Chomsky 2000, 2001). Roberts (2010) himself argues at length that defective clitics, i.e.  $\phi$ Ps, remain active, and further empirical support for such a claim comes from Carstens (2010) and Carstens & Diercks (2012) for Bantu in general. They provide evidence from a range of Bantu languages that Case features are absent in Bantu (see section 4.4.), and argue that instead the presence of interpretable gender features is responsible for what they term ‘hyperactivity’, i.e. multiple Agree relations between a goal and a number of probes. Since it is usually assumed that Case-feature valuation (as part of Agree) renders goals inactive for further Agree relations, the absence of Case features, in turn, implies that goals should not be deactivated after agreeing with a probe. If this is on the right track and thus goals remain active in Bembe, as a result, the features on C would agree with those of the subject DP that remains active, and the Agree relation between the two will be spelled out as class 2 relative marker *ba-*. This would correctly derive the subject relative clause *baana bakolá bilewa*.

We see then that an analysis according to which non-overt subjects in relative clauses are generated as  $\phi$ Ps in spec,vP is able to derive Type 1 relative clauses. In Type 2 and subject relative clauses, in turn, a subject DP figures in the numeration, which either stays postverbal or is attracted by a [REL]-feature on C into spec,CP, respectively. The assumption of C and T each bearing a set of unvalued  $\phi$ -features, and C additionally a [REL]-feature, in conjunction with the existing locality relations is able to derive the attested word order variability in Bembe relative clauses. Note that this

analysis also eliminates (at least in the case of subject relatives) the need for invoking Kinyalolo constraint.

*Declarative sentences*

One question that arises immediately with respect to the remaining types of constructions we have looked at so far, such as declaratives, locative inversions and default agreement inversions, is whether a movement trigger, comparable to a [REL]-feature in relatives, is also necessary to derive them, or whether one can dispose of it. Let us begin to find an answer to this question by presenting an analysis of declarative sentences, taking into account the insights we have made so far. Consider (504).

- (504) a. *Baana ba-a-kol-a bilewa.*  
 2child 2SM-N.PST-buy-FV 8food  
 “The children have bought some food.”

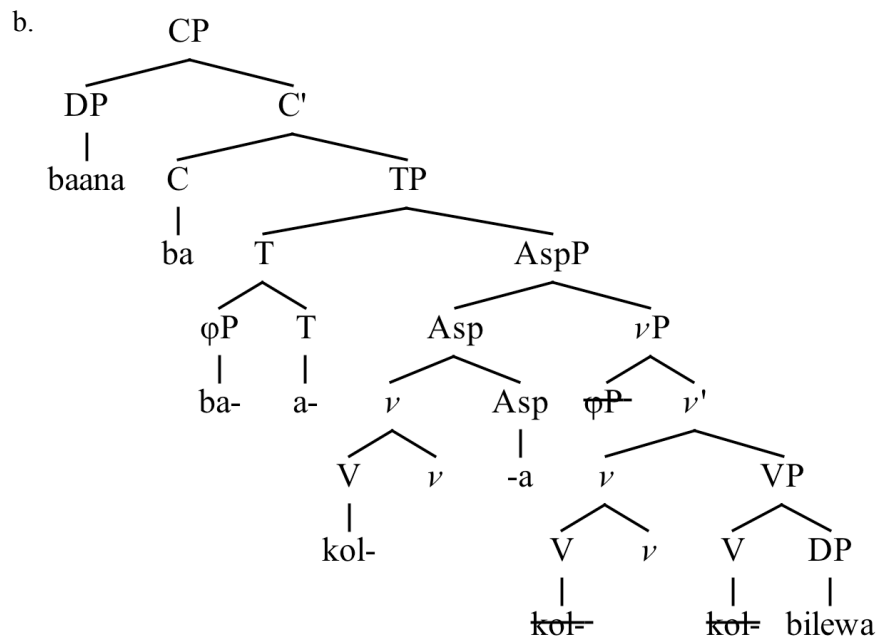

A VP is merged, which introduces the verb root *kol-*, and the complement of the verb, the class 8 object DP *bilewa*. Subsequently, a  $\nu$ P is merged, to which the verb moves. A class 2  $\phi$ P is merged in the specifier of the  $\nu$ P, functioning as the subject of the sentence. An AspP is merged above  $\nu$ P, to which the verb head-moves in order to pick up the final vowel *-a* qua left-adjunction. Afterwards, a TP is merged, the head T of which probes for a goal and finds it in the class 2  $\phi$ P. The features of the  $\phi$ P are a subset of the features of T, as a result of which a copy of the  $\phi$ P incorporates into T and agrees

with it. Two copies of the  $\phi$ P exist at this point, and under the standard condition on chain reduction, only the highest copy of the chain is spelled out. Thus, the Agree relation between T and the  $\phi$ P is spelled out as the class 2 subject marker *ba-* on T. In a next step, the feature-valuation requirement of the probe on C has to be satisfied. C probes for a goal, finds it in the  $\phi$ P that has incorporated in T and agrees with it, since it counts as closest goal to C. As a result, it is spelled out as *ba-*. Since both agreement relations of C and T spell-out as *ba-*, Kinyalolo’s constraint has to be invoked, according to which of two morphemes with identical feature content, one will be deleted, giving us the correct output *bakola bilewa*. In a final step, the DP *baana* is merged into the specifier of CP.

One minor but not unimportant question that arises at this point is which of the two morphemes is deleted. Consider in this respect the example of a subject relative clause in which the relativised subject is a class 1 noun, as in (505).

- (505) a. *Mtu wa-a-kol-á bilewa* (Subject relative clause)  
 1person 1REL-N.PST-buy-FV 8food  
 “the person that has bought some food”
- b. *Mtu a-a-kol-a bilewa* (Declarative clause)  
 1person 1SM-N.PST-buy-FV 8food  
 “the person has bought some food”

As one can see, the class 1 relative marker is *wa-* (505a), and thus not identical with the subject marker, which is *a-* in the case of class 1 nouns (505b). If Kinyalolo’s constraint affected the second of the two morphemes, that is the subject marker, we would incorrectly predict *mtu wakola*, rather than *mtu akola*, to be the correct verb form in declarative clauses with class 1 nouns. This, however, is contrary to facts, and thus I assume that it is the first of two identical morphemes that Kinyalolo’s constraint deletes, i.e. the spell-out under the probe C.

Note that in the analysis presented so far there is no need to posit any additional movement trigger, responsible for raising the  $\phi$ P into T, such as a [TOP]-feature for instance, as the existing locality relations between probes and goals are sufficient to derive the attested word order and agreement facts. Furthermore, one unexpected but very welcome result of this is the fact that the here-presented analysis correctly predicts the ungrammaticality of subject-object reversals in Bembe since the subject will always be chosen as the closest goal by the probe T.

While we have so far discussed subject and object marking in isolation, it may be opportune to turn to structures in which subject and object markers appear simultaneously. The question that arises in this context is whether the proposed account predicts the correct output with respect to agreement in the case different  $\phi$ Ps (or their copies) feature in the structure. Consider in this context the derivation of a simple declarative sentence in which the object DP is replaced with an object marker.

- (506) a. *Baana ba-bi-koch-ile.*  
 2child 2SM-8OM-buy-PST  
 “The children bought them.”

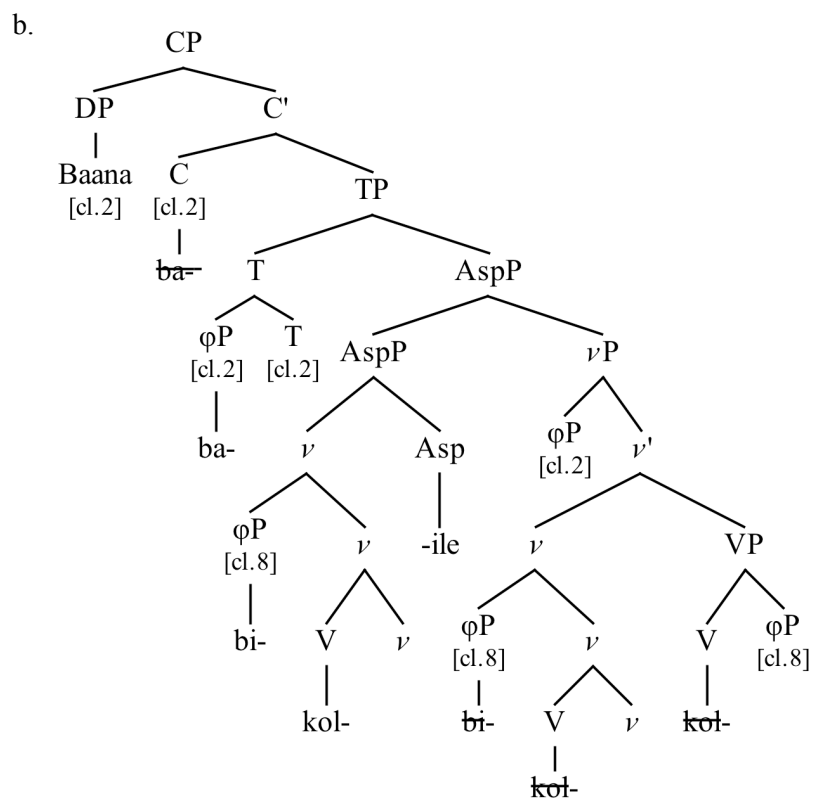

With respect to the structure in (506), one legitimate question one may want to pose is why the class-2 subject  $\phi$ P should be selected as goal for T over the more local class-8 object  $\phi$ P. Given the locality conditions, one would have to assume that it is the class-8 object  $\phi$ P that incorporates into T. If this were the case, we would incorrectly predict the spell-out to be *Baana a-bi-koch-ile* rather than the grammatical *Baana ba-bi-koch-ile*. I argue that it is impossible for T to choose the class-8 object  $\phi$ P, as this would constitute a case of excorporation (also referred to as successive-cyclic head

movement). The standard assumption in Generative theories is that complex heads are inseparable from a syntactic viewpoint, i.e. part of a complex cannot be moved to the exclusion of others, and excorporation is hence prohibited. A number of answers to this question have been offered. Baker (1988: 73) stipulates that the restriction derives from a ban on word-internal traces, whereas Ouhalla (1988: 15) claims that it follows from the *Head Opacity Condition*, according to which internal structures of complex heads are opaque to syntactic operations such as *Move  $\alpha$* . Others claim that the ban can be reduced to the Empty Category Principle (Ackema 1999), the requirement that traces be properly governed.

Roberts (1991, 1994 and subsequent work) forms an exception in that he allows for excorporation, however, only “under highly constrained conditions” (Roberts 2010a: 5), such as clitic climbing and verb-raising. Without going too much into detail, note that one thing these two conditions have in common is that the element in question is a single clitic. In constructions with simultaneous appearance of subject and object markers, such as (506), however, we are dealing with two different clitics. One of Roberts’ (2010a) implicit assumptions with respect to this is that different clitics must incorporate into different functional heads, which, he argues, is due to a lack of Case features on  $\phi$ Ps. If this is on the right track, and clitic climbing was excluded on the basis of missing Case features on  $\phi$ Ps in Bembe (see section 4.4) we could claim that different  $\phi$ Ps have to incorporate into different functional heads because it is impossible for these to discriminate between the two  $\phi$ P goals in any other way. In order to rule out cases in which T would agree with an object clitic (accusative/dative/applicative), excorporation is excluded. As a result, T in Bembe will always agree with the subject  $\phi$ P and never with an object  $\phi$ P.

Let us see whether the proposed analysis is able to capture the locative inversion facts in Bembe.

#### *Locative inversion*

Locative inversion constructions in Bembe show verb marking with the locative DP in grammatical subject position, but none with the postverbal logical subject. Additionally, the referent of the postverbal logical subject must be focused, either as informational focus or as part of a presentational sentence, in which every element is interpreted as being new information (indicated by small capitals in the gloss).

- (507) Mnumba      mwa-a-hingel-a      *baana*.  
 18LOC-9house 18SM-N.PST-enter-FV 2child  
 “Into the house entered CHILDREN.” or “INTO THE HOUSE ENTERED  
 CHILDREN.”

Before we attempt any analysis of locative constructions, we need to determine in detail whether and to what extent locative DPs have grammatical subject status. Apart from the locative marking on the verb, further evidence for the subject status of the locative DP comes from raising and relativisation. Consider the example in (508e), which shows that locative DPs can be raised to subject position of the matrix verb, just like subject DPs (508c).

- (508) a. *Baana* *ba-a-hingel-a*      *m-numba*.  
 2child 2SM-N.PST-enter-FV 18LOC-9house  
 “The children have entered (in) the house.”
- b. *Bi-a-hik-a*      *baana*      *ba-a-hingel-a*      *m-numba*.  
 8SM-PRES-seem-FV 2child 2SM-N.PST-enter-FV 18LOC-9house  
 “It seems (that) the children have entered (in) the house.”
- c. *Baana* *ba-a-hik-a*      *ba-a-hingel-a*      *m-numba*.  
 2child 2SM-PRES-seem-FV 2SM-N.PST-enter-FV 18LOC-9house  
 (Lit. “The children seem to have enter the house.”)  
 “The children seem to have entered (in) the house”
- d. *Bi-a-hik-a*      *m-numba*      *mwa-a-hingel-a*      *baana*.  
 8SM-PRES-seem-FV 18-9house 18SM-N.PST-enter-FV 2child  
 “It seems that (in) the house have entered (some) children.”
- e. *M-numba*      *mwa-a-hik-a*      *mwa-a-hingel-a*      *baana*.  
 18-9house 18SM-PRES-seem-FV 18SM-N.PST-enter-FV 2child  
 (Lit. “In the house seems have entered the children.”)  
 “(In) the house seems to have entered (some) children.”

Pushing aside for now the question of how non-raising verbs in raising contexts can be finite (to which I will return in section 4.4), the fact that locative DPs can be raised into subject position of the matrix clause is evidence that locative DPs have grammatical subject status.



Moreover, locative DPs can be relativised, as illustrated in (509).

- (509) a. *M-numba mwa-a-hingel-á baana.*  
 18-9house 18REL-N.PST-enter-FV 2child  
 “In the house which (some) children have entered.”
- b. *m-lobonga mu-ni-b-ile mo-hon-en-a*  
 18-11church 18REL-1SG-COP-PST PROG-pray-APPL-FV  
 (Lit. “in the church which (I) was praying in”)  
 “In the church where/which (I) was praying”
- c. *A-le ha-le i-ha-ba-a-ly-á mleka?*  
 16SM-COP 16where FOC-16REL-N.PST-2SM-eat-FV 3beans  
 (Lit. “It is where (that) they have eaten beans?”)  
 “Where have they eaten beans?”

I conclude then that locative DPs have grammatical-subject status in locative constructions, as a consequence of which they should occupy a position in the structure associated with that of the grammatical subject of the sentence.

As regards the structural representation of the locative inversion in (507), repeated here as (510a), I assume that, in analogy to other arguments of the verb, a locative class-18  $\phi$ P is generated in spec,VP. T probes for a goal and finds it in the locative  $\phi$ P. The features of the  $\phi$ P are a subset of the features of T, and are thus copied. The copy of the  $\phi$ P incorporates into T and agrees with it, as a result of which the Agree relation is spelled out as the class 18 marker *mwa-* on T. The two copies of the  $\phi$ P form a chain, and under the standard condition on chain reduction, pronunciation is restricted to the highest member of the chain, i.e. the  $\phi$ P in T. Subsequently, the  $\phi$ -features of C probe for a goal, find it in T and agree with the  $\phi$ -features of the latter. In conjunction with Kinyalolo’s constraint, this yields the correct result, as shown in (510).

- (510) a. *Mnumba mwa-a-hingel-a baana.*  
 18LOC-9house 18SM-N.PST-enter-FV 2child  
 “Into the house have entered children.”

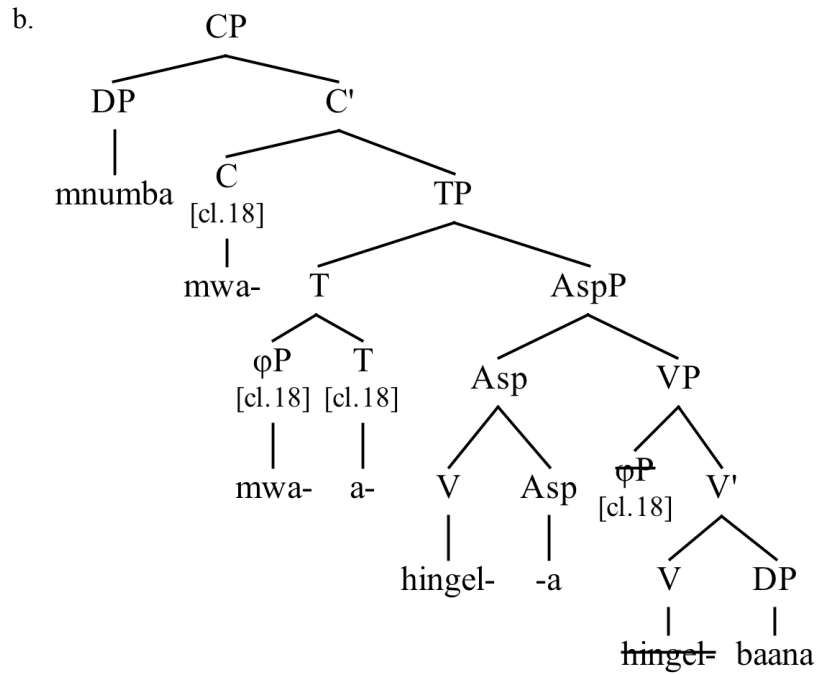

We see then that, also in the case of locative constructions, we can dispense with assuming a [TOP]-feature on either C or T, since the locality relations alone are responsible for deriving the attested word order and agreement facts. Let us see whether this holds for locative inversions with copular verbs, the second verbal alternative in Bembe locative inversions. Naturally, the structure of such a construction, shown in (511b), is similar to that of a non-copular locative inversion in (510b).

- (511) a. *Mnumba mu-le baana.*  
 18LOC-9house 18SM-COP 2child  
 “There are (some) children in the house.”

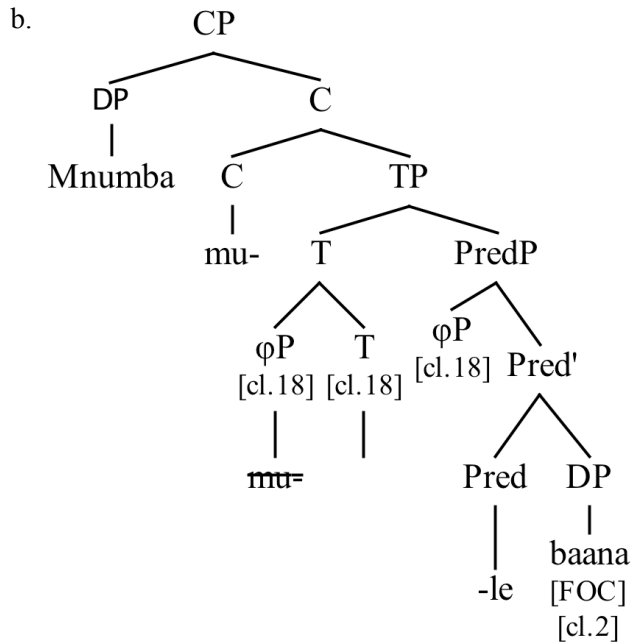

In (511b), a Pred(icate) P(hrase) is merged, which introduces the predicate root *-le*, and takes a DP complement. The locative class 18  $\phi$ P is merged in the specifier of PredP, which probes for a goal and finds it in the locative  $\phi$ P. The features of the  $\phi$ P are a subset of the features of T, as a result of which a copy of the  $\phi$ P incorporates into T and agrees with it. According to standard assumptions about chain reduction, only the highest copy of the chain is spelled out. Thus, the Agree relation is spelled out as the class 18 marker *mu-* on T. Subsequently, C probes for a goal and agrees with the features on T, which counts as closest goal to C. With the application of Kinyalolo's constraint, this yields the correct result, in line with (511a).

The representation in (512b) shows the derivation of a locative construction with a copular verb in the past tense, for which I additionally assume an AspP, to which the verb has to move in order for the final past-tense morpheme to appear as suffix on the copula *iba* 'to be'. With the exception of Merger of an AspP and subsequent movement of the copula to it, the derivation of (512) proceeds exactly as the one in (511b).

- (512) a. *M-numba mu-b-ile baana.*  
 18LOC-9house 18SM-COP-PST 2child  
 (Lit. "In the house were children.)  
 "There were children in the house."

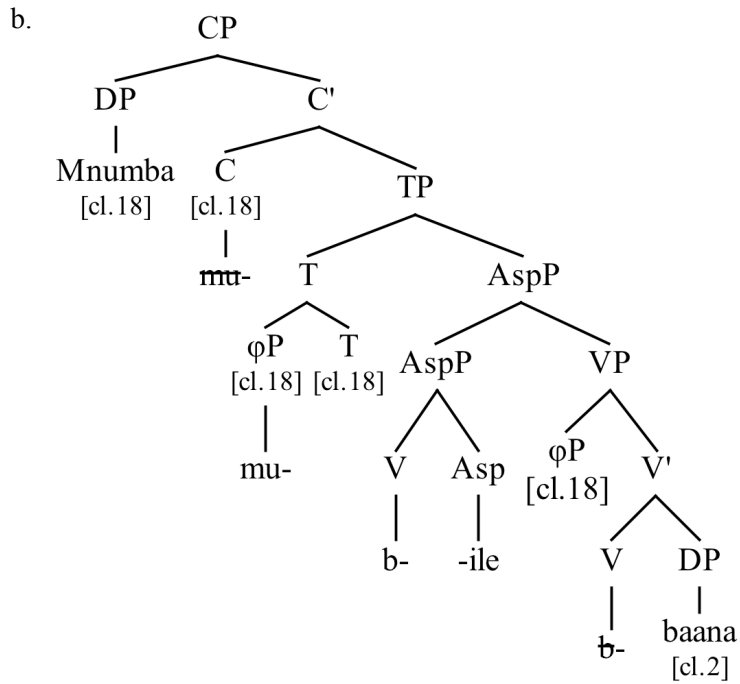

I conclude then that we do not have to assume an additional movement trigger such as a [TOP]-feature on either C or T in locative constructions, be it with a copular verb or an unaccusative one, since the attested word order and agreement facts are captured by the existing locality relations in the structure and the assumptions about the operation Agree made above. Let us see whether the same assumptions can be upheld for the derivation of default agreement inversions.

#### *Default agreement inversion*

Default agreement inversion constructions show default class 15 marking on the verb, while the focused subject DP, which must appear postverbally, does not induce verb marking. Moreover, the same transitivity restriction with respect to the verb types that are allowed in locative constructions, also hold for default inversions, i.e. only unaccusative and copular verbs are allowed. We want to maintain the assumption that probing under Agree is downwards in line with Chomsky (2000, 2001), hence the first question that arises is why T does not choose the subject DP *baana* in verb complement position as its goal in default expletive inversions.

(513) \**Ba-hingel-a baana.*

One could assume that the subject DP is blocked from being a matching goal by postulating a [TOP]-feature to be present on T. This would block the subject DP from being a matching goal since it bears a non-matching [FOC] feature. This implies that feature matching would have to involve Full Match of features between probes and goals, as we have already noted in the analysis of relative clauses above. Since the subject DP does not suffice the Full Match requirements, and given the absence of any other suitable goals, a default expletive marker is inserted in such cases to salvage the derivation from crashing at the interfaces. However, we have just seen that the derivation of locative and other constructions is possible without the assumption of a [TOP]-feature on C, and additionally offers an answer to the question as to why subject-object reversals are not grammatical in Bembe. Thus, I do not pursue this possibility further.

Another possibility as to how to ensure that agreement with T in default agreement inversion is not established with the subject DP, is to merge an expletive in a position above T, which T could agree with. However, this solution is undesirable, as it would imply upwards probing, a stipulation which we want to resist adopting for theory-internal considerations. In addition, external Merge of an expletive in spec,TP, as is standardly envisaged, implies the existence of a spec,TP position. This however I have dismissed earlier for Bembe since it makes the wrong predictions for object relative clauses. What is more, the traditional assumption of merging expletives in spec,TP has been criticised on the basis of a number of other problems. First, it cannot explain why in some languages only a subset of unaccusative verbs allow expletive insertion, creating contrasts such as in (514) in English.

- (514) a. *There arrived (some) children (at the school).*  
 b. \**There broke a window (at the school).*

Also, from a conceptual perspective, expletive insertion should be a property of phase heads (i.e. C and  $v$ ). Hence, expletives should be externally merged either in Spec,CP or in Spec, $v$ P. If an expletive occurs in Spec,TP, it should only do so as a result of internal Merge in satisfaction of an EPP requirement. Thus, postulating an expletive in a position above T does not seem like an attractive solution to pursue either.

There exists yet another possibility to account for default expletive constructions. The subject is merged as DP and not as  $\phi$ P since it is not topical but rather focused in default agreement inversions in Bembe. Now assume that T enters an Agree relation

with the postverbal subject DP but that this Agree relation is not spelled out because the features of the goal are not a subset of the features of T. Remember that this is a stipulation we have already made earlier for the derivation of Type 2 object and subject relative clauses. We would end up with a string consisting of a verb that bears the usual morphology, i.e. tense, extensions etc. except for a subject marker, and that linearly precedes the postverbal subject DP. One could go on to argue that there is a morphological constraint that prevents the verb from appearing with an empty initial slot, i.e. without subject marker, and that this constraint is satisfied by inserting a default expletive subject marker in the morphological component of the grammar. This is to some extent reminiscent of A&A's (1998) theory of EPP satisfaction via agreement morphology in null-subject languages. As a result we would correctly predict default expletive inversions in Bembe.

However, this possibility faces some problems. First, there is the question how to justify stipulating that there exists a morphological constraint which seems to hold in all cases except for that of imperatives, since the latter never display subject markers. Note that one would not only have to justify this with respect to Bembe but to all members of the Bantu language family. More importantly, however, if morphology were responsible for inserting a default agreement marker in the absence of any other goal, we would rob ourselves of an answer as to why default agreement inversion is restricted to unaccusative and copular verbs in Bembe, since T would agree with any subject. I conclude then that this is not as attractive a solution as it seemed at the beginning.

Finally, a much more elegant alternative is to assume that the expletive is merged in a position lower than T but higher than the object, i.e. sandwiched between the two. In that position, the expletive will be in the (downward) search domain of T and be chosen over the object DP as a matching goal simply due to being the most local one. A proposal in this direction comes from Richards & Biberauer (2005) and Richards (2007).<sup>54</sup> They propose that expletive *there* in English should be merged within the *vP*, more specifically in an outer *vP*, and that it eventually moves to the TP projection, in a process referred to as 'Merge-*vP*'. Their accounts are brought forward in an effort to explain the peculiarities of the distribution of expletives in Germanic languages, in particular German, Dutch and Afrikaans. To put the matter into a nutshell, providing a language with the option of projecting an additional specifier of *vP*, allows for transitive expletive constructions. English, presumably, does not project an additional spec,*vP*

---

54 Diercks (2012: 270) adopts a similar view, albeit attributing it to a proposal by Bowers (2002), according to which "expletives in different languages may be specified to merge in different positions."

position, whereby expletive constructions are restricted to unaccusative verbs, as the examples in (516) illustrate.

- (515) a. *There arrived a man.* (unaccusative)  
 b. \**There walked a man.* (unergative)  
 c. \**There read a man a book.* (transitive)

In analogy, the same ban on multiple specifiers could be taken as possible explanation as to why verbs other than unaccusatives are prohibited to appear in expletive constructions in Bembe, as shown in (516). Under the assumption that multiple specifiers are disallowed in Bembe, default inversions with unergative verbs, as in (516b), are excluded because unergative verbs have an external argument which would be left without Merge position in the presence of an expletive. The example (516c) is ungrammatical for similar reasons, that is, a subject DP would be in competition with an expletive for the specifier position of vP.

- (516) a. *ʔwa-a-chw-a baana.* (unaccusative)  
 15EXPL-N.PST-come-FV 2child  
 “There have arrived children.”
- b. \**ʔwa-a-tend-a baana.* (unergative)  
 15EXPL-PRES-speak-FV 2child  
 (Int. “There are children speaking.”)
- c. \**ʔwa-a-som-a baana etabo.* (transitive)  
 15EXPL-PRES-read-FV 2child 7book  
 (Int. “There children read books.”)

Without discussing Richards and Biberauer’s specific proposals any more in detail, as this would lead the discussion too far afield (but see Bošković 2002 for arguments against the view that expletives undergo movement, although the possibility of A’-movement is explicitly not discussed therein), let us see what such an analysis would look like when applied to Bembe. This is illustrated in (517).

- (517) a. *ʔwa-a-hingel-a*                      *baana*.                      (unaccusative)  
           15EXPL-N.PST-enter-FV    2child  
           ‘‘There have entered (some) children.’’

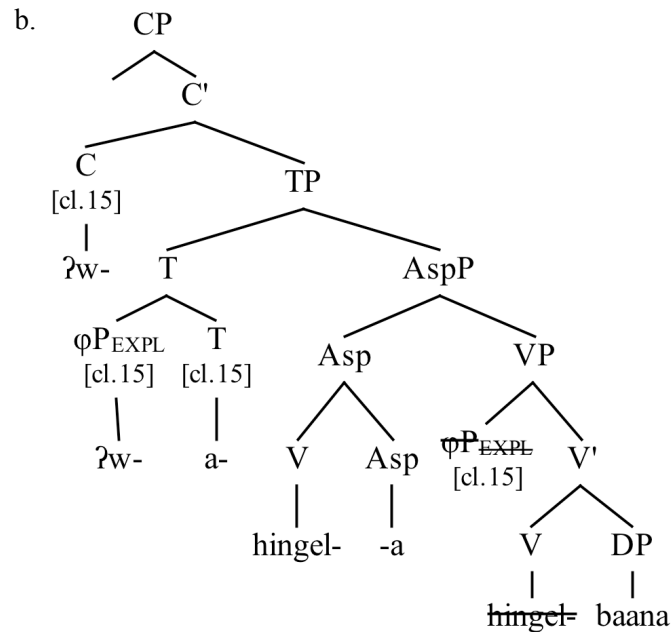

The verb moves from V to AspP (cf. Julien 2002) picking up the final vowel *-a*. T is merged and probes for a suitable goal, which it will find in the  $\phi P_{EXPL}$  in the spec,VP. I deviate from Biberauer and Richards’ assumption that null expletives are represented syntactically as *pro*, and analyse them as  $\phi P_{EXPL}$  in Bembe.  $\phi P_{EXPL}$  are non-referential and in no need of any antecedent. Their feature sets form a proper subset of the features of T, as a result of which the  $\phi P_{EXPL}$  is copied and incorporated into T (hence the spec,TP-less structure). Two copies of the  $\phi P_{EXPL}$  now exist and form a chain. According to the standard condition on chain reduction, only the highest member of a chain will be spelled out, namely as the class 15 default marker *ʔwa-*. In a final step, C agrees with the  $\phi P_{EXPL}$  which has incorporated into T. In combination with Kinyalolo’s constraint, according to which one of the two expletive markers is deleted, this gives us the correct result *ʔwaachwa baana*.

If this is on the right track and expletives in Bembe are in fact merged low in spec,vP, the transitivity constraint Bembe shows in default inversion constructions is explained by a ban on multiple specifiers, since Richards & Biberauer claim that expletives of transitive verbs are merged in an outer spec of vP. This would also provide us with a welcome answer as to why Bembe locative inversions are only possible with unaccusatives and copular verbs. Moreover, by merging an expletive low in spec,VP (in



the case of unaccusatives) or spec, PredP (in the case of copular verbs) in Bembe, we are able to maintain that probing under Agree is downwards and no reference to a [TOP]-feature or similar movement trigger on T need be made, as the existing locality relations alone are sufficient to derive the attested agreement relations for Bembe.

A question that has remained unanswered in connection to default agreement inversions is whether anything actually occupies spec, CP. Despite the fact that nothing seems to occupy spec, CP in default agreement inversions, it has been claimed for other languages that they actually involve a covert locative DP (Pinto 1997). Pinto's analysis is motivated by the observation that many Bantu languages display locative markers instead of an independent default expletive agreement and the fact that, with presentational readings, default agreement inversions often tend to have a 'here and now' interpretation. If the latter is on the right track and the same can be shown to hold in Bembe, we could posit that a null locative DP actually occupies spec, CP in default inversion constructions, which would in turn motivate the postulation of an EPP requirement in the form of a [TOP]-feature on C. Pinto's (1997) account makes two predictions with respect to default agreement inversion: if there is a null locative in spec, CP, it will presumably have some semantic content, so we should expect (a) a 'here and now' interpretation, and (b) that default agreement inversions should not be able to appear with other locatives that do not refer to the here and now. According to her, both predictions are borne out in Italian, as illustrated by the examples in (518) & (519) respectively.

(518) a. *Irene è arrivata a Milano.* (Italian; Pinto 1997:128, 130)

"Irene arrived at Milan."

b. *Irene è arrivata.*

"Irene arrived (somewhere)."

c. *LOC è arrivata Irene.*

"(here/at this place) arrived Irene."

(519) a. *Irene è arrivata a casa.*

Irene arrived at home

b. *\*E' arrivata Irene a casa.*

arrived Irene (here/at this place) at home

- c. *\*A casa è arrivata Irene.*  
 at home arrived Irene (here/at this place)

However, while class 15 and 17 markers in Bembe are indeed identical in form,  $\text{?w-}$  (underlying  $\text{?o-}$ ), as (520) shows, default agreement inversion in Bembe shows the absence of a ‘here and now’ reading (520b) and the ability to appear with other locatives that do not refer to the here and now (520c).

- (520) a. *O-lɔkolo            ?wa-a-chw-a            baana.*  
 17LOC-mountain 17SM-N.PST-come-FV 2child  
 “Onto the mountain have come (some) children.”
- b. *\*?wa-a-chw-a            baana*  
 15EXPL-N.PST-come-FV 2child  
 (Int. “(here/at this place) have come (some) children.”)
- c. *?wa-a-?w-a            baana Goma.*  
 15EXPL-N.PST-die-FV 2child Goma  
 “There died (some) children in Goma.”

On the basis of this data, I conclude that there is no motivation to postulate a covert locative DP that occupies spec,CP in default agreement inversions in Bembe.

#### *Discussion and summary*

We have seen that an analysis under which subject markers count as the spell-out of an Agree relation between T and a defective clitic, i.e.  $\varphi\text{P}$ , is able to derive the attested word order and agreement facts in Bembe. These  $\varphi\text{P}$ s are theta-role bearing arguments of the verb, which are base-generated in  $\nu\text{P}$ . and which, due to their defective nature, must incorporate into the head position in T. Incorporation of a  $\varphi\text{P}$  is taken to be a corollary of the operation Agree, where the features of the goal form a proper subset of the features of the probe. Incorporation thus precludes the need for an active spec,TP position in Bembe, which is particularly helpful in deriving the variation in subject and relative marking and the attested word orders in object relative clauses; a circumstance other analyses struggle to account for.

As regards the operation Agree, I maintain that downwards probing (in line with Chomsky 2000, 2001) in conjunction with the additional assumption that Agree

relations between T and subject DPs are not spelled out (since the features of these are not a proper subset of the features of T) captures the Bembe facts. This makes drastic changes to the feature-valuation mechanism (such as in Baker 2003, 2008; Carstens 2005; Henderson 2006, 2011a) unnecessary. Instead, the presented set of assumptions is sufficient to derive the discussed constructions without having to resort to a movement trigger, such as a [TOP]-feature on T. In fact, I have shown that nothing occupies spec,CP in default agreement inversions either, which suggests that a movement trigger on C is unnecessary too. Only in the case of relative clauses is a [REL]-feature on C present, which is responsible for raising the element to be relativised into spec,CP. However, in order to correctly predict Type 1 object relatives, a Full Match requirement has to be postulated with respect to feature valuation.

In the remaining constructions, i.e. declaratives clauses and locatives inversions, spec,CP is filled with a dislocated (and possibly null) A(boutness)-topic DP, which is responsible for providing  $\phi$ Ps with a referential value, since they enter the derivation as non-referential elements (cf. Frascarelli 2007; Holmberg 2010). This additionally explains the A'-properties of preverbal subject DPs in Bembe. However, there is nothing that suggests that a traditional EPP or any other movement trigger is present in Bembe. An unexpected but welcome result of not having to assume a [TOP]-feature on any of the probes in the analysis is that this predicts the ungrammaticality of subject-object reversals, in line with the Bembe facts. Note that it is not clear how the analyses we have discussed earlier would derive the ungrammaticality of subject-object reversals in Bembe. Moreover, the assumption that the derivation of locative constructions and default agreement inversions involves a defective  $\phi$ P as grammatical subject and null expletive, respectively, which are merged low (within the VP) (Bowers 2002; Diercks 2012), opens up the possibility to explain the transitivity constraints that hold in these two constructions in the form of a ban on multiple specifiers (cf. Richards & Biberauer 2005; Richards 2007).

We have also seen that the assumption that something like Kinyalolo's (1991) constraint holds in Bembe is necessary to derive the attested word order and agreement facts in Bembe, at least in the case of declarative clauses, locative constructions and default agreement inversions. One question that arises in this respect is whether the deletion of one of two morphemes with the same feature content could possibly be derived from a more general principle. Whenever we referred to the Agree relation between C and T, strictly speaking, what is meant is that the  $\phi$ -features of C agree with those of the  $\phi$ P that has incorporated into T. Now, since I subscribe to the view that

goals remain active, whenever C agrees with a  $\phi$ P under T, this  $\phi$ P should move further and incorporate into C. This operation would still be conceived as a copy operation, with the result that the copies of the  $\phi$ P form a chain. The usual conditions on chain reduction apply, according to which only the highest member of the chain is pronounced, hence the spell-out under C. If this is on the right track, the presented analysis would allow us to derive Kinyalolo's constraint from the standard conditions on chain reduction, a much more general principle. However, as we have seen in the analysis of declarative clauses, the verb morphology suggests that it is rather the higher one of the two morphemes that is deleted (cf. (504) & (505)).

#### 4.4 Circumstances alter cases

One last issue that needs to be addressed is that of case assignment. The question that arises in particular in this regard is how nominative case assignment to the postverbal subject DP in default agreement inversions takes place, although the question is equally important in the context of Type 2 relatives, where we find subject DPs in postverbal position. Baker's (2003, 2008) explanation as to how the Case features of postverbal subject DPs are valued is not transferrable to Bembe since Bembe does not feature augments (or pre-prefixes). Carstens (2005), in contrast, proposes that there exists a separate Agree relation between T and the postverbal subject DP, the sole purpose of which is to assign Case. This agreement relation is assumed to be independent of the  $\phi$ -feature Agree relation, and, in contrast to the latter, not realised at PF. Supposedly, the subject DP must probe the c-commanding structure in order to find suitable interpretable Case features, which it will find in T. However, it seems odd to argue that the covert Case agreement-relation is the result of the subject DP probing its c-commanding structure, while the visible  $\phi$ -feature agreement-relation results from T probing its c-commanded structure. In addition, since Case-feature valuation has been dissociated from the operation Agree, Carstens does not present any independent motivation for her Case agreement-relation other than Case-feature valuation itself, which makes her proposal of a distinct Case agreement operation seem more unlikely.

Generally, it has been assumed that Nominative Case can be assigned to postverbal DPs without the necessity for the latter to move to spec,TP, the position, which is traditionally taken to be the locus of Nominative Case assignment. This is accomplished via a process referred to as *Case transmission* (Chomsky 1981, 1986; den Besten 1985; Burzio 1986; Vikner 1995), according to which Nominative Case is

assigned to the non-argument subject in preverbal position and then transmitted to the logical subject in object position. Some even go so far to suggest that V directly assigns Nominative Case to the object in complement position (Pollock 1983). However, the common denominator of all these approaches is that a postverbal subject can receive Nominative Case despite being in the object position. Belletti (1988) rejects such approaches on the grounds that they would substantially weaken the *Unaccusativity Hypothesis*, the central assumption of which is that unaccusative verbs cannot assign accusative Case or the patient/theme-role to their complements. Instead, she claims that unaccusative verbs are able to assign an inherent Case referred to as *Partitive Case* to postverbal subjects, which, she argues, is suggested by the fact that postverbal subjects are usually indefinite. As we have seen, this is exactly what we find in the case of Bembe. Postverbal subjects in default agreement inversions can receive only an indefinite interpretation. However, it has been noted that postverbal subjects are not necessarily indefinite in all languages, which weakens Belletti's claim about Partitive Case assignment.

One, admittedly simpler, alternative would be to follow Diercks (2012) in his claims that Bantu in general lacks unvalued Case features, which would make the question as to how the postverbal subject receives Nominative Case obsolete.<sup>55</sup> Diercks (2012) argues on the basis of missing morphological case and the associated syntactic effects that *uCase* features are not present in Bantu.<sup>56</sup> Diercks proposes to capture this observation in the form of a macro-parameter according to which *uCase* features are either present or absent in a language, and the value of which is set negatively for Bantu. Consider (521).

(521) a. Case Parameter: Uninterpretable Case features are/are not present in a language.

b. Case Parameter, Bantu: Uninterpretable Case features are not present.

---

55 If this is on the right track, it would also follow that Baker's explanation as to why only null (but not DP) subjects can raise in Bembe relatives, namely due to T not checking *uCase* features, cannot be the correct.

56 In a similar vein, Carstens (2011) and Bošcović (2011) (following Epstein, Kitahara and Seely 2008), claim that uninterpretable features (such as *uCase*) can be present but need not be checked for a derivation to converge. They are simply ignored at the interface since they supposedly do not play an active role. Rather than uninterpretable features, it is an unvalued feature that causes a derivation to crash. However, it remains unclear how Case features of subjects are valued in postverbal position under such a view, considering that they are not in a position where they can be valued, but further discussion would lead us too far afield.

Diercks argues that if Bantu languages had *u*Case features, we would expect to see identical licensing conditions for NPs as in English (or any other language with Case for that matter). There is, however, ample evidence that quite the contrary is the case since in a number of Bantu languages NPs are licensed in contexts in which they should not be, according to traditional Case-theoretical assumptions.

Carstens (2010) and Carstens & Diercks (2013) assume that a feature other than *u*Case must be responsible for the hyperactivity of Bantu verbs and regard the Gender feature as a viable candidate. As a feature, Gender is meaningless and thus uninterpretable, hence it does not play any role under Agree in Bantu. Since there is nothing that renders goals inactive for further feature-valuation operations, this correctly predicts the deviating licensing condition observed by Diercks (2012). Van der Wal (2014) shares the view that Case may be parameterised but contends that Diercks' (2012) claims are probably too strong to be valid for the whole Bantu language-continuum. Instead, she proposes that Bantu languages could be parametrised as to whether agreement is linked to Case or some movement trigger like the EPP (or some other comparable feature).

Concretely, three predictions follow from Diercks' claim that Case features are absent: (a) the presence of licensed DPs in non-licensed positions, (b) the presence of licensed DPs in non-Case-marked positions, and (c) the ability of DPs to move out of positions in which they have had their Case-feature valued. Diercks starts to argue his case with the example of Locative Inversion in Bantu, a widely attested phenomenon in Bantu languages, including Bembe as we have seen (leaving aside for the moment its transitivity restrictions). Consider the examples in (522).

(522) a. *Chumba-ni mu-li-kuwa muzuri.* (Swahili; Buell 2007: 106)

7room-LOC 18-PST-be 18nice

“In the room was nice.”

b. *Mò-ngàndá mw-á-hítí òvá-ndù.* (Herero; Marten 2006)

18-9house 18-PST-enter 2-people

“Into the house entered (the) guests.”

c. *M-numba mwa-a-hingel-a baana.* (Bembe)

18LOC-9house 18SM-N.PST-enter-FV 2child

(Lit. “Into the house have entered children.”)

“There have entered (some) children into the house.”

- d. *M-numba mu-le baana.*  
 18LOC 9house 18SM-be 2child  
 “There are (some) children in the house.”

The locative DP moves to a preverbal position in order to value the EPP on T and subsequently agrees with T under Baker’s analysis, whereas T agrees with the locative DP and is then raised into a position above T to check the EPP feature of the latter under Carsten’s analysis. What is important though is the question how the Case features of the postverbal logical subject are valued if its  $\phi$ -features never agree with T. Since the case of the postverbal logical subject DP remains unvalued, the derivation should therefore not converge. On the other hand, if one assumes that *u*Case features are not present and therefore not relevant for the derivation in Bantu, this predicts that there should be examples in which DPs are not agreed with but are nonetheless licensed, something we exactly find in Locative Inversions.

That there exist further examples of licensed DPs in non-licensed positions is evidenced by the case of impersonal passives in some Bantu languages. Consider the examples in (523).

- (523) a. *Kw-á-uray-iw-a- mu-rímé né-shumba ku-rn-kova.* (Shona)  
 17-PST-kill-PASS-FV 1man by-9lion 17-11-river  
 “There was a man killed by a lion at the river.”
- b. *Ha-ra-shoor-w-a u-bu-kawáavu mu-rí i-yi sokó.* (Kirundi)  
 16-PRES-sell-PASS-FV PP-14-rabbits 18-be this-9 9.market  
 “There are sold rabbits in this market.” (Diercks 2012: 269)

In the examples above, the subject markers on the verb do not agree with any of the two arguments in the sentence, whereby we are forced to conclude that it instead agrees with an expletive subject. Crucially, the subjects are not in a Case-marking position and are thus barred from having their Case features valued. Under current minimalist assumptions, such examples should not be grammatical, yet they are attested.

Yet more examples of non-agreeing but licensed DPs can be found in transitive expletive constructions of the type exemplified in (524). Again, it is not clear (at least to me) how to account for the fact that the subject is licensed in a postverbal position despite not being agreed with.

- (524) *Ku-utshay-a u-Sabelo i-cuba.* (Shona)  
 17-smoke-FV u-Sabelo 9tobacco  
 “There is Sabelo smoking tobacco.” (Carstens & Mletshe, Forthcoming: 18)

While Bembe does not feature transitive expletive constructions like Shona, it does have impersonal passives. Agreement on the verb is with an expletive marker and not with any of the postverbal arguments, as illustrated in (525).

- (525) *ɔwa-koch-ilwe bilewa na baana.*  
 15EXPL-buy-FV.PASS.FV 8food by 2child  
 “There was food bought by the children.”

One could always argue, as done above, that an independent mechanism, e.g. a secondary Agree relation (cf. Carstens 2005), is responsible for valuing the Case-features. However, Diercks argues that instead of invoking additional mechanisms to the derivational system without any further motivation than Case-checking itself, it seems more reasonable to assume that Case features are simply not present in Bantu languages.

A second prediction that follows from Diercks’ assumption that Case is irrelevant in Bantu is that one should find examples of licensed DPs in non-Case-marked positions. For this purpose, he presents data featuring DPs in subject position of non-finite complements. DPs cannot be subjects of non-finite verbs because T is unable to value the Case of the embedded subject. An exception to this, however, are those cases in which verbs of superordinate clauses can ‘exceptionally’ value the Case of embedded subjects, as in so-called Exceptional Case-Marking (ECM). Since morphological case marking is not present in Bantu, the verb’s ability to be object-marked by the embedded subjects is seen as an alternative way of displaying cases of Exceptional Case-Marking. Consider (526).

- (526) *Ni-na-m-kubali pro a-som-e kitabu changu.*  
 1SM-PRES-1OM-allow 1SM-read-SUBJ 7book 7my  
 “I allow her/him to read his book.” (Swahili; Diercks 2012: 280)

Now, if one was to find examples of non-ECM constructions in which overt subject DPs were allowed as subjects of non-finite clauses, this would constitute evidence



against abstract Case in Bantu languages, since the case of the embedded subject would be left unvalued. He identifies this in what he refers to as ‘it-is-possible’ constructions. Consider the contrast between Swahili and English in (527).

- (527) a. *I-na-(\*m)-wezakana Maiko ku-m-pig-i-a Tegani simu.*  
 9SM-PRES-1OM-possible 1Michael INF-1OM-beat-APPL-FV 1Tegan phone  
 “It is possible (for) Michael to call Tegan.” (Swahili; Diercks 2012: 259)
- b. *It is possible \*(for) Mike to call Tegan.*

In the Swahili example in (527a), object marking, what has been taken as equivalent to morphological case-marking in Bantu, is ruled out, which qualifies the construction as a non-ECM-construction. But if the verb in this construction is a non-ECM-verb, which cannot assign morphological case to the embedded subject, the question as to what exactly is responsible for valuing the case of the subject remains unanswered. In contrast, under the single assumption that abstract Case is not present in Bantu languages like Swahili, examples like the one in (527a) are actually predicted to be grammatical. The example in (527b), in contrast, shows that “it is possible”-clauses in English can take a non-finite complement, however, only under the condition that a preposition be additionally introduced in front of the subject, which is responsible for Case-feature valuation. The same is possible in Digo and Lubusuku (528a-b respectively).

- (528) a. *I-na-wezekana Mike ku-muiha Tegan.* (Digo; Diercks 2012: 260)  
 9S-PRES-possible 1Mike INF-call 1Tegan  
 “It is possible (for) Mike to call Tegan.”
- b. *Ka-nyal-ikhana Sammy khu-khila ku-mw-inyawe o-kwo.*  
 6S-possible-STAT 1Sammy INF-win 3-3-game DEM-3  
 “It is possible for Sammy to win the game.” (Lubusuku; Diercks 2012: 260)

In contrast to English, the subject DPs of the non-finite clauses above are grammatical despite the lack of a preposition. Under the premise that the insertion of a preposition in such cases salvages the derivation from crashing by providing the subject with Case, the absence of such a preposition in Bantu is predicted under an approach that claims that

*u*Case features ought to be irrelevant in Bantu.<sup>57</sup>

Notice that the ability to allow subject DPs of non-finite verbs in non-case-marked positions without the use of a preposition does not have anything to do with the position of the subject of infinitives, as the contrast between (529) and (530) shows.

(529) \**(For) Michael to call Tegan would be a good thing.*

(530) a. *Sammy khu-khila ku-mw-inyawwe o-kwo khu-la-sanga-sya mawe.*  
1Sammy INF-win 3-3-game DEM-3 15S-FUT-please-CAUS mother  
“For Sammy to win the game will please his mother.”

b. *Ba-ba-ana khu-khw-ola muchuli khu-la-m-bukiya*  
2-2-children INF-INF-arrive tomorrow 15S-FUT-1<sup>ST</sup>SG.OM-surprise  
“For children to arrive tomorrow will surprise me.”

c. *Alfredi khu-khw-ola muchuli khu-la-khu-yeta khu-mala e-kasi*  
1Alfred INF-INF-arrive tomorrow 15S-FUT-1ST.PL.O-help INF-finish 9-work  
*yeno.*

DEM

“For Alfred to arrive tomorrow would help us finish the work.”

(Lubusuku; Diercks 2012: 261)

Bembe shows the same behaviour as the three aforementioned languages in these respects. In (531), the verb does not agree with either of the two arguments but instead is marked with the class 8 marker *bi-*, which acts as an expletive marker in this case.

(531) a. *Bi-nabashian-a (\* nibo) baana ba-koch-ile bilewa osoo.*  
8SM-be.possible.FV that 2child 2SM-buy-PST 8food 17LOC-market  
(Lit. “It is possible the children bought food at the market.”)  
“It is possible that the children bought food at the market.”

---

<sup>57</sup> Diercks (2012: 262–263) also presents data that corroborates that it is not the verb *to be possible* that licenses subject DPs with non-finite clauses by showing that the examples in (528) are not cases of Exceptional Case marking or Raising-to-Object constructions (both being cases in which the matrix verb would exceptionally license subject DPs in non-finite contexts).

- b. *Bi-nabashian-a baana i-kol-a bilewa osoo.*  
 8SM-be.possible.FV 2child 5SM-buy-FV 8food LOC-market  
 (Lit. “It is possible children bought food at the market.”)  
 “It is possible (for) the children to have bought food at the market.”

A third prediction that Diercks’ approach makes is that DPs should be able to move out of positions in which they have their Case-feature valued. Under current minimalist assumptions, in order for a DP to be able to act as goal, i.e. to be rendered active for the operation Agree, it has to have an abstract uninterpretable Case feature, which will be deleted once it is valued by an interpretable Case feature on a probe head (Chomsky 2000, 2001). A goal ceases to be active for further Agree relations once feature valuation has taken place. Thus, it is predicted that agreed-with DPs cannot raise out of positions in which they have been case-marked since they should count as inactive after feature valuation. Consider the English examples in (532).

- (532) a. [IP The thief is believed [IP [e] to be hidden in the cave]].  
 b. [IP \*The thief is believed [CP that [IP [e] is hidden in the cave]]].  
 c. [IP It is believed [CP that [IP the thief is hidden in the cave]]].  
 d. \*[ IP It is believed [IP the thief to be hidden in the cave]].

In (532a), the logical object *the thief* cannot receive Case from a non-finite verb and therefore must move to the matrix verb to receive its Case. For the same reason, (532d) is ungrammatical, as the object DP remains in a position in which it cannot receive Case. In (532b), the logical object cannot raise out of the subordinate clause because it has already had its Case valued by the lower verb. In contrast, the example in (532c) is grammatical because the object remains in a position in which it has received Case, and an expletive is inserted into the matrix clause. We would expect that the same holds for other languages. Consider though what happens in Shona, as shown in (533) (Diercks 2012: 277).

- (533) [IP *Mbavhá<sub>i</sub> i-no-fungir-w-a* [CP *kuti* [IP [e<sub>i</sub>]  
 9thief 9SM-PRES-suspect-PASS-FV that  
*y-aka-vánd-á mú-bako*]]]  
 9SM-FAR.PST-hide-FV 18-cave  
 “The thief is suspected to be hidden in the cave.”

In the Shona example in (533), we see that the DP *Mbavháí* has moved into the matrix clause and shows agreement with both verbs. However, under the theoretical assumptions made above, the example should be ungrammatical since the goal should not be able to agree with the higher probe once its Case feature has been valued by the lower one. But since both probes show class 9 agreement with the goal *Mbavháí*, we must assume that this is exactly what happens in (533), leaving open the question as to why the DP can move out of a case-marked position. In contrast, if one assumes that Case is not relevant in Shona, then the data is explained and the possibility is actually predicted since there is nothing in the operation Agree between the lower T and the DP goal which would render the latter inactive for further Agree relations.

A related argument comes from raising verbs such as *i-hik-a* ‘to seem’. Under traditional Case-theoretic assumptions for raising verbs, finite T licenses a subject DP. If in a complex clause, a lower clause is non-finite, the matrix finite T may instead license the subject. This explains why the subject of the embedded clause appears in the matrix clause in (534b). Once the Case-feature of a DP is valued, however, it cannot undergo any further operations, which explains the ungrammaticality of (534c).

- (534) a. It seems that the children bought food.  
 b. The children seem to have bought food.  
 c. \*The children seem that bought food.

Now consider the Bembe equivalents of (534) in (535), in particular (535b).

- (535) a. *Bi-a-hik-a*            *baana* *ba-koch-ile* *bilewa*.  
           8SM-PRES-seem-FV 2child 2SM-buy-PST 8food  
           ‘‘It seems (that) the children bought food.’’
- b. *Baana* *ba-a-hik-a*            *ba-koch-ile* *bilewa*.  
       2child 2SM-PRES-seem-FV 2SM-buy-PST 8food  
       (Lit. ‘‘The children seem have bought food.’’)  
       ‘‘The children seem to have bought’’

In (535b), the subject DP *baana* moves out of the subject position of the embedded clause into the subject position of the matrix verb. This, however, should be ungrammatical according to standard Case theory, since the subject already gets its Case

features valued in the embedded position and should thus be barred from undertaking further movement operations, which is suggestive of the absence of abstract Case in Bembe.

Moreover, Diercks cites so-called compound tense constructions (CTs) from Carstens (2001, 2010) as further evidence for his assumption that Case is irrelevant in Bantu. These are constructions that exhibit multiple agreement relations between one goal and a number of different probes. Consider (536).

- (536) a. *Juma a-li-kuwa a-me-pika chakula.* (Carstens 2001: 5)  
 Juma 1SM-PST-be 1SM-PRF-cook 7food  
 “Juma had cooked food.”
- b. (*Mimi*) *Ni-li-kuwa ni-ngali ni-ki-fanya kazi.*  
 I 1SG-PST-be 1SG-still 1SG-PRF-do 9work  
 “I was still working.”

In (536), the subject DP seems to have moved from a position in which it is assigned Case by T. Again, under Minimalist assumptions, this should not be possible, as Case-feature valuation renders a goal inactive for further Agree operations. In contrast, if one follows Diercks (2012), Carstens (2010) and Carstens & Diercks (2013) who argue that not Case but an interpretable Gender feature is responsible for rendering a goal active for entering an Agree relation, such examples are predicted, as interpretable features are not supposed to delete in the course of the derivation. This is illustrated in (537).

- (537) [T' Juma<sub>i</sub> [ T' a-li-kuwa [ASP' ~~Juma~~<sub>i</sub> [ASP' a-me-pika [<sub>vP</sub> ~~Juma~~<sub>i</sub> [<sub>VP</sub> t<sub>v</sub> [NP *chakula* ]]]]]]]

The subject DP is merged in spec,<sub>vP</sub>, raises to spec,AspP after which it agrees with the features of the probe head in Asp. Importantly, since Case features are not present in Bantu but rather some other interpretable feature, which is, crucially, not deleted in the course of the derivation, the subject DP can subsequently raise into spec,TP in order to agree with the features of the structurally higher head in T.<sup>58</sup> CTs are also featured in Bembe, namely with the past tense perfective, as in (538).

58 Carstens & Kinyalolo (1989) try to solve this problem by stipulating that there may only be a specific set of heads capable of valuing a Case feature. They explain the grammaticality of examples like (536) with the fact that only the head T with an *intrinsic* Case feature but not that of Asp can delete Case-features, an approach Diercks dismisses as less elegant than his own.

- (538) *Baana* *ba-b-ile* *ba-a-w-a* *i-ly-a*  
 2child 2SM-COP-PST 2SM-N.PST-finish-FV 5SM-eat-FV  
 (Lit. “Children were finished to eat.”)  
 “The children had eaten (already).”

Table 34 summarises the given arguments in favour of the view that abstract Case is absent in Bembe.

(a) The presence of licensed DPs in non-licensed positions:	
- Locative inversion	✓
- Impersonal passives	✓
(b) The presence of licensed DPs in non-Case-marked positions	
- <i>It is possible (*for) Iddi</i> + infinitive	✓
(c) Movement of already Case-valued DPs	
- Compound tenses (CTs)	✓
- [ <sub>IP</sub> <i>The thief<sub>i</sub> is believed</i> [ <sub>CP</sub> <i>that</i> [ <sub>IP</sub> [ <sub>e<sub>i</sub></sub> ] <i>is hidden in the cave.</i> ]]]	✓

Table 34: ARGUMENTS IN FAVOUR OF ABSENT *u*CASE FEATURES IN BEMBE

We see then that the arguments in favour of a view that claims that Case is absent in Bembe are abundant. This makes the question as to how the issue of Case is resolved under the proposed analysis, in particular in default agreement inversions, obsolete. Note that this also undermines Baker’s explanation that only null subjects (as opposed to DPs) can raise into the spec,TP position in object relatives because T is a non-case-assigning position, and *pro* being the only element that does not need its Case-feature valued. In the light of the compelling evidence Diercks adduces for his hypothesis that *u*Case features are not present in Bantu, I subscribe to his view and assume that Bembe does not feature *u*Case features either.

#### 4.5 Summary and conclusions

The chapter began with an introduction to subject marking and the variation one encounters across the Bantu languages, followed by a review of the recently revived theoretical debate surrounding its grammatical nature in Bantu and other null subject

languages. Subsequently I embarked on an analysis of the categorial status of subject markers in Bembe. In the latter, I sought an answer to the question whether subject markers should be treated as agreement morphology, pronouns, or as being ambiguous between the two, as a result of which I dismissed the view according to which subject markers are ambiguous between being agreement morphology and pronouns. Instead, I presented distributional and interpretational evidence which shows that preverbal subject DPs show topic-like properties, most importantly an obligatory wide-scope readings and a complementary distribution with subject markers (in the inflectional domain), which implies that they are always in a dislocated position. This, in turn, strongly suggests that subject markers are pronominal elements rather than grammatical agreement morphology.

As regards the structural make-up of the Bembe clause, I subsequently show how a traditional movement analysis, according to which subject markers are pronominal elements, struggles to account for the presented Bembe facts, as they are unable to give a reason as to why subject markers can raise to spec,TP while subject DPs have to stay low in object relative clauses. More recent grammatical-agreement analyses, in contrast, attempt to explain the perceived topic status of preverbal subjects in Bantu by assuming the presence of null subjects which are made responsible for determining agreement on verbs, such as Baker (2003, 2008) and Carstens (2005). Both analyses stress that Bantu languages defy Chomsky's latest (2000, 2001) approach to probe-goal feature valuation in that agreement seems to require a spec-head relation between probe and goal, and thus movement. In order to accommodate the Bantu facts, they modify the probe-goal approach to feature valuation. However, both Baker's (2003, 2008) and Carstens' (2005) proposals struggle to account for the different agreement and word order patterns in Bembe, most notably in the case of Type 1 and 2 relative clauses. In fact, under Carstens' analysis, Type 1 relative clauses are entirely ruled out, contrary to facts.

Subsequently, I showed that an account as presented by Henderson (2006, 2011a) who proposes the most far-reaching alteration to the feature valuation, is able to explain a variety of word order and agreement patterns across Bantu languages, in particular the variation in availability and agreement within single Bantu languages with regard to operator constructions (REL/TOP-V-S). Under Henderson's analysis, the availability of subject markers vs. preverbal subject DPs in object relative clauses is a matter of projecting a specifier of TP or not, which is treated as a matter of parameterisation between as well as within languages. However, his (2006) and modified (2012) account struggle equally to account for the differences in availability of preverbal subjects in

object relative clauses in Bembe. Ultimately, I conclude that his predictions are not entirely born out for Bembe either, as his analyses fail to predict attested word orders and verb-marking patterns.

I claim that the inability of the discussed analyses to account for the variation in Bembe object relative clauses and other constructions can be found in the fact that they are flawed in their initial assumption to treat subject markers as the spell-out of an Agree relation between T and a null subject *pro*. Instead, I propose that they should be analysed as the spell-out between T and pronominal  $\phi$ Ps. I continue by claiming that, following Roberts' (2010a,b) treatment of Romance object clitics, subject markers are defective clitic pronouns ( $\phi$ Ps), i.e. theta-role bearing arguments of the verb, which are base-generated in  $v$ P and which, due to their defective nature, must incorporate into the head position in T. Incorporation is taken to be a corollary of the operation Agree and follows from the fact that the features of  $\phi$ Ps form a proper subset of the features of the probe. It thus precludes the need for an active spec,TP position in Bembe. Despite being theta-role bearing arguments,  $\phi$ Ps are non-referential, and thus in need of a referential value, which is provided by a dislocated (and possibly null) A(boutness)-topic DP (Frascarelli 2007, Holmberg 2010), which additionally explains the A'-properties of preverbal subjects.

As regards the operation Agree, I maintain that downwards probing (in line with Chomsky 2000, 2001) in conjunction with the additional assumption that Agree relations between T and subject DPs are not spelled out in Bembe (since the features of these are not a proper subset of the features of T) captures the Bembe facts. This makes drastic changes to the feature-valuation mechanism (such as in Baker 2003, 2008; Carstens 2005; Henderson 2006, 2011a) unnecessary. Instead, the presented set of assumptions is sufficient to derive the discussed constructions without having to resort to a movement trigger, such as a [TOP]-feature on T. In fact, I have shown that nothing occupies spec,CP in default agreement inversions either, which suggests that a movement trigger on C is unnecessary too. Only in the case of relative clauses is a [REL]-feature on C present, which is responsible for raising the element to be relativised into spec,CP. However, in order to correctly predict Type 1 object relatives, a Full Match requirement has to be postulated with respect to feature valuation.

In the remaining constructions, i.e. declaratives clauses and locatives inversions, spec,CP is filled with a dislocated (and possibly null) A(boutness)-topic DP, which is responsible for providing  $\phi$ Ps with a referential value, since they enter the derivation as non-referential elements (cf. Frascarelli 2007; Holmberg 2010). This additionally



explains the A'-properties of preverbal subject DPs in Bembe. However, nothing suggests that a traditional EPP or any other movement trigger is present in Bembe. An unexpected but welcome result of not having to assume a [TOP]-feature on any of the probes in the analysis is that this predicts the ungrammaticality of subject-object reversals, in line with the Bembe facts. Note that it is not clear how the analyses we have discussed earlier would derive the ungrammaticality of subject-object reversals in Bembe. Moreover, the assumption that the derivation of locative constructions and default agreement inversions involves a defective  $\phi$ P as grammatical subject and null expletive, respectively, which are merged low (within the VP) (Bowers 2002; Diercks 2012), opens up a way to explain the transitivity constraints in these two constructions in the form of a ban on multiple specifiers (cf. Richards & Biberauer 2005; Richards 2007).

We have also seen that the assumption that something like Kinyalolo's (1991) constraint holds in Bembe is necessary to derive the attested word order and agreement facts in Bembe, at least in the case of declarative clauses, locative constructions and default agreement inversions.

Finally, in section 4.4, I discuss the issue of Case and the question of how Case-feature valuation takes place in the proposed analysis. Bantu languages do not show morphological case, and I presented evidence from Diercks (2012), which suggests that abstract Case is altogether absent in the Bantu language family. With respect to Bembe, evidence in the form of licensed DPs in non-licensed positions, licensed DPs in non-Case-marked positions, and the ability of DPs to move out of positions in which they have had their Case-feature valued lead me to conclude that the same is true for Bembe, and that, ultimately, *u*Case-features cannot play a part in the feature-valuation process. Instead, I follow Carstens (2010) and Carstens & Diercks (2013) who assume that a feature other than *u*Case must be responsible for the hyperactivity of Bantu verbs and regard the Gender feature as a viable candidate. As this feature is meaningless and thus uninterpretable, it does not play any role under Agree in Bantu. Since there is nothing that renders goals inactive for further feature-valuation operations, this correctly predicts the phenomenon of hyper-agreement and licensed DPs in non-licensed positions and non-Case marked positions.

## CHAPTER 5 - CONCLUSIONS

This thesis had two aims. One was to give a grammatical description of the under-documented Bantu language Bembe, which will serve as a general source of information for the like-minded researcher and equip the reader with the necessary knowledge for the chapters to follow. The second aim was to present a formal account of how to derive the variation in Bembe verb marking and its implications for word order within a generative theory of grammar, focusing explicitly on the domains of subject and object marking. This chapter concludes the thesis by summarising the findings and offering directions for further research.

### 5.1 Subject/object marking and word order

Chapter 3 introduced the reader to the properties of object marking in Bembe, decided on the question whether it should be treated as an agreement or rather a pronominal phenomenon, and presented a syntactic analysis which is able to capture the object-marking data, in accordance with recent minimalist assumptions. The chapter began by introducing the reader to the variation that exists with respect to object marking within the Bantu languages and the theoretical treatment it has received in the literature. Whereas most Bantuists favour a pronominal analysis of object markers for the majority of Bantu languages, this has been called into question by some who convincingly showed that this may not be necessarily true with respect to all members of this language family (see Riedel 2009).

In order to determine whether this may also be the case for object markers in Bembe, I applied a number of diagnostics standardly employed in the literature, the results of which lead me to conclude that they must be pronominal rather than agreement morphemes. In particular, the fact that there exist (i) an obligatory intonation break and (ii) interpretational differences in the presence of object markers, besides (iii) the co-occurrence restrictions between object marking and indefinite, focused, relativised, passivised elements and negative-polarity items, and (iv) the ungrammaticality of certain orderings of object-marked objects and other elements, points to the conclusion that object-marked objects are obligatorily dislocated. It follows that object markers, if they are in complementary distribution with lexical objects, must be pronominal in the sense of being theta-role bearing arguments.

I then proceeded to resolve the resulting question as to what kind of pronouns they could be, and concluded, in line with the diagnostics provided by C&S (1999), that they cannot be strong pronouns due to their inability (a) to be coordinated with other DPs, (b) to appear in the canonical object position and (c) to be clefted. Further evidence for this comes from their semantics, as they cannot be used ostensively either. Their phonological necessity to attach to a host, ultimately, lead me to analyse them as clitics, rather than weak pronouns. In particular, I followed C&S in analysing them as defective pronouns, i.e.  $\phi$ Ps. These are minimal/maximal categories that are stripped of their functional layer and are nothing else than bundles of features.

I argued for a representation of the verb in Bembe following Julien (2002), according to which the verb in Bantu only moves to a position below T (specified here as AspP). In contrast to the more traditional view of V-to-T movement of the verb, Julien assumes that the parts of the verb are formed differently: suffixes are the result of (iterating) head-movement, while prefixes are attached to the verb by a morpho-phonological process. This has the advantage of being able to account in a principled way for why some heads attach as suffixes while others appear as prefixes.

Subsequently, I reviewed and discussed a number of different proposals concerning clitic placement and tested them against the Bembe object-marking data. As a result, I concluded that an analysis à la Roberts (2010) is to be favoured. According to his account, object markers are theta-role bearing, defective pronouns – i.e.  $\phi$ Ps, which are externally merged in verb-complement position and the syntactic structure of which enables them to incorporate into their probe. Their lack of a D-layer as well as semantic content (a root) is what allows them to incorporate into the verb, as opposed to strong pronouns and lexical objects which cannot incorporate because their feature-sets are not proper subsets of that of the probe (either because the probe lacks the corresponding unvalued features of some of the features of lexical DPs, such as the value of root (cf. Holmberg 2010), or because it lacks an EPP feature (cf. Roberts 2010a,b)).

However, I have also shown that a standard approach to Agree (Chomsky 2000, 2001), as adopted by Roberts (2010a,b), according to which probing proceeds downward is insufficient to adequately describe the object-marking facts in Bembe, since the principle Closest Goal alone does not guarantee that the correct goal will be chosen for the Agree relationship with  $v$ . I thus propose that Agree with  $v$  requires Full Match, and that object markers enter the derivation equipped with an interpretable [TOP]-feature, required to value the unvalued counterpart on  $v$ . This is in line with the referential, discourse-old interpretation of object markers, and serves to ensure that it is

the  $\phi$ P that agrees with and incorporates into  $v$ , satisfying the corresponding unvalued feature on  $v$ . This is sufficient to correctly derive the word order and object-marking facts in transitive, ditransitive, applicative, applied ditransitive, and subject and object relative sentences. The fact that incorporation of defective pronouns into  $v$  can be equally well explained by assuming that it is triggered by the need to value a feature suggests that despite all differences that exist pronominal and grammatical agreement, they are actually two sides of the same coin (cf. Givón 1976, Roberts 2010a,b).

Chapter 4 is devoted to the topic of subject marking in Bembe. The chapter began with an introduction to subject marking and the variation one encounters across the Bantu languages, followed by a review of the recently revived theoretical debate surrounding its grammatical nature in Bantu and other null subject languages. Subsequently I embarked on an analysis of the categorial status of subject markers in Bembe. In the latter, I sought an answer to the question whether subject markers should be treated as agreement morphology, pronouns, or as being ambiguous between the two, in the course of which I dismissed a potential analysis for Bembe under which subject markers are ambiguous between being agreement morphology and pronouns (as done for Chicheŵa by B&M 1987). Instead, I presented distributional and interpretational evidence which shows that preverbal subject DPs show topic-like properties, most importantly an obligatory wide-scope reading and a complementary distribution with subject markers (in the inflectional domain), which implies that they are always in a dislocated position. This, in turn, strongly suggests that subject markers are pronominal elements rather than grammatical agreement morphology.

As regards the structural make-up of the Bembe clause, I subsequently showed how a traditional movement analysis, according to which subject markers are pronominal elements, struggles to account for the presented Bembe facts, as it is unable to give a reason as to why pronominal subject markers can raise to a preverbal position while subject DPs have to stay low in object relative clauses. More recent grammatical-agreement analyses, in contrast, attempt to explain the perceived topic status of preverbal subjects in Bantu by postulating the presence of null subjects which are made responsible for determining agreement on verbs, such as Baker (2003, 2008) and Carstens (2005). Both analyses stress that Bantu languages defy Chomsky's latest (2000, 2001) approach to probe-goal feature valuation in that agreement seems to require a spec-head relation between probe and goal, and thus movement. In order to accommodate the Bantu facts, they modify the probe-goal approach to feature valuation. However, both Baker's (2003, 2008) and Carstens' (2005) proposals struggle to account

for the different agreement and word order patterns in Bembe, most notably in the case of Type 1 and 2 relative clauses. In fact, under Carstens' analysis, Type 1 relative clauses are entirely ruled out, contrary to facts.

Subsequently, I demonstrated that an account as presented by Henderson (2006, 2011a) who proposes the most far-reaching alteration to the feature valuation, is able to explain a variety of word order and agreement patterns across Bantu languages, in particular the variation in availability and agreement within single Bantu languages with regard to operator constructions (REL/TOP-V-S). Under Henderson's analysis, the availability of subject markers vs. preverbal subject DPs in object relative clauses is a matter of projecting a specifier of TP or not, which is parameterised between as well as within languages. Ultimately, I came to the conclusion that his predictions are not entirely born out for Bembe either, since both his analyses fail to predict attested subject-marking patterns and word orders.

I claimed that the inability of the discussed analyses to account for the variation in Bembe object relative clauses and other constructions can be found in the fact that they are flawed in their initial assumption to treat subject markers as the spell-out of an Agree relation between T and a null subject *pro*. Instead, I proposed that they should be analysed as the spell-out between T and pronominal  $\phi$ Ps, like Bembe object markers. Following Roberts' (2010) treatment of Romance object clitics, subject markers are defective clitic pronouns ( $\phi$ Ps), i.e. theta-role bearing arguments of the verb, which are base-generated in  $v$ P and which, due to their defective nature, can incorporate into the head position in T. Incorporation is taken to be a corollary of the operation Agree and follows from the fact that the features of  $\phi$ Ps form a proper subset of the features of the probe. It thus precludes the need for an active spec,TP position in Bembe. Despite being theta-role bearing arguments,  $\phi$ Ps are non-referential, and thus in need of a referential value, which is provided by a dislocated (and possibly null) A(boutness)-topic DP (Frascarelli 2007, Holmberg 2010), which additionally explains the A'-properties of preverbal subjects.

As regards the operation Agree, I maintain that downwards probing (in line with Chomsky 2000, 2001) in conjunction with the additional assumption that Agree relations between T and subject DPs are not spelled out in Bembe (since the features of these are not a proper subset of the features of T) captures the Bembe facts. This makes more drastic changes to the feature-valuation mechanism (as proposed in Baker 2003, 2008; Carstens 2005; Henderson 2006, 2011a) unnecessary. Instead, the presented set of assumptions is sufficient to derive the discussed constructions without having to resort

to a movement trigger, such as a [TOP]-feature on T. In fact, I have demonstrated that nothing occupies spec,CP in default agreement inversions either, which suggests that a comparable movement trigger on C is unnecessary too. Only in the case of relative clauses is a [REL]-feature on C present, which is responsible for raising the element to be relativised into spec,CP. However, in order to correctly predict Type 1 object relatives, a Full Match requirement has to be postulated with respect to feature valuation.

In the remaining constructions, i.e. declarative clauses and locative inversions, spec,CP is filled with a dislocated (and possibly null) A(boutness)-topic DP, which is responsible for providing  $\phi$ Ps with a referential value, since  $\phi$ Ps enter the derivation as non-referential elements (cf. Frascarelli 2007; Holmberg 2010). This additionally explains the A'-properties of preverbal subject DPs in Bembe. However, there is nothing that suggests that a traditional EPP or any other movement trigger is present in Bembe. Another unexpected but welcome result of not having to assume a [TOP]-feature on either C or T in the analysis is that this predicts the ungrammaticality of subject-object reversals, in line with the Bembe facts, which analyses we have discussed earlier would not do. Moreover, the assumption that the derivation of locative constructions and default agreement inversions involves a defective  $\phi$ P as grammatical subject and null expletive, respectively, which are merged low (within the VP) (Bowers 2002; Diercks 2012), opens up the possibility of explaining the transitivity constraints in these two constructions in the form of a ban on multiple specifiers (cf. Richards & Biberauer 2005; Richards 2007). We also saw that the assumption that something like Kinyalolo's (1991) constraint holds in Bembe is necessary to derive the attested subject marking facts in Bembe, at least in the case of declarative clauses, locative constructions and default agreement inversions.

Finally, in section 4.4, I discuss the issue of Case and the question of how Case-feature valuation takes place in the proposed analysis. Bantu languages do not show morphological case, and I presented evidence from Diercks (2012), which suggests that abstract Case is altogether absent in many Bantu languages. With respect to Bembe, evidence in the form of licensed DPs in non-licensed positions, licensed DPs in non-Case-marked positions, and the ability of DPs to move out of positions in which they have had their Case-feature valued lead me to conclude that the same is true for Bembe, and that, ultimately, *u*Case-features cannot play a part in the feature-valuation process. Instead, I follow Carstens (2010) and Carstens & Diercks (2013) who assume that a feature other than *u*Case must be responsible for the hyperactivity of Bantu verbs and

regard the Gender feature as a viable candidate. As this feature is meaningless and thus uninterpretable, it does not play any role under Agree in Bantu. Since there is nothing that renders goals inactive for further feature-valuation operations, this correctly predicts the phenomenon of hyper-agreement and the presence of DPs in non-licensed positions.

## 5.2 Questions for further research

This thesis focuses on the domain of subject and object marking and its implications for word order. It is therefore only natural that there remain many issues which have been mentioned only in passing and did not receive the proper treatment they deserve. Space limitations prevent me from discussing these in depth.

Given that the main theoretical questions in this thesis are concerned with subject and object marking, and indirectly with their effects on the availability of certain word orders, it comes as no surprise that the descriptive part in Chapter 2 focuses mainly on the morpho-syntactic and syntactic properties of the language while the phonology has received considerably less attention. At the same time it has been known for quite some time now that the phonology, or rather phonological processes play a very important role in the Bantu languages. Of special interest in this respect are tones, which are not only employed lexically but, more importantly, also to mark grammatical contrasts. One domain in Bembe in which this becomes important are relativisation contexts, where the only feature by which relative clauses can be distinguished from declarative clauses is the high tone on the last syllable (abstracting away from the difference between class 1 subject and relative markers). A more detailed inquiry into the properties of tone and the processes it drives in Bembe could not be considered in this thesis but is highly desirable. More generally, further research on phonological processes is needed in order to determine the impact phonology has in the domain of syntax, which would contribute to the ongoing development of theories of the phonology-syntax interface (cf. see Cheng & Downing 2009, 2012; Dobashi 2009, 2010; Downing 2010; Hyman & Byarushengo 1984).

In discussing verbal categories (section 2.3.2), I assumed the prefix *i-* to be a focus marker. The main reason for this assumption is the fact that in the data set they predominantly appear in cleft constructions, the function of which is to induce a narrow focus reading on the clefted element. However, as noted earlier, there are contexts, in which it is not clear to me whether the prefix in the examples in (167a-b), repeated here

as (539), exhibits the same function, as it can precede connectives (539a) and nouns (539b) alike.

- (539) a. *Eno i-computa i ya ngene.*  
 9DEM.prox ?-9computer ? 9CONN goodness  
 “This is the computer that is good.”
- b. *Bano i-baana ba-a-kol-á bilewa.*  
 2DEM.prox ?-2child 2SM-N.PST-buy-FV 8food.  
 “These are the children that have bought (some) food.”

The data on the usage of *i-* in (539) evokes the impression of dealing with a copula, in which case this could be taken to be an interesting case of grammaticalisation of a copula to focus marker. The grammaticalisation path of copula > focus marker is attested in Bantu (Heine & Kuteva 2002: 95) and synchronic examples of copulas being used as focus markers in Bantu are abundant. In Ikalanga (S16), for instance, the copula *ndi-* is also used as a focus marker (Mathangwane 1998). Moreover, Heine & Reh (1984: 162-165) have demonstrated that focus markers often develop from copulas in the context of cleft constructions and may spread to other contexts once their use is established. Givón (1990), for instance, argues that the *ni-* focus particle in Swahili goes back to an older form of the copula (but see McWhorter 1994 for arguments that it derives from an identificational demonstrative).<sup>59</sup> In the same vein, Dalgish (1979: 57-63) claims that the particle *ni* in Kivunjo-Chaga (E622C), which is used for assertion, is derived from a copula. However, since cleft constructions always involve relative clauses, there exists the possibility that what used to be a relative-clause marker has been re-analysed as focus marker (see Harris & Campbell 1995 for an example from Breton).

Cleft constructions in Bembe also remain understudied with respect to their information-structural properties. For instance, the data set contains examples of all-new Wh-questions that have been answered with a cleft construction in Bembe, as discussed in section 2.4.3 and illustrated here as (540).

---

59 McWhorter’s (1994) objection to Givón’s (1990) claim that the focus particle *ni-* derives from a demonstrative rather than a copula is not problematic in this context insofar as Heine & Kuteva (2002: 330-331) state explicitly that a demonstrative can develop into a copula and subsequently into a focus marker (cf. Byrne & Winford 1993).



(540) Q: *E-le éé?*  
 7SM-COP 7what  
 (Lit. “It is what?”)  
 “WHAT HAPPENED?”

A: *Ba-le baana ba-a-kol-á kyenga.*  
 2SM-COP 2child 2REL-N.PST-buy-PST 9fufu  
 (Lit. “It is the children who have bought fufu.”)  
 “THE CHILDREN HAVE BOUGHT FUFU.”

The possibility to answer an all-new Wh-question with a cleft constructions is suggestive of the fact that cleft constructions, besides encoding narrow focus, can also be employed for the encoding of information focus. However, empirical evidence that warrants such an assumption is only available for subjects of transitive verbs. One possible reason for this could be the restriction of transitive subjects to not be focused in-situ (i.e. in preverbal position) in Bembe. However, Wh-questions asking for objects and obliques can be answered in-situ (i.e. in postverbal position), which makes it worthwhile investigating whether Wh-object and oblique questions can also be answered by object and oblique cleft constructions. If so, this would suggest that cleft constructions are not solely used for encoding narrow focus in Bembe but also information focus in general.

In the same vein, it is necessary to determine in more general the role information structure plays in the Bembe grammar. For instance, we have seen that the notions of topic and focus play a role when it comes to subject and object marking. Their discussion, however, remained on a fairly basic level, employing the terms ‘topic’ and ‘focus’ in an extremely underspecified sense, namely as ‘given’ and ‘new information/non-referential’, respectively. That is, a referent is given (a) when the referent is known from the discourse, (b) in case the referent forms part of world knowledge, or (c) the referent is sufficiently well-described. Focused is understood in the sense of being non-referential, and hence non-topical. A more detailed inquiry into the role of information structure in driving syntactic operations would indisputably be a welcome contribution to the growing field of research concerned with the Syntax-Information Structure interface.

Each of the theoretical topics addressed in Chapters 3 and 4, in particular subject marking in relatives clauses, locative and default agreement inversion, are all in some way related to the growing tendency to treat heads in Bantu languages as probing their

c-commanding structure rather than the c-commanded one and, as a result, agreeing with some structurally higher goal. This is formulated in the so-called Upward Agreement Hypothesis (UAH; in different forms in Collins 2004; Carstens 2005; Baker 2008; Zeijlstra 2012). This stands in opposition to the view that probing under Agree is downward and thus a spec-head relation between a probe and a goal not a prerequisite for Agree (Chomsky 2000, 2001). As we have seen, the UAH and the discussed agreement approaches do not hold up under empirical scrutiny, which strongly suggests that a pronominal analysis is better suited for Bembe. While the here-presented Bembe data are far from constituting direct evidence against the universal treatment of Bantu subject marking as an agreement phenomenon, they do show that there exists an alternative analysis that retains downward probing under Agree, the predictions of which are worth testing against other (Bantu) language data.

Speaking from a more comparative perspective, it remains to be seen whether the predictions made by the presented incorporation analysis to subject and object marking are borne out in other Bantu languages (and possibly languages of other language families (cf. Holmberg 2010)). I expect that there exist other languages in which the phenomena of subject and object marking both independently lend themselves to an incorporation analysis. As regards subject marking, the similar properties of subject-marking and the word-order variation encountered in object relative clauses of the neighbouring languages Kilega (D25) and Chiluba (L31) offer a viable starting point for testing whether the subject marking could be a case of incorporation rather than simply agreement. Zulu (S42) seems to be another good candidate.

With respect to object marking, given the number of languages for which it has been established that object marking is pronominal (cf. Ch.3; section 3.1), a clitic-incorporation analysis stands a good chance of making the correct predictions with respect to object marking in other Bantu languages. The current trend of an Agree-based clitic-incorporation accounts to object marking in Bantu and other languages (all of which differ in their execution) (Roberts 2010; Nevins 2011; Kramer 2011, 2014; Bax Diercks 2012) is certainly a testament to that. Treating incorporation as an Agree-based feature-valuation process, would enable us to bridge the differences that exist between the pronoun-incorporation and agreement analyses, and it is interesting to see if and how the results of this thesis (and other incorporation analyses) fit into current attempts at parameterising object marking throughout a number of Bantu languages.

## References

- Abels, K. & P. Muriungi (2008). The Focus Marker in Kĩtharaka: Syntax and Semantics. *Lingua* 118: 678–731.
- Adams, N. (2010). The Zulu Ditransitive Verb Phrase. Ph.D.: University of Chicago.
- Ackema, P. (1999). *Issues in Morphosyntax*. Amsterdam: John Benjamins.
- Aissen, J. (2003). Differential Object Marking: Iconicity vs. Economy. *Natural Language & Linguistic Theory* 21: 435–483.
- Alexiadou, A. & E. Anagnostopoulou (1998). Parametrizing AGR: Word Order, V-Movement and EPP-Checking. *Natural Language and Linguistic Theory* 16: 491–539.
- Alexiadou, A., P. Law, A. Meinunger & C. Wilder (eds.). (2000). *The Syntax of Relative Clauses*. Amsterdam: John Benjamins.
- Anagnostopoulou, E. (2003). *The Syntax of Ditransitives: Evidence from Clitics*. Berlin: Mouton de Gruyter.
- Aoun, J. (1981). The Formal Nature of Anaphoric Relations. Ph.D.: MIT.
- Aoun, J. (1985). *A Grammar of Anaphora*. Cambridge, Mass.: MIT Press.
- Asende Pondamali, J.C. (1996). La Morphologie Dérivationnelle de la Langue Ehembe D54 – Approche Morpho-Sémantique. MA dissertation: Université de Lubumbashi.
- Ashton, E.O. (1944). *Swahili Grammar*. London: Longmans, Green & Co
- Baker, M. (1988). *Incorporation. A Theory of Grammatical Function Changing*. London: University of Chicago Press.
- Baker, M. (2003). Agreement, Dislocation, and Partial Configurationality. In: A. Carnie, H. Harley & M.A. Willie (eds.). *Formal Approaches to Function in Grammar: in Honor of Eloise Jelinek*. Amsterdam: John Benjamins. 107–132.
- Baker, M. (2008). *The Syntax of Agreement and Concord*. Cambridge: Cambridge University Press.
- Barbosa, P. (1995). Null Subjects. Ph.D.: MIT.
- Bastin, Y. (1989a). El prefijo locativo de la clase 18 y la expresión del progresivo presente en Bantu (1). *Estudios Africanos* 4, 6: 35–55.
- Bastin, Y. (1989b). El prefijo locativo de la clase 18 y la expresión del progresivo presente en Bantu (2). *Estudios Africanos* 4, 7: 61–86.

- Bax, A. & M. Diercks (2012). Information Structure Constraints on Object Marking in Manyika. *Southern African Linguistics and Applied Language Studies* 30(2): 185–202.
- Bearth, T. (2003). Syntax. In: D. Nurse & G. Philippson (eds.). *The Bantu Languages*. London: Routledge. 121–42.
- Beaudoin-Lietz, C., D. Nurse & S. Rose (2004). Pronominal Object Marking in Bantu. In: A. Akinlabi & O. Adesola (eds.). *Proceedings of the 4<sup>th</sup> World Congress of African Linguistics*. New Brunswick, 2003. Köln: Rüdiger Köppe. 175–188.
- Béjar, S. & M. Rezac (2009). Cyclic Agree. *Linguistic Inquiry* 40: 35–73.
- Belletti, A. (1988). The Case of Unaccusatives. *Linguistic Inquiry* 19(1): 1–34.
- Benedicto, E. (1997). *The Syntax and Semantics of Non-Canonical NP Positions*. Ph.D.: UMass.
- Bernd, B. & M. Reh (1984). *Grammaticalization and Reanalysis in African Languages*. Hamburg: Buske.
- Bhatt, R. (2002). The Raising Analysis of Relative Clauses: Evidence from Adjectival Modification. *Natural Language Semantics* 10: 43–90.
- Bianchi, V. (1999). *Consequences of Antisymmetry: Headed Relative Clauses*. Berlin: Mouton de Gruyter.
- Bianchi, V. (2000). The Raising Analysis of Relative Clauses: A Reply to Borsley. *Linguistic Inquiry* 31: 123–140.
- Bibilya Msahu Wangene Ebembe 'Ya Cino Suku (The Bible in Ebembe)*. (1990). Alliance Biblique Universelle. Societe Biblique du Zaire.
- Bickel, B., B. Comrie & M. Haspelmath (2004). The Leipzig Glossing Rules: Conventions for Interlinear Morpheme-by-Morpheme Glosses. [Accessible at <http://www.eva.mpg.de/lingua/resources/glossing-rules.php>; last accessed on 25/07/2014].
- Bickmore, L. (2000). Downstep and Fusion in Namwanga. *Phonology* 17: 297–333.
- Bokamba, E.G. (1976). *Question Formation in Some Bantu Languages*. Ph.D.: Indiana University, Indiana.
- Borer, H. (1984). *Parametric Syntax*. Dordrecht: Foris Publications.
- Borsley, R.D. (1997). Relative Clauses and the Theory of Phrase Structure. *Linguistic Inquiry* 28: 629–647.
- Bošković, Ž. (2001). *On the Nature of the Syntax-Phonology Interface: Cliticization and Related Phenomena*. Amsterdam: Elsevier.
- Bošković, Ž. (2002) A-Movement and the EPP. *Syntax* 5: 167–218.

- Bošković, Ž. (2011). On Unvalued Uninterpretable Features. In: Proceedings of the North East Linguistic Society 39. GLSA: University of Massachusetts, Amherst.
- Bošković, Ž. & J. Nunes. (2007). The Copy Theory of Movement: A View from PF. In: N. Corver & J. Nunes (eds.). *The Copy Theory of Movement*. Amsterdam: John Benjamins. 13–74.
- Bougou, P. (19—). Étude morphologique du Bembe. Paris : Langues et Civilisations à Tradition Orale (LACITO).
- Bowers, J. (2002). Transitivity. *Linguistic Inquiry* 33: 183–224.
- Bresnan, J. (1990). African Languages and Syntactic Theories. *Studies in the Linguistic Sciences* 20: 35–48.
- Bresnan, J. (1997). The Emergence of the Unmarked Pronoun: Chicheŵa Pronominals in Optimality Theory. Berkeley Linguistic Society 23. [Accessible at the LFG archive: <http://www-lfg.stanford.edu/archive/archive.html> / last accessed on 25/07/2014]
- Bresnan, J. (2001). The Emergence of the Unmarked Pronoun. In: G. Legendre, J. Grimshaw & S. Vikner (eds.). *Optimality-Theoretic Syntax*. Cambridge, Mass.: MIT Press. 113–142.
- Bresnan, J. & S. Mchombo (1987). Topic, Pronoun and Agreement in Chicheŵa. *Language* 63: 741–782.
- Brody, M. (1997). Mirror theory. Ms.: University College London. [Earlier short version appeared in UCL Working Papers in Linguistics 9: 179–222].
- Buell, L. (2005). Issues in Zulu Verbal Morphosyntax. Ph.D.: University of California, Los Angeles.
- Buell, L. (2006). The Zulu Conjoint/Disjoint Verb Alternation: Focus or Constituency? In: L. Downing, L. Marten & S. Zerbian (eds.). Papers in Bantu Grammar and Description. *ZAS Papers in Linguistics* 43: 9–30.
- Buell, L. (2007). Semantic and Formal Locatives: Implications for the Bantu Locative Inversion Typology. *SOAS Working Papers in Linguistics* 15: Bantu in Bloomsbury – Special Issue on Bantu Linguistics. 105–120.
- Buell, L.C. (2008). VP-internal DPs and Right Dislocation in Zulu. *Linguistics in the Netherlands* 37–49.
- Burzio, L. (1986). *Italian Syntax*. Dordrecht: D. Reidel Publishing Company.
- Byarushengo, E.R., L.M. Hyman & S. Tenenbaum (1976). Tone, Accent and Assertion in Haya. In: L.M. Hyman (ed.). *Studies in Bantu Tonology*. University of Southern California, Los Angeles. 183–205.

- Bybee, J. L., R. Perkins & W. Pagliuca. (1994). *The Evolution of Grammar: Tense, Aspect and Modality in the Languages of the World*. Chicago: The University of Chicago Press.
- Byrne, F. & D. Winford (eds). (1993). *Focus and Grammatical Relations in Creole Languages*. Amsterdam: John Benjamins.
- Cardinaletti, A. & M. Starke (1999). The Typology of Structural Deficiency: A Case Study of the three Classes of Pronouns. In: H. van Riemsdijk (ed.). *Clitics in the Languages of Europe*. Berlin: Mouton de Gruyter. 145–233.
- Carstens, V. (2001). Multiple Agreement and Case Deletion: Against phi-(In)completeness. *Syntax* 4:147–163.
- Carstens, V. (2005). Agree and EPP in Bantu. *Natural Language & Linguistic Theory* 23: 219–279.
- Carstens, V. (2010). Implications of Grammatical Gender for the Theory of Uninterpretable Features. In: M. Putnam (ed.). *Exploring Crash Proof Grammars*. Amsterdam: John Benjamins. 31–57.
- Carstens, V. (2011). Hyperagreement and Hyperactivity in Bantu. *Lingua* 121(5): 721–741.
- Carstens, V. (2012). Delayed Valuation. [Accessible at [ling.auf.net/lingbuzz/001432/v9.pdf](http://ling.auf.net/lingbuzz/001432/v9.pdf) / last accessed on 25/07/2014]
- Carstens, V. & K.K. Kinyalolo (1989). On IP Structure: Tense, Aspect and Agreement. Ms.: Cornell University and UCLA.
- Carstens, V. & M. Diercks (2013). Parameterizing Case and Activity: Hyper-raising in Bantu. In: S. Kan, C. Moore-Cantwell & R. Staubs (eds.). *Proceedings of the 40<sup>th</sup> Annual Meeting of the North East Linguistic Society*. Amherst: University of Massachusetts Graduate Linguistic Student Association. 99–118.
- Carstens, V. & L. Mletshe (Forthcoming). Radical Defectivity: Implications of Xhosa Expletive Constructions for Bantu Case and Flavors of T and v\*. University of Missouri & University of the Western Cape. [Accessible at <http://ling.auf.net/lingbuzz/001750/v2.pdf> / last accessed on 25/07/2014].
- Cheng, L. L. & Laura J. Downing (2009). Where's the topic in Zulu? In: H. de Hoop & G. van Bergen (eds.). Special Issue on Topics Cross-linguistically. *The Linguistic Review* 26: 207–238.
- Cheng, L. L. & L. J. Downing (2012). Prosodic Domains do not Match Spell Out Domains. *Phonology in the 21st Century: In Honour of Glyne Piggott*. *McGill Working Papers in Linguistics* 22: 1. [Accessible at

<http://www.mcgill.ca/mcgwpl/files/mcgwpl/chengdowning2012.pdf> / last accessed on 25/07/2014]

- Chomsky, N. (1957). *Syntactic Structures*. The Hague: Mouton.
- Chomsky, N. (1965). *Aspects of the Theory of Syntax*. Cambridge: M.I.T. Press.
- Chomsky, N. (1973). *Conditions on Transformations*. In: S.R. Anderson & P. Kiparsky (eds.). *A Festschrift for Morris Halle*. New York: Holt, Rinehart and Winston.
- Chomsky, N. (1977). On Wh-Movement. In: P.W. Culicover, T. Wasow & A. Akmajian (eds.). *Formal Syntax*. New York: Academic Press. 71–132.
- Chomsky, N. (1981). *Lectures on Government and Binding*. Dordrecht: Foris.
- Chomsky, N. (1986). *Barriers*. Cambridge, Mass.: MIT Press.
- Chomsky, N. (1993). A Minimalist Program for Linguistic Theory. In: K. Hale & S.J. Keyser (eds.). *The View from Building 20: Essays in Linguistics in Honor of Sylvain Bromberger*. Cambridge, Mass.: MIT Press. 1–52.
- Chomsky, N. (1995). *The Minimalist Program*. Cambridge: MIT Press.
- Chomsky, N. (2000). Minimalist Inquiries: The Framework. In: R. Martin, D. Michaels & J. Uriagereka (eds.). *Step by Step: Essays on Minimalist Syntax in Honor of Howard Lasnik*. Cambridge, Mass.: MIT Press. 89–155.
- Chomsky, N. (2001). Derivation by Phase. In: M. Kenstowicz (ed.). *Ken Hale: A Life in Language*. Cambridge, Mass.: The MIT Press. 1–52.
- Chomsky, N. (2005). Three Factors in Language Design. *Linguistic Inquiry* 36(1): 1–22.
- Chomsky, N. (2004). Beyond Explanatory Adequacy. In: A. Belletti (ed.). *Structure and Beyond. The Cartography of Syntactic Structure*. Vol.3. Oxford: Oxford University Press. 104–131.
- Chomsky, N. (2007). Approaching UG from Below. In: U. Sauerland & H-M. Gärtner (eds.). *Interfaces + Recursion = Language?* New York: Mouton de Gruyter. 1–29.
- Chomsky, N. (2008). On Phases. In: R. Freidin, C.P. Otero; M.L. Zubizarreta (eds.). *Foundational Issues in Linguistic Theory. Essays in Honor of Jean-Roger Vergnaud*. Cambridge, Mass.: MIT Press. 133–166.
- Cinque, G. (1990). *Types of A'-dependencies*. Cambridge, Mass.: MIT Press.
- Cinque, G. (1999) *Adverbs and Functional Heads. A Cross-linguistic Perspective*. Oxford: Oxford University Press.

- Clements, G. N. & J. Goldsmith (1984). Introduction. In: Clements, G. N. & J. Goldsmith (eds.). *Autosegmental Studies in Bantu Tone*. Dordrecht: Foris Publications. 1–17.
- Collins, C. (2004). The Agreement Parameter. In: A. Breitbarth & H. van Riemsdijk (eds.). *Triggers*. Berlin: Mouton de Gruyter. 115–136.
- Comrie, B. (1976). *Aspect*. Cambridge: Cambridge University Press.
- Corbett, G.G. (2001). *Gender*. Cambridge: Cambridge University Press.
- Creissels, D. (2001). A Typology of Subject Marker and Object Marker Systems in African Languages. *International Symposium: Typology of African Languages*. May 21-24, Cologne.
- Dalglish, G. M. (1979). The Syntax and Semantics of the Morpheme *ni* in Kivunjo (Chaga). *Studies in African Linguistics* 10(1): 47–64.
- Dalrymple, M. & I. Nikoleva (2011). *Objects and Information Structure*. Cambridge: Cambridge University Press.
- De Cat, C. & K. Demuth (2008). *The Bantu–Romance Connection: A Comparative Investigation of Verbal Agreement, DPs and Information Structure*. Amsterdam: John Benjamins.
- Déchaine, R.-M. & M. Wiltschko (2002). Decomposing Pronouns. *Linguistic Inquiry* 33(3): 409–442.
- Demuth, K. (1990). Locatives, Impersonals and Expletives in Sesotho. *The Linguistic Review* 7: 233–249.
- Demuth, K. & C. Harford (1999a). Prosody Outranks Syntax: An Optimality Approach to Subject Inversion in Bantu Relatives. *Linguistic Analysis* 29(1–2).
- Demuth, K. & Harford, C. (1999b). Verb raising and Subject Inversion in Bantu Relatives. *Journal of African Languages and Linguistics* 20: 41–61.
- Demuth, K. & M. Johnson (1989). Interactions between Discourse Function and Agreement in Setawana. *Journal of African Languages and Linguistics* 11: 21–35.
- den Besten, H. (1985). The Ergative Hypothesis and Free Word Order in Dutch and German. In: J. Toman (ed.). *Studies in German Grammar*. Dordrecht: Foris. 23–65.
- den Besten, H. & G. Webelhuth (1987). Adjunction and Remnant Topicalization in the Germanic SOY-Languages. Paper presented at GLOW (Venice).
- den Besten, H. & G. Webelhuth (1990). Stranding. In: G. Grewendorf & W. Sternefeld. *Scrambling and Barriers*. Amsterdam: John Benjamins. 77–92.



- Diercks, M. (2008). Challenges to Case Theory from Bantu. Ms.: Georgetown University.
- Diercks, M. (2012). Parameterizing Case: Evidence from Bantu. *Syntax* 15(3): 253–286.
- Diesing, M. (1992). *Indefinites*. Cambridge, Mass.: MIT Press.
- Dobashi, Y. (2009). Multiple spell-out, Assembly Problem, and Syntax-Phonology Mapping. In: J. Grijzenhout & B. Kabak (eds.). *Phonological Domains: Universals and Deviations*. Berlin: Mouton de Gruyter. 195–220.
- Dobashi, Y. (2010). Computational Efficiency in the Syntax-Phonology Interface. *Special issue on Mapping Asymmetries: Phonology, Syntax and Information Structure. The Linguistics Review* 27(3): 241–260.
- Dobrovie-Sorin, C. (1990). Clitic Doubling, Wh-Movement, and Quantification in Romanian. *Linguistic Inquiry* 21: 351–397.
- Doke, C.M. (1931). *Textbook of Zulu grammar*. 2<sup>nd</sup> ed. Johannesburg: Witwatersrand University Press.
- Downing, L. J. (2010). An Edge-Based Approach to the Alignment of Syntactic Phases and Prosodic Phrases. In: N. Vincent & L. Mycock (eds.). Special issue: *The Prosody-Syntax Connection. Transactions of the Philological Society* 108(3): 352–369.
- Duranti, A. & E.R. Byarushengo (1977). On the Notion of “Direct Object”. In: E.R. Byarushengo, A. Duranti & L. M. Hyman (eds.). *Haya Grammatical Structure*. Los Angeles: University of Southern California. 45–71.
- Enç, M. (1991). The Semantics of Specificity. *Linguistics Inquiry* 22(1): 1–25.
- Epstein, S., H. Kitahara & T. Seely (2008). Derivation(s). In: C. Boeckx (ed.). *Handbook of Minimalist Linguistics*. Oxford: Oxford University Press. 295–310.
- Ferch, E. (2009). The Scope of Negation in Shona. Ms.: University of British Columbia.
- Frascarelli, M. (2007). Subjects, Topics and the Interpretation of Referential *pro*. An Interface Approach to the Linking of (Null) Pronouns. *Natural Language and Linguistic Theory* 25: 691–734.
- Giorgio, A. & F. Pianesi (1997). *Tense and Aspect. From Semantics to Morphosyntax*. Oxford: Oxford University Press.
- Givón, T. (1976). Topic, Pronoun, and Grammatical Agreement. In: C. Li. (ed.). *Subject and Topic*. New York: Academic Press. 149–188.
- Givón, T. (1978). Definiteness and Referentiality. In: J.H. Greenberg (ed.). *Universals of Human Language*. 291–330.
- Givón, T. (1979). *On Understanding Grammar*. New York: Academic Press.

- Givón, T. (1990). *Syntax: A Functional-Typological Introduction*. Vol. 2. Amsterdam: Benjamins.
- Givón, T. (2001). *Syntax*. Vol. 1. Philadelphia: John Benjamins.
- Gundel, J., N. Hedberg & R. Zacharski (1993). Cognitive Status and the Form of Referring Expressions in Discourse. *Language* 69: 274–307.
- Guthrie, M. (1967-71). *Comparative Bantu: An Introduction to Comparative Linguistics and Prehistory of the Bantu Languages*. 4 vols. Farnborough: Gregg International Publishers.
- Halpert, C. (2013). Structural Case and the Nature of vP in Zulu. Proceedings of NELS42. Amherst, Mass.: GLSA.
- Harizanov, B. (2011). The Syntax and Morphophonology of Object Clitics in Bulgarian. Ms.: UC Santa Cruz.
- Harjula, L. (2004). *The Ha Language of Tanzania: Grammar, Text and Vocabulary*. Köln: Rüdiger Köppe Verlag.
- Harris, C.A. & L. Campbell (1995). *Historical Syntax in Cross-Linguistic Perspective*. Cambridge: Cambridge University Press.
- Hawkins, J. (1978). *Definiteness and Indefiniteness: A Study in Reference and Grammaticality Prediction*. London: Croom Helm.
- Heine, B. & T. Kuteva (2002). *World Lexicon of Grammaticalization*. Cambridge: Cambridge University Press.
- Henderson, B. (2006a). Multiple Agreement and Inversion in Bantu. *Syntax* 9: 275–289.
- Henderson, B. (2006b). The Syntax and Typology of Bantu Relative Clauses. Ph.D.: University of Illinois at Urbana-Champaign.
- Henderson, B. (2011a). Agreement, Locality, and OVS Clauses in Bantu. *Lingua* 121, 5, 742–753.
- Henderson, B. (2011b). African Languages and Syntactic Theory: Impacts and Directions. In: E. G. Bokamba et al. (eds.). *Selected Proceedings of the 40th Annual Conference on African Linguistics*. Somerville, MA: Cascadilla Proceedings Project. 15–25.
- Herbert, R.K. (1977). Phonetic Analysis in Phonological Description: Prenasalized Consonants and Meinhof's Rule. *Lingua* 43: 339–373.
- Höhle, T. (1988). Vorwort und Nachwort zu "VERUM-Fokus." *Sprache und Pragmatik* 5, Lund University. 1–7.

- Holmberg, A. (2005). Is there a little pro? Evidence from Finnish. *Linguistic Inquiry* 36(4): 533–564.
- Holmberg A. (2010). The Null Generic Subject Pronoun in Finnish: A Case of Incorporation in T. In: T. Biberauer, A. Holmberg, I. Roberts & M. Sheehan (eds.). *Parametric Variation: Null subjects in Minimalist Theory*. Cambridge: Cambridge University Press. 200–230.
- Hualde, J. (1989). Double Object Constructions in Kirimi. In: P. Newman & R. Botne (eds.). *Current Approaches to African Linguistics* 5. Dordrecht: Foris. 179–189.
- Hurtado, A. (1985). On the Properties of LF. *Cornell Working Papers in Linguistics* 5: 121–149.
- Hyman, L.M. (2002). Suffix ordering in Bantu: A Morpho-centric Approach. In: G. E. Booij (ed.). *Yearbook of Morphology 2002*. London: Kluwer. 245–282.
- Hyman, L.M. (2007). Niger-Congo Verb Extensions: Overview and Discussion. In: D.L. Payne & J. Peña (eds.). *Selected Proceedings of the 37th Annual Conference on African Linguistics*. Sommerville, Mass.: Cascadilla Proceedings Project. 149–163.
- Hyman, L.M. & E.R. Byarushengo (1984). A model of Haya Tonology. In: G.N. Clements & J. Goldsmith (eds.). *Auto-segmental Studies in Bantu Tone*. 53–103.
- Hyman, L.M. & A. Ngunga (1994). On the Non-Universality of Tonal Association Conventions: Evidence from Ciyao. *Phonology* 11: 25–68.
- Jaeggli, O. (1982). *Topics in Romance Syntax*. Dordrecht: Foris.
- Jaeggli, O. (1986). Three Issues in the Theory of Clitics: Case, Doubled NPs and Extraction. In: H. Borer (ed.). *The Syntax of Pronominal Clitics*. New York: Academic Press. 15–42.
- Julien, M. (2002). *Syntactic Heads and Word Formation*. Oxford: Oxford University Press.
- Kayne, R. (1975). *French Syntax: the Transformational Cycle*. Cambridge, Mass.: MIT Press.
- Kayne, R. (1994). *The Antisymmetry of Syntax*. Cambridge, Mass.: MIT Press.
- Kayne, R. & J.Y. Pollock (2001). New Thoughts on Stylistic Inversion. In: A. Hulk & J.Y. Pollock (eds.). *Subject Inversion in Romance and the Theory of Universal Grammar*. Oxford: Oxford University Press.
- Kimenyi, A. (1980). *A Relational Grammar of Kinyarwanda*. Berkeley, Calif.: University of California Press.

- Kinyalolo, K.K. (1991). Syntactic Dependencies and the Spec-Head Agreement Hypothesis in KiLega. Ph.D.: University of California at Los Angeles.
- Kinyalolo, K.K. (2003). Limiting the scope of V-movement in KiLega (D25). Presented at Niger-Congo workshop, Rutgers University, March 14.
- Kisseberth, C. (1984). Digo Tonology. In: Clements, G. N. & J. Goldsmith. *Autosegmental Studies in Bantu Tone*. Dordrecht: Foris Publications. 105–182.
- Kisseberth, C. & D. Odden (2003). Tone. In Nurse, D. & G. Philippson (eds.) *The Bantu Languages*. London: Routledge. 59–70.
- Koopman, H. (2000). *The Syntax of Specifiers and Heads*. London: Routledge.
- Koopman, H. & D. Sportiche (1991). The Position of Subjects. *Lingua* 85(1): 211–258.
- Koopman, H. & A. Szabolcsi (2000). *Verbal Complexes*. Cambridge, Mass.: MIT Press.
- Kramer, R. (2011). Clitic doubling or Object Agreement: An Amharic investigation. Ms.: Georgetown University.
- Kramer, R. (2014). Clitic doubling or Object Agreement: The View from Amharic. *Natural Language and Linguistic Theory* 32: 593–634.
- Laka, I. (1994) *On the Syntax of Negation*. London: Garland.
- Lambrecht, K. (2001). A Framework for the Analysis of Cleft Constructions. *Linguistics* 39: 463–516.
- Larson, R. K. (1988). On the Double Object Construction. *Linguistic Inquiry* 19: 381–405.
- Lechner, W. (2005). Interpretive Effects of Head Movement. Ms.: University of Tübingen.
- Lethsolo, R. (2002). Syntactic Domains in Ikalanga. Ph.D.: University of Michigan.
- Lewis, M. P. & G.F. Simons (2010). Assessing Endangerment: Expanding Fishman’s GIDS. *Revue Roumaine de Linguistique* 55(2): 103–120. [Accessible at [http://www.lingv.ro/resources/scm\\_images/RRL-02-2010-Lewis.pdf](http://www.lingv.ro/resources/scm_images/RRL-02-2010-Lewis.pdf) / last accessed on 25/07/2014].
- Lewis, M. P., G. F. Simons & C.D. Fennig (2014). (eds.). *Ethnologue: Languages of the World*. 17<sup>th</sup> edition. Dallas, Texas: SIL International. [Accessible at <http://www.ethnologue.com> / last accessed on 25/07/2014].
- Lodhi, A.Y. (2002). Verbal extensions in Bantu. (The Case of Swahili and Nyamwezi). *Africa & Asia* 2: 4–26.
- Mahajan, A. (2000). Eliminating Head-movement. *Glow Newsletter* 44: 44–45.
- Mahajan, A. (2003). Word Order and (Remnant) VP Movement. In: S. Karimi (ed.). *Word order and Scrambling*. Oxford: Blackwell. 217–237.

- Maho, J. F. (2009). The New Updated Guthrie List. Forthcoming. [Accessible at <http://goto.glocalnet.net/mahopapers/nuglonline.pdf> / last accessed on 25/07/2014].
- Marlo, M.R. (2008). Flexible Stems in Bantu. Ms.: Indiana University.
- Marlo, M. R. (2013). On the number of object markers in Bantu languages. Ms.: University of Missouri.
- Marten, L. (2006). Locative Inversion in Otjiherero: More on Morpho-syntactic Variation in Bantu. In: L. Downing, L. Marten & Sabine Zerbian (eds.). *Papers in Bantu Grammar. ZAS Papers in Linguistics* 43: 97–122.
- Marten, L. & N.C. Kula (2007). Morphosyntactic Co-Variation in Bantu: Two Sase Studies. *SOAS Working Papers in Linguistics* 15: 227–238.
- Marten, L., N.C. Kula & N. Thwala (2007). Parameters of Morphosyntactic Variation in Bantu. *Transactions of the Philological Society* 105(3): 253–338.
- Marten, L. & N.C. Kula (2012). Object Marking and Morpho-Syntactic Variation in Bantu. *Southern African Linguistics and Applied Language Studies* 30(2): 237–253.
- Marten, L. & J. van der Wal (Forthcoming). A Typology of Bantu Subject Inversion. *Linguistic Variation*.
- Mathangwane, J.T. (1998). Allomorphy and the Morphology-Syntax Distinction in Ikalanga. In: I. Maddieson & T.J. Hinnebusch (eds.). *Language History and Linguistic Description in Africa*. Trenton: Africa World Press. 217–228.
- Matushansky, O. (2001). Invitation to a Beheading. Handout of talk presented at LingLunch, 6 December 2001, MIT.
- Maxwell, E.M. (1981). Question Strategies and Hierarchies of Grammatical Relations in Kinyarwanda. In: *Proceedings of the 7th Annual Meeting of the Berkeley Linguistics Society*, University of California. 166–177.
- Mchombo, S. (1993). On the Binding of the Reflexive and the Reciprocal in Chicheŵa. In: S. Mchombo (ed.). *Theoretical Aspects of Bantu Grammar*. Stanford, Calif.: Center for the Study of Language and Information Publications. 181–207.
- Mchombo, S. (1998) Chichewa (Bantu). In: A. Spencer & A. Zwicky (ed.). *Handbook of Morphology*. Oxford: Blackwell. 500–520.
- Mchombo, S. (2002). Affixes, Clitics and Bantu Morphosyntax. In: M. Amberber Mengistu & P. Collins (eds.). *Language Universals and Variation*. Westport, Conn.: Greenwood Press. 182–213.

- Mchombo, S. (2004). *The Syntax of Chichewa*. Cambridge: Cambridge University Press.
- McWhorter, J. (1994). From Focus Marker to Copula in Swahili. *Berkeley Linguistics Society* 20S: 57–66.
- Meeussen, A.E. (1951). Notes Bembe, non-publié (Unpublished Notes Bembe). Musée Royal du Congo Belge (MRCB): Tervuren.
- Meeussen, A.E. (1965). A preliminary Tonal Analysis of Ganda Verb Forms. *Journal of African Languages* 4: 108–113.
- Meeussen, A. E. (1967). Bantu grammatical reconstructions. *Africana Linguistica* 3: 79–121.
- Miyagawa, S. (2010). *Why Agree? Why Move? Unifying Agreement-Based and Discourse Configurational Languages*. Cambridge, Mass.: MIT Press.
- Morimoto, Y. (2002). Prominence Mismatches and Differential Object Marking in Bantu. In: M. Butt and T. H. King (eds.). *Proceedings of the LFG02 Conference*, CSLI, Stanford.
- Müller, G. (2001). Order Preservation, Parallel Movement, and the Emergence of the Unmarked. In: G. Legendre, J. Grimshaw & S. Vikner (eds.). *Optimality-Theoretic Syntax*. Cambridge Mass: The MIT Press. 279–313.
- Mulengwa, I. (2010). The Syntax of Verb Morphology in Ebembe. MA dissertation: University of Newcastle upon Tyne.
- Muriungi, P. (2005). Wh-questions in Kitharaka. *Studies in African Linguistics* 34:43–104.
- Mutaka, N. (1994). *The Lexical Tonology of Kinande*. Munich: LINCOM EUROPA.
- Mutombo Huta, D. (1973). Ebauches de Grammaire de la Langue Bembe et du Dialecte Kalamba:yi de la Langue Luba-Kasayi. MA dissertation: Université libre de Bruxelles.
- Myers, S. (1987). Tone and the Structure of Words in Shona. Ph.D: University of Massachusetts-Amherst.
- Myers, S. (1988). AUX in Bantu Morphology and Phonology. In: Hyman, L. M. & C. Kisseberth (eds.). *Theoretical Aspects of Bantu Tone*. Stanford: CSLI Publications. 231–264.
- Myers, S. (1990). *Tone and the Structure of Words in Shona*. New York: Garland.
- Nash, Jay A. (1992). Aspects of Ruwund Grammar. Ph.D.: University of Illinois at Urbana-Champaign.
- Ndayiragije, J. (1999). Checking Economy. *Linguistic Inquiry* 30: 399–444.

- Nevins, A. (2011). Multiple Agree with Clitics: Person Complementarity vs. Omnivorous Number. *Natural Language & Linguistic Theory* 29(4): 939–971.
- Ngonyani, D. (1996). VP Ellipsis in Swahili and Ndendeule Applicatives. In: E. Garrett & F. Lee (eds.). *Syntax at Sunset: UCLA Working Papers in Syntax and Semantics* 1: 109–128.
- Nilsen, Ø. (2003). Eliminating Positions: Syntax and Semantics of Sentential Modification. Ph.D.: Utrecht University.
- Nurse, D. & G. Philippson (eds.) (2003). *The Bantu Languages*. London: Routledge. 121–42.
- Nurse, D. (2008). *Tense and Aspect in Bantu*. Oxford: Oxford University Press.
- Odden, D. (1987). Predicting Tone in Kikuria. In: D. Odden (ed.). *Current Approaches to African Linguistics*. 311–326.
- Odden, D. (1998). Principles of Tone Assignment in Tanzanian Yao. In: Hyman, L. M. & C. Kisseberth (eds.). *Theoretical Aspects of Bantu Tonology*. Stanford: CSLI. 265–314.
- Ouhalla, J. (1988). The Syntax of Head Movement: A Study of Berber. Ph.D.: University of London.
- Payne, T. (1997). *Describing Morpho-Syntax: A Guide for Field Linguists*. Cambridge: Cambridge University Press.
- Philippaki-Warbuton, I. (1977). Modern Greek Clitic Pronouns and the ‘Surface Structure Constraints’. *Journal of Linguistics* 13: 259–281.
- Philippaki-Warbuton, I. (1987). The Theory of Empty Categories and the pro-Drop Parameter in Modern Greek. *Journal of Linguistics* 23: 289–318.
- Pinto, M. (1997). Licensing and Interpretation of Inverted Subjects in Italian. Ph.D.: Utrechts Instituut voor Linguïstiek (UiL OTS).
- Pollock, J.-Y. (1983). Sur Quelques Propriétés Des Phrases Copulatives En Français. *Langue Française* 58: 89–125.
- Pollock, J.-Y. (1989). Verb movement, Universal Grammar, and the Structure of IP. *Linguistic Inquiry* 20: 365–424.
- Pollock, J.-Y. (2006) Subject Clitics and Complex Inversion. In: M. Everaert & H. van Riemsdijk (eds.). *The Blackwell Companion to Syntax, Vol. 4*. Oxford: Blackwell. 601–659.
- Poulos, G. (1982). Issues in Zulu Relativization. Ph.D.: Rhodes University, Grahamstown, South Africa.
- Pylkkänen, L. (2002). Introducing Arguments. Ph.D.: MIT.

- Pykkänen, L. (2008). *Introducing Arguments*. Cambridge, Mass.: MIT Press.
- Reinhart, T. (1995). *Interface Strategies*. *OTS Working Papers in Linguistics*, Utrecht University.
- Reinhart, T. (2006). *Interface Strategies: Optimal and Costly Computations*. Cambridge, Mass.: MIT Press.
- Richards, M. (2007). On Object Shift, Phases and Transitive Expletive Constructions in Germanic. In: P. Pica & C. Tortora (eds.). *Linguistic Variation Yearbook 6*. Amsterdam: John Benjamins. 139–159.
- Richards, M. & T. Biberauer (2005). Explaining Expl. In: M. den Dikken (ed.). *The Function of Function Words and Functional Categories*. Amsterdam: John Benjamins. 115–153.
- Riedel, K. (2009). The Syntax of Object Marking in Sambia. Ph.D.: Leiden University.
- Rizzi, L. (1986). Null Objects in Italian and the Theory of pro. *Linguistic Inquiry* 17: 501–557.
- Rizzi, L. (1997). The Fine Structure of the Left Periphery. In: L. Haegeman (ed.). *Elements of Grammar*. Dordrecht: Kluwer. 281–337.
- Roberts, I. (1991). Excorporation and Minimality. *Linguistic Inquiry* 22: 209–218.
- Roberts, I. (1993). *Verbs and Diachronic Syntax: A Comparative History of English and French*. Dordrecht: Kluwer.
- Roberts, I. (1994). Two Types of Head Movement in Romance. In: N. Hornstein & D. Lightfoot (eds.). *Verb Movement*. Cambridge: Cambridge University Press. 207–242.
- Roberts, I. (2001). Head Movement. In: M. Baltin & C. Collins (eds.). *Handbook of Contemporary Syntactic Theory*. Oxford: Blackwell. 113–147.
- Roberts, I. (2010a). A Deletion Analysis of Null Subjects. In: T. Biberauer, A. Holmberg, I. Roberts & M. Sheehan. *Parametric Variation: Null subjects in Minimalist Theory*. Cambridge: Cambridge University Press. 58–87.
- Roberts, I. (2010b). *Agreement and Head Movement. Clitics, Incorporation, and Defective Goals*. Cambridge, Mass.: MIT press.
- Sabel, J. & J. Zeller (2006). Wh-Question Formation in Nguni. In: John Mugane et al. (eds.). *Selected Proceedings of the 35th Annual Conference on African Linguistics in Somerville, Mass.: Cascadilla Proceedings Project*. 271–283.
- Salzmann, M. (2006). *Resumptive Prolepsis - A Study in Indirect A'-dependencies*. MA dissertation: University of Leiden.
- Schachter, P. (1973). Focus and Relativization. *Language* 49: 19–46.



- Schneider-Zioga, P. (2000). Anti-Agreement and the Fine Structure of the Left Periphery. University of California: Irvine Working Papers in Linguistics 6.
- Schneider-Zioga, P. (2007). Anti-Agreement, Anti-Locality and Minimality: The Syntax of Dislocated Subjects. *Natural Language and Linguistic Theory* 25: 403–446.
- Sheehan, M. (2010). ‘Free’ inversion in Romance and the Null Subject Parameter. In: T. Biberauer, A. Holmberg, I. Roberts, & M. Sheehan (eds.). *Parametric Variation: Null Subjects in Minimalist Theory*. Cambridge: Cambridge University Press. 231–262.
- Siewierska, A. (1999). From Anaphoric Pronoun to Grammatical Agreement Marker: Why Objects Don’t Make It. *Folia Linguistica* 33(2): 225–251.
- Sportiche, D. (1992/1996). Clitic Constructions. Ms.: UCLA / In: J. Rooryck & L. Zaring (eds.). *Phrase Structure and the Lexicon*. Dordrecht: Kluwer. 213–276.
- Sportiche, D. (1998). *Partitions and Atoms of Clause Structure: Subjects, Agreement, Case and Clitics*. London: Routledge.
- Sportiche, D. (1999). Subject Clitics in French and Romance, Complex Inversion and Clitic Doubling. In: K. Johnson & I. Roberts (eds.). *Beyond Principles and Parameters: Essays in Memory of Osvaldo Jaeggli*. Dordrecht: Kluwer. 189–222.
- Suñer, M. (1988). Agreement in Clitic-Doubled Constructions. *Natural Language and Linguistic Theory* 6: 391–434.
- Svenonius, P. (1994). C-selection as Feature Checking. *Studia Linguistica* 48: 133–155.
- Tenenbaum, S. (1977). Left- and Right- Dislocations. In: E.R. Byarushengo, A. Duranti & L. Hyman (eds.). *Haya Grammatical Structure*. Los Angeles: University of Southern California. 161–170.
- Thiersch, C. (1985). VP and Scrambling in the German Mittelfeld. Ms.: University of Tilburg.
- Torrego, Esther (1988). A DP Analysis of Spanish Nominals. Ms.: University of Massachusetts.
- Toyoshima, Takashi (2000). Heading for their own Places. In: L. Veselinova, S. Robinson & L. Antieau (eds.). Proceedings of the 9th Student Conference in Linguistics (SCIL 9). *MIT Working Papers in Linguistics* 36: 93–108
- Toyoshima, Takashi (2001). Head-to-Spec Movement. In: G. M. Alexandrova & O. Arnaudova (eds.). *The Minimalist Parameter: Selected Papers from the Open Linguistics Forum*. Ottawa, 12–23 March 1997. Amsterdam: John Benjamins. 115–136.

- Travis, L. (1984). Parameters and Effects of Word Order Variation. Ph.D.: MIT
- Trask, L. (1993). *A Dictionary of Grammatical Terms in Linguistics*. London: Routledge.
- Uriagereka, J. (1988). On Government. Ph.D.: University of Connecticut.
- Uriagereka, J. (1995). Aspects of the Syntax of Clitic Placement in Western Romance. *Linguistic Inquiry* 26: 79–123.
- Van der Spuy, A. (1993). Dislocated Noun Phrases in Nguni. *Lingua* 90: 335–355.
- Van der Wal, J. (2009). Word Order and Information Structure in Makhuwa-Enahara. Ph.D.: Leiden University.
- Van der Wal, J. (2012). Subject Agreement and the EPP in Bantu Agreeing Inversion. *Cambridge Occasional Papers in Linguistics* 6: 201–236.
- Van Riemsdijk, H. C. (1999). Clitics: a State-of-the-Art Report. In: H. C. van Riemsdijk (ed.). *Clitics in the Languages of Europe*. Berlin: Mouton de Gruyter. 1–30.
- Vicente, L. (2013). On the Causes of Superiority Effects in Spanish: Preliminary Results and Prospects. *Catalan Journal of Linguistics* 12: 283–300.
- Vikner, S. (1995). *Verb Movement and Expletive Subjects in the Germanic Languages*. Oxford: Oxford University Press.
- Von Stechow, K. (2002). Specificity and Definiteness in Sentence and Discourse Structure. *Journal of Semantics* 19(3): 245–274.
- Werth, P. (1980). Articles of Association: Determiners and Context. In: J. van der Auwera (ed.). *The Semantics of Determiners*. London: Croom Helm. 250–289.
- Zanuttini, R. (1997) *Negation and Clausal Structure: A Comparative Study of Romance Languages*. Oxford: Oxford University Press.
- Zeijlstra, H. (2012). There Is Only One Way to Agree. *The Linguistic Review* 29: 491–539.
- Zeller, J. (2009). On Clitic Left Dislocation in Zulu. In: S. Ermisch (ed.). *Focus and Topic in African Languages*. Köln: Ruediger Koeppe Verlag. 131–156.
- Zeller, J. (2012). Object Marking in isiZulu. *Southern African Linguistics and Applied Language Studies* 30(2): 219–235.
- Zerbian, S. (2006). Expression of Information Structure in the Bantu Language Northern Sotho. Ph.D.: Humboldt University.
- Zwart, C. J.-W. (2001). Syntactic and Phonological Verb-Movement. *Syntax* 4: 34–6.